



### **The Rector's Greeting**

Greetings and a warm welcome to the all academic researchers, practitioners, industry and business person as well as policy makers. Thank you for attended this 4<sup>th</sup> international conference on Information Technology and Engineering Application 2015 (ICIBA 2015).

ICIBA is an annual event focusing on state of the art technologies pertaining to digital information and communications and its application in business and industry as well as government. The applications of advanced information technology to such domains as networking, security, engineering, education, finance, geosciences, health, transportation, supply chain management and logistics are among topics of relevance to ICIBA. The conference features keynote speakers, the best student award, poster award, technical open panel, and workshops/exhibits from industry, government and academia as well postgraduate student colloquium.

All papers for the ICIBA 2015 on this Conference Proceeding (ISBN) was indexed by EBSCO, Google Scholar, and sent to be reviewed by EiCompendex and ISI Proceedings. Our gratitude to all the participants who has take a part in this conference, I hope we can take the advantage of academic research findings, to have better insight about the importance of IT and business application, to the country's economic development

Sincerely yours,  
Prof. Ir. H. Bochari Rahman, M.Sc

**RECTOR of BINA DARMA UNIVERSITY**

# PROCEEDING

**INTERNATIONAL CONFERENCE ON INFORMATION  
TECHNOLOGY AND ENGINEERING APPLICATION 2015**

*IT and Engineering for Better life*

 Penerbit :  
**PPP-UBD Press**

Published by:  
Pusat Penerbitan dan Percetakan Universitas Bina Darma Press  
(PPP-UBD Press) Palembang

# **Proceeding International Conference on Information Technology and Engineering Application**

## **CONFERENCE COMMITTEE**

Muhammad Izman Herdiansyah, PhD, Universitas Bina Darma, Indonesia  
Erna Yuliwati, PhD, Universitas Bina Darma, Indonesia  
Dr. Sunda Ariana, M.Pd., M.M. Universitas Bina Darma, Indonesia  
Dr. Ahmad Syarifuddin, M.T., Universitas Bina Darma, Indonesia  
Prof. Dr. Aizaini Maarof, Universiti Teknologi Malaysia.  
Prof. Dr. Wan Nasir, Universiti Teknologi Malaysia.  
Prof Dr. Eko Indrajit, Higher Education Association Information And  
Computer Science (APTIKOM), Indonesia  
Prof Zainal A Hasibuan, PhD, Higher Education Association Information  
And Computer Science (APTIKOM), Indonesia  
Dr. Paulus Sukpto, Ir., MBA, Universitas Katolik Parahyangan, Indonesia  
Dr. Ir. T. Ari Samadhi, Institut Teknologi Bandung, Indonesia.

## **REVIEWER & EDITOR**

Leon Andreti Abdilah  
PH Saksono  
Erna Yuliwati  
M. Izman Herdiansyah  
Edi Surya Negara

Support by. Bina Darma University  
Steering Committee ICIBA  
Cover Design by. Deni Erlansyah  
Printed in Palembang, Indonesia, Febuari 2015

## CONTENTS

No	Titel	Page
<b>INFORMATION TECHNOLOGY</b>		
1.	Music Retrieval using Mood Tags in Folksonomy <b>Chang Bae Moon, HyunSoo Kim, Dong-Seong Kim, Sung-Phil Heo, Byeong Man Kim</b>	1 -6
2.	Geografic Information System for Optimization of Lane Road in Bandar Lampung Using Dijkstra Algorithm <b>Triyugo Winarko</b>	7 -12
3.	Implementation and Analysis of LCAS (Link Capacity Adjustment Scheme) Encapsulation on Ethernet Over SDH (Synchronous Digital Hierarchy) for A Reliable Network <b>Beny Nugraha, Abdaul Hidayatir Ridho</b>	13 - 18
4.	Password Designing Using Programmable Logic Device (PLD) <b>Muhammad Irmansyah, Era Madona, Nasrul</b>	19 -24
5.	Risk Management Framework in Information Technology Outsourcing Project <b>Arif Ridho Lubis, Husni Lubis, Ihsan Lubis</b>	25 - 29
6.	Systems Engineering: Why is it Important ? <b>Beni Suranto</b>	30 -37
7.	Tsukamoto Method in Decision Support System for Realization of Credit on Cooperative <b>Ginanjari Wiro Sasmito, Oman Somantri</b>	38 - 44
8.	Prediction of Understanding of Students Under Course Lecturer Professional Use Neural Network Backpropagation <b>T.Henny Febriana Harumy, Darmeli Nasution, Yuyun Yusrinda Lase</b>	45 - 52
9.	Performance Analysis of Multiple-Computer as Real Application Clusters (RAC) Based on Storage Area Network (SAN) <b>Iyoga Don Frima Tarigan, Dong-Seong Kim</b>	53 - 59



10.    IPV6 Readiness Survey: The Case of Indonesian Organizations  
        **Dedy Syamsuar, Peter Dell** 60 - 67
11.    Similarity Analysis of Audio Steganography Combined With Rijndael Cryptography Algorithm  
        **Hudson Leroy Simanjuntak, Anggoro Suryo Pramudyo, Rian Fahrizal** 68 - 72
12.    The Real Monitoring of Three Phases Power Based on Microcontroller Which Can Be Readed Online (Case Study in Laboratory of Microprocessor of Padang State Polytechnic )  
        **Anggara Nasution, Rusfandi, Era Madona** 73 - 79
13.    History of Indonesian Independence Learning Media Using Interactive Story Telling For Elementary Schools Based on Android Platform  
        **Yuliana Nyonata, T. Arie Setiawan Prasida, Birmanti Setia Utami** 80 - 86
14.    A Type-2 Fuzzy Logic for Measurement of Meta-Management Success in Virtual Organisation  
        **Muhammad Ridwan Andi Purnomo** 87 - 92
15.    Audio/Video Bridging (AVB) Protocol for Industrial Application  
        **Syamsul Rizal, Dong-Seong Kim** 93 - 97
16.    New Pheromone Updating Mechanism for Ant Colony Optimization in Designing DNA Sequence  
        **T.B.Kurniawan, Misinem, M.Z. Ahmad Nazri** 98 - 104
17.    Maximize E-Learning To Improve Students Knowledge and Interest In Learning  
        **Burham Isnanto, Bambang Adiwino, Ellya Helmud** 105 - 112
18.    Information System of Follow Up Evaluation Report Multi User Based On The Bangka Belitung Inspectorate Department  
        **Ellya Helmud, Burham Isnanto, Sujono** 113 - 118
19.    Extracting Keyword for Disambiguating Name Base on The Overlap Principle  
        **Mahyuddin K. M. Nasution** 119 - 125

- |     |   |           |
|-----|---|-----------|
| 20. | Design XML Web Services As A Data Integration Method Of<br>Between Unit Health Health Surveillance For Support Health<br>Epidemiology Data Warehousing<br><b>Slamet SN, Fikri Budiman, Sudaryanto</b> | 126 - 132 |
| 21. | Study of Wavelet Transformation Method for feature<br>Extraction Characteristics Based In Identifying Authenticity<br>Indonesian Batik<br><b>Fikri Budiman</b>  | 133 - 138 |
| 22. | Survey on Development Method of Ontology<br><b>Ria Andryani, Edi Surya Negara</b>   | 139 - 151 |

#### **ENGINEERING APPLICATION**

- |     |   |           |
|-----|---|-----------|
| 23. | Design of Portable Digester for Domestic and Restaurant<br>Organic Solid Waste Processing as Clean Biogas In Replacing<br>LPG as Alternative Energy Source<br><b>Agus Mansur, Agus Taufik, Dian Janari</b>  | 152 - 157 |
| 24. | Clustering Analysis for Tourism Research: Segmentation<br>Based On Travelers Activities<br><b>Imam Djati Widodo, Harwati, Agus Mansur</b>   | 158 - 165 |
| 25. | Design of Ergonomics Ladle Appliance<br>for Metal Casting Process<br><b>A. Hartomo Soewardi, B. Rizki Budhisaputra</b>  | 166 - 170 |
| 26. | Glass Fiber Composites and Polypropylene Construction,<br>Application for Aluminum Boat<br><b>A. Mataram, AA. Febriansyah, S. Rizal, A. Zamheri</b>   | 171 - 178 |
| 27. | Rapid Synthesis of Graphene Nanosheets and Its Structural<br>Properties Study for Direct Methanol Fuel Cell<br><b>Mohamad Fahrul Radzi Hanifah, Juhana Jaafar, Madzlan<br/>Aziz, Ahmad Fauzi Ismail</b>   | 179 - 184 |
| 28. | Antifouling Enhancement of Dual Layer Hollow Fiber<br>Membrane By Adding TiO <sub>2</sub> Nanoparticles<br><b>Mohd Hafiz Dzarfan Othman, Hanif Mossadeq, Hazlini<br/>Dzinun, Ahmad Fauzi Ismail, Mohd Hafiz Puteh,<br/>Mukhlis A. Rahman, Juhana Jaafar</b> | 185 - 192 |

29. Chemical Degradation of SPEEK/CLOISITE/TAP Membrane Under Fenton Reagent Accelerated Stress Test 193 - 198  
Muhammad Taufiq Salleh, Juhana Jaafar, Noorul Anam  
**Mohd Norddin, Ahmad Fauzi Ismail, Mohd Hafiz Dzarfan Othman, Mukhlis Abdul Rahman, Norhaniza Yusof, Wan Norharyati Wan Salleh**
30. The Characteristics Study of Titanium Dioxide Nanofibers Prepared by Electrospinning Method 199 - 204  
**Nor Azureen Mohamad Nor , Juhana Jaafar, Ahmad Fauzi Ismail, Mohd Hafiz Dzarfan Othman, Mukhlis A. Rahman, Wan Norharyati Wan Salleh, Norhaniza Yusof, Lau Woei Jye**
31. Design of Experiment (DOE) of Compressive Strength Test For Block Paving Prototype Using Thermoplastic Waste 205 - 213  
**Dian Janari**

# **INFORMATION TECHNOLOGY**

## Music Retrieval using Mood Tags in Folksonomy

Chang Bae Moon, HyunSoo Kim, Dong-Seong Kim,  
Sung-Phil Heo, Byeong Man Kim

Kumoh National Institute of Technology, Gumi, Gyeongbuk, South Korea  
e-mail: cb.moon@kumoh.ac.kr

### *Abstract*

*This paper propose a music retrieval using mood tats in folksonomy for solving Synonym problems. Normally, a music piece and a mood tag can be represented by mood numeric vectors internally. To determine the mood vectors of a music piece, 12 regressors are created by Support Vector Regression using features of a music piece. Then, a mood vector is predicted by the 12 regressors. To map a folksonomy mood tags to its mood numeric vectors, the relationship between mood vectors of music piece and the folksonomy mood tags was investigated based on tagging data retrieved from Last.fm. To evaluate retrieval performance, music pieces on Last.fm annotated with at least one mood tag were used as a test set. When calculating precision and recall, music pieces annotated with synonyms of a given query tag were treated as relevant. These experiments on a real-world data set illustrate the utility of the internal tagging of music. Our approach offers a practical solution to the problem caused by synonyms.*

**Keywords :** *Music mood, Folksonomy mood tag, Last.fm, Relationship between mood and tag*

## 1 INTRODUCTION

A folksonomy is a classification system in which volunteers collaboratively create and manage tags to annotate and categorize content. Also, the folksonomies can solve the expanding problems of taxonomies. It means, category of folksonomy can be expanded by volunteers without web manager.

However, folksonomies do tend to have problem relating to tags. The first problem is that different words can be used identical meanings by different users; for example, "relaxed and calm are different words, but a soothing piece of music may be tagged the different two words by two different users. The second problem is a tagging level; i.e., in the case of placid and very placid, the same root word is used, but those words are expressed by different degrees.

In this paper, a music retrieval method by mood tags in Folksonomy is proposed, and the method is to solve the synonyms problems when retrieving music. To do this, we introduced the mood vector (12 values representing different moods according to Thayers two-dimensional

mood model) as an internal tag. Using this method, moods of music pieces and mood tags are all represented internally by numeric values; pieces identified as having moods similar to the mood tags of a query can then be retrieved based on the similarity of their mood vectors, even if their tags do not exactly match the query.

## 2 RELATED STUDIES

Existing emotion models include the Russell model (Russell, J.A. (1980)), the Hevner Model (Hevner, K. (1936)), and the Thayer model (Thayer, R.E. (1989)). Since both the Russell and Hevner models use adjectives to describe emotions, ambiguity arises if adjectives have multiple meanings. For this reason, we used Thayers two-dimensional model, in which each mood or emotion is expressed by two values, arousal and valence. Arousal refers to the strength of stimulation that listeners feel (i.e., weak or powerful) and valence refers to the intrinsic attractiveness (positive valence) or aversiveness (negative valence).

A number of studies have explored music folksonomy tags (Steven R. Ness, et al. (2009); Laurier, C., et al. (2009); Kim, J.H., et al. (2011)). In Laurier et al.s and Kim et al.s studies (Laurier, C., et al. (2009); Kim, J.H., et al. (2011)), music mood tags from the well-known folksonomy site Last.fm were treated as categories, upon which these authors constructed classification models. These classification models first determine the category of each piece of music, and then the folksonomy tag corresponding to the category is applied. In Steven et al.s study (Steven R. Ness, et al.), music was subdivided into sub-units and features were extracted. Then, these features were learned using a Support Vector Machine (SVM). When a new music piece is inputted, a mood tag is assigned based on the classification model.

## 3 MUSIC MOOD RETRIEVAL BASED ON FOLKSONOMY TAGS

The object of the present paper is composed of four phases (Fig.1). The first and second phases are to create a prediction model for each mood; once the mood vectors of the music piece are obtained, they are attached as internal tags. The third phase is to define the mapping relationship between folksonomy tags on Last.fm and their mood vectors. The last phase is to retrieve music using mood vectors and tag-mood mapping information.

### 3.1 Creating music mood vectors and music mood prediction model

Last.fm, a prominent online example of music folksonomy in action, boasts more than 1,000 music pieces that have at least one music mood tag. These pieces can be collected using API (Application Programming Interface). However, users provide mood tags in the form of words, not in the form of a mood vector. In order to accurately translate these tags and reflect users individual intended meanings for terms with multiple possible meanings, we would need to obtain individual mood vectors from all users. However, such an approach is impractical, and would be both time-consuming and prohibitively expensive. For this reason, we built models to predict the mood vector of a given music piece using existing music mood data (Moon, C.B., et al.(2014)).

The prediction models are built through the three steps as show in Figure 1. In the analysis step of musical structure, music pieces were separated into segments through musical structural analysis (Lee, J.I., et al.(2009); Moon, C.B., et al.(2014); Levy, M., et al.(2006)). Then, three music segments were chosen for each piece by moon et al. (Moon, C.B., et

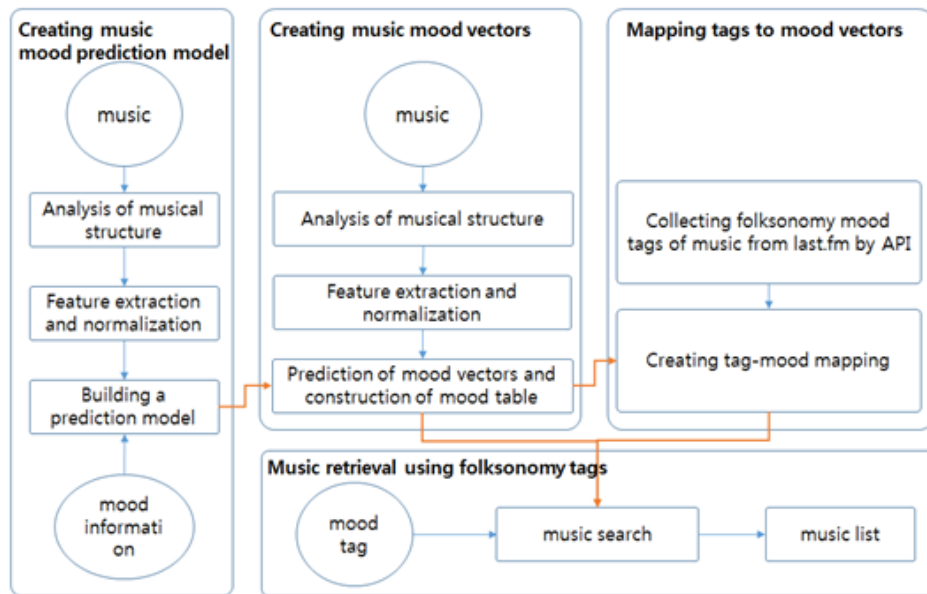

Figure 1: Overview of music retrieval system

al.(2014)): one from the Intro section, one from the Outro section, and the one with the highest energy.

In the feature extraction and normalization step, we used the 391 features extracted from Lartillots MIR toolbox (Lartillot, O., et al.(2007)). However, when features are extracted using MIR toolbox, NaN values that cannot be expressed numerically may occur. So, features with at least one NaN were removed. Thus, 330 features are used in our experiments and feature values were normalized between 1 and +1.

In the building step, we use Support Vector Regression (SVR) to build regressors. the SVR is provided by Support Vector Machines (LIBSVM) (Lee, J.I., et al.(2009); Ryu, S.-J., , et al.(2008); Chang, C.-C., et al.(2001)), which has recently become more common for regression analysis. The input value of the regressors is the normalized feature vector of a music segment, which is extracted as described above. The data from Moon et al study (Moon, C.B., et al.(2014)) were used to create predictors of mood vectors.

In predicting mood vectors of music pieces step, we used the 1,243 music pieces on Last.fm with at least one mood tag as our sample and predicted their mood vectors. Using the method described in Analysis of musical structure, three segments were selected per piece; a music vector was then created for each segment (2 or 3 per piece). The mood vector of each segment was predicted using the mood vector predictor depicted, which is henceforth referred to as a mood table of music, musicmood table, or musicmood mapping table.

### 3.2 Mapping tags to mood vectors

To obtain the mapping information for mood tags and mood vectors, we needed to collect mood tag data for all of the music pieces used in our analysis. On Last.fm, listeners can check the relevant tags of a music piece or retrieve music pieces by selecting a tag. The associated

music tags of a music piece are obtained automatically through API which requires the name of the artist and the track.

Different numbers of music pieces were associated with each tag. Therefore, we needed to define the representative mood vector of each tag. We did this by averaging the mood vectors for music pieces with the same tag. These averaged mood vectors are the mood vectors of a tag which were used to connect mood tags and music together with the musicmood table. Only 50% 70% of tag data were used to create maps; the remaining portion was used for performance evaluation.

### 3.3 Music retrieval using mood tags

The method used to retrieve music using mood tags is as follows: first, the user inputs the tag to be retrieved(query in Fig. 2); the mood vector of the query tag is then searched in the tagmood mapping table; then, music pieces with mood vectors similar to the mood vector of the query tag are retrieved.

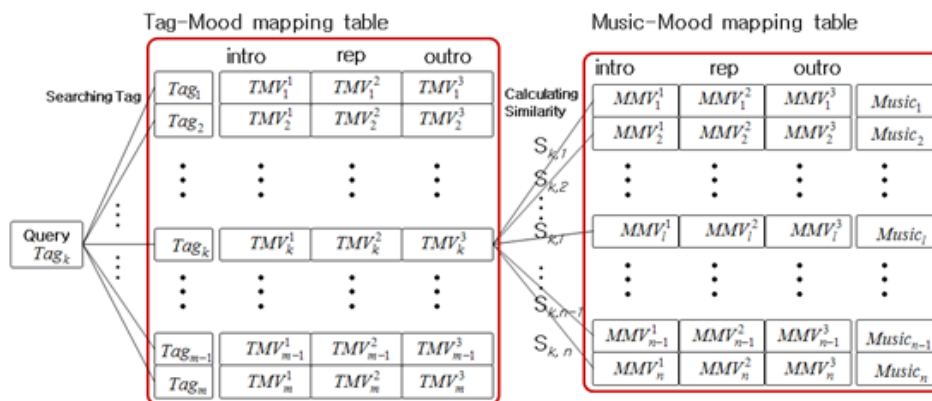

Figure 2: Music retrieval using folksonomy tags

## 4 EXPERIMENTS AND ANALYSIS

Although all mood words could be used as query tags to measure the retrieval performance of the suggested method, only the 12 words from Thayers two-dimensional mood model were considered due to the limitations on processing such a vast data set. Synonyms (provided by [www.synonym.com](http://www.synonym.com)) were used to build the answer set for the 12 mood words; For example, the tag peaceable was grouped with peaceful, as peaceable is a synonym of the basic mood adjective peaceful.” Each music piece had at least one mood tag; the number of music pieces associated with each mood are calm (501), pleased (241), sad (527), excited (304), nervous (151), peaceful (90), relaxed (527), happy (290), bored (190), sleepy (79), angry (205), and annoying (242).

The retrieval performance for the six combinations of mood vectors is given in Fig. 3 (a). The results come from using 50% of the music pieces to build the tag-mood table, and using the other 50% of the music pieces for testing. The best performance at recall level 0.1 was 0.49 for Intro, 0.59 for Representative, 0.50 for Outro, 0.54 for All, 0.51 for 3:3 MAX, and



0.56 for 1:3 MAX; Representative performed the best at most recall levels. When we changed the ratio of training: testing data from 50:50 to 70:30, the best performance was improved by 0.05 (from 0.59 to 0.64) (Fig. 3 (b)). It means, retrieval performance of our proposed method can be improved, when there are more training or testing data set.

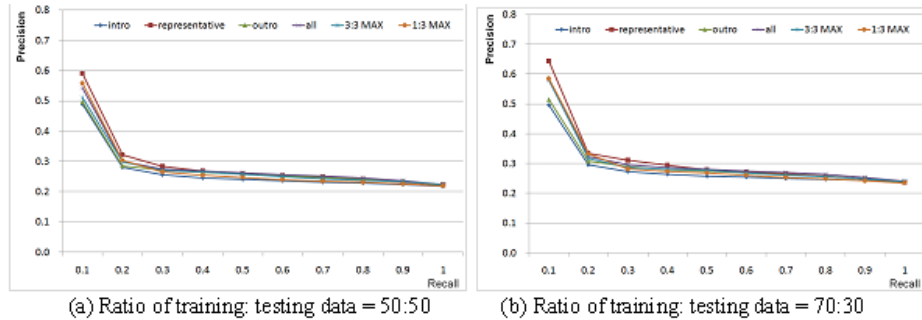

Figure 3: Retrieval performance

## 5 CONCLUSION

In this paper, to solve the synonym problem associated with folksonomies, the mood vector of music was introduced as an internal tag. A mood vector consists of 12 values indicating the presence of the 12 moods from Thayers two-dimensional mood model. Music pieces were tagged internally using these numeric values, enabling the retrieval of music with similar moods. To implement a retrieval system based on internal tags, music vectors should be generated for both music pieces and folksonomy tags.

The paper demonstrated the internal tagging of music to be useful when combined with our scheme for solving the problem caused by synonyms. However, the retrieval performance of this approach could be improved by enhancing the predictive power of mood vectors, which is largely dependent on the quality and quantity of the training data provided.

## 6 ACKNOWLEDGMENT

This research was supported by the MSIP(Ministry of Science, ICT and Future Planning), Korea, under the ITRC(Information Technology Research Center) / CITRC(Convergence Information Technology Research Center) support program (NIPA-2014-H7501-14-1002) supervised by the NIPA(National IT Industry Promotion Agency)

## References

- Chang, C.-C., Lin, C.-J. (2001), LIBSVM: a library for support vector machines. Software available at <http://www.csie.ntu.edu.tw/~cjlin/libsvm/>.
- Hevner, K. (1936), xperimental studies of the elements of expression im music. *The American Journal of Psychology*, Vol. 48, No. 2, 24668.
- Kim, J.H., Lee, S., Kim, S.M., Yoo, W.Y.(2011), Music mood classification model based on Arousal- Valence values. *In: Proc. ICACT*. pp. 292295.

- Lee, J.I., Yeo, D.-G., kim, B.M., Lee, H.-Y. (2009), Automatic Music Mood Detection through Musical Structure Analysis. *International Conference on Computer Science and its Application CSA 2009*, 510-515.
- Lartillot, O. and Toiviainen, P.(2007), A Matlab toolbox for musical feature extraction from audio. *Proc. of the 10th Int. Conference on Digital Audio Effects (DAFx-07)*, pp. 237-244, Bordeaux, France, September 10-15.
- Laurier, C., Meyers, O., Serra', J., Blech, M., Herrera, P. (2009), Music Mood Representation from Social Tags. *Proceedings of the 10th International Society for Music Information Conference*, Kobe, Japan.
- Levy, M. Sandler, M. and Casey, M. (2006), Extraction of High-Level Musical Structure From Audio Data and Its Application to Thumbnail Generation. *Proc. of ICASSP'06*, Vol. 5, Toulouse, France, 13-16.
- Moon, C.B., Kim, H.S., Lee, H.A. and Kim, B.M. (2014), Analysis of relationships between mood and color for different musical preferences, *Color Research & Application*, vol. 39, Issue 4, pp. 413-423.
- Russell, J.A. (1980), circumplex model of affect. *Journal of Personality and Social Psychology*, No. 39, 1161.
- Ryu, S.-J., Lee, H.-Y., Cho, I.-W. and Lee, H.-K. (2008), Document Forgery Detection with SVM Classifier and Image Quality Measure. *Lecture Notes in Computer Science*, vol.5353, pp.486-495.
- Steven R. Ness, Anthony Theocharis, George Tzanetakis and Luis Gustavo Martins (2009), Improving Automatic Music Tag Annotation Using Stacked Generalization Of Probabilistic SVM Outputs. *Proc. of ACM MM'09*, pp.705-708.
- Thayer, R.E. (1989), *The Biopsychology of Mood and Arousal*, New York. Oxford University Press.

# Geografic Information System for Optimization of Lane Road in Bandar Lampung Using Dijkstra Algorithm

**Triyugo Winarko**

STMIK Mitra Lampung  
e-mail:triyugo\_win@umitra.ac.id

## ***Abstract***

*Geografic Information System (GIS) is a tool to store, manipulate, analyze and display back with the help of natural conditions and spatial attribute data. One implementation of a Geografic Information System is the shortest route search in order to obtain the efficiency of time and travel expenses. In this research the method used to find the shortest lane is by using Dijkstra's algorithm. This algorithm uses a greedy principle, greedy is negative implies that takes all the possibilities that exist without thinking about the future consequences. These algorithms solve the problem step by step. Of the various measures taken the best decision in determining which is the best step. This research aims to resolve problems on the network routing lane, Geografic Information System (GIS) in Bandar Lampung using dijkstra algorithm.*

**Keywords :** *Dijkstra Algorithm, GIS, Shortest Lane*

## **1 INTRODUCTION**

Geografic Information System (GIS) is a technology that provide a tool to store, manipulate, analyze and display back of natural conditions with the help of attribute data and spatial. Geografic Information Systems (GIS) not only displays the attribute data, but also can display data grafically and their attributes, making it easier for users to obtain information.

Geografic Information Systems (GIS) can be used as a tool, an example of the determination of lanes in a region with the provisions of getting the right lane to pass in order to get the efficiency of travel time, and determining an alternate lane to be traversed. For the purpose of this research is to design a lane optimization system in Geografic Information Systems (GIS) of Bandar Lampung city.

This system is expected to determine the optimum lane road from two different places in order to get the efficiency of travel time by choosing the right lane. As well as providing information about the public facilities located in the city of Bandar Lampung. Search the shortest lane become indispensable in daily life example for motorists, routing computer networks and telephone networks. Determination of shortest lane has the advantage of time and cost efficiency.

## 2 RESEARCH METHODOLOGY

Geographic Information System (GIS) is a system or set of objects, ideas interconnected that aims to display geographic information so that it can be a software technology that can process, store, analyze, manipulate and transform spatial data or return information on natural conditions and their attributes and spatial. The data model used in Geographic Information Systems (GIS) is used data presented form the real world into the database. Form of representation of spatial entity is the concept of raster and vector. In this case the use of two models of raster data (images) and vector data model (lines and points).

Graf is a representation of discrete objects and the relationships between these objects, the visual representation of a graf is to declare the object as node, circles, or dots, whereas the relationship between the object represented by a line. Graf is expressed by the symbol  $G$  is defined as the set of pairs  $(V, E, K)$ , which in this case;

$V$  = The set is not empty of vertices (node)

=  $v_1, v_2, v_3, \dots, v_n$

$E$  = The set of sides (edges or arcs) connecting a pair of vertices

=  $e_1, e_2, e_3, \dots, e_n$

$K$  = Bobot

Vertices or nodes can not be empty while the edges or arcs can be empty. so, a possible graf does not have any side, but vertices there must be, at least one. Vertices of the graf can be represented with letters such as a, b, c ..... z with the natural numbers 1, 2, 3 ... .n or a combination of both. While connecting the node  $v_i$  to node  $v_j$  expressed by  $(v_i, v_j)$  or the symbol  $e_1, e_2, e_3, \dots$ . If  $e$  is the side that connects node  $v_i$  to node  $v_j$ , then  $e$  can be written as  $e = (v_i, v_j)$ .

In determining the shortest path there are various algorithms such as exhaustive search, Greedy algorithm, dynamic program, Kruskal algorithm and Dijkstra's algorithm. In this research used dijkstra algorithm, because this algorithm has advantages compared with other algorithms. The algorithm has a faster execution time in finding the shortest route compared with other algorithms.

Dijkstra's algorithm is a greedy algorithm to solve the problem of the shortest distance (shortest lane problem) for a directed graf or undirected graf with edge value are worth no negative so it is assumed that  $k(v_{ij}) \geq 0$  for all edges  $(v_{ij}) \in E$ . With dijkstra algorithm can resolve the path / shortest route from a vertex of origin and destination vertices in a value graf  $G = (V, E)$ . The shortest distance is obtained from two vertices if the total value of all the edges in the graf network is the most minimal.

Here are the steps to finding the shortest path using Dijkstra's algorithm:

1. Graf made represented in the matrix  $K=[v_{ij}]$ 
  - $v_{ij}$  = edge value  $(i,j)$ .
  - $v_{ii} = 0$
  - $v_{ij} = \infty$ , if there is no path from node  $v_i$  to node  $v_j$ .
  
2. Create a table  $S = [s_i]$ 
  - $s_i = 1$ , if node  $i$  including the shortest path.

Table 1: Representation graf with 6 vertices

	A	B	C	D	E	F
A	0	8	2	6	$\infty$	$\infty$
B	8	0	$\infty$	$\infty$	12	$\infty$
C	2	$\infty$	0	$\infty$	15	$\infty$
D	6	$\infty$	$\infty$	0	$\infty$	4
E	$\infty$	12	15	$\infty$	0	6
F	$\infty$	$\infty$	$\infty$	4	6	0

$s_i = 0$ , if node  $i$  is not including the shortest path.

3. Create table  $D = [d_i]$  is the distance from the start node to the start node to the start node to the destination node.

```

function Dijkstra (G, k, s) // dijkstra function declaration
for each vertex v in V[G] // initialize all vertex value in a graf G
d[vj] := infinity // vertex value to j be stored on an infinite array previous[vj] := undefined
// vertex value to j previously unknown
d[s] := 0 // set 0 in the array to the node s not including the shortest path
S := empty set // set variabel S = 0
Q := V[G] // set variable Q with vertex value in a graf G
while Q is not an empty set // variable Q initialization
vi := Extract_Min(Q) // vertex value set to i
S := S union vi // set of variabels S
for each edge (vi,vj) // initialization of each edge in the graf
if d[vi] + k(vi,vj) < d[vj]
d[vj] := d[vi] + k(vi, vj)
previous[vj] := vi

```

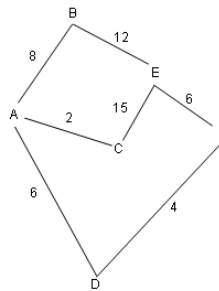

Figure 1: Graf with 6 vertices

### 3 RESULTS AND DISCUSSION

In this research the object under research is on the main road located in the city of Bandar Lampung and their attributes. Research is also carried out by looking at the location of public places, hotels, hospitals, restaurants, and tourist spot located in the city of Bandar Lampung. In the search for the shortest route in the city of Bandar Lampung lane researchers used data obtained by measuring the length of a conventional is lane road from one place to another on the map with a scale of 1: 27,500 which means that 1 cm on the map represent the actual distance of 0.27 kilometer in the actual distance. The data obtained is the distance between the location of public places such as hospitals, hotels, tourism objects, universities, colleges, restaurants, terminals, ring road and other public places.

Here is the implementation of Dijkstra's algorithm on a graf having 11 vertices with value each of which represents the distance between the vertex. Vertices in the graf can represent a place or a ring road in a geographical area.

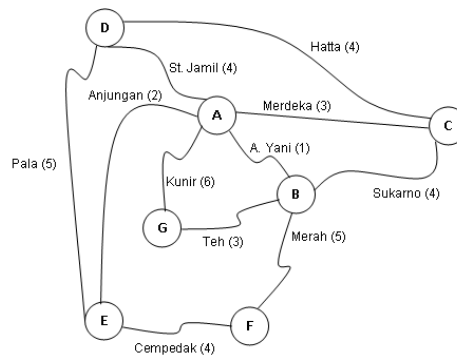

Figure 2: Graf lane with 7 edge

In determining the shortest path in the graf above the required starting point and destination point. For example the initial point D to point destination F with the tree diagram we can know which path can be passed, with provisions lane road that has been passed by the same route should not be passed again and if it has arrived at the destination point on the route stop search and resume by another route, if the route has traversed all we can infer which route to be traversed with the optimum distance or shortest.

From the tree diagram can be determined route to reach the goal of vertices D to F vertices are:

$D \Rightarrow A \Rightarrow B \Rightarrow F$  with total distance = 10

$D \Rightarrow A \Rightarrow G \Rightarrow B \Rightarrow F$  with total distance = 18

$D \Rightarrow C \Rightarrow B \Rightarrow F$  with total distance = 13

$D \Rightarrow E \Rightarrow F$  with total distance = 9

From these results the shortest distance is D E F with a total distance of 9. In the application of Dijkstra's algorithm on the graf above is not a directed graf, but Dijkstra's algorithm can also be applied on a directed graf.

In the search for the shortest route in the city of Bandar Lampung lane be required data such as data lanes, places and regions. The data is then processed in the database so that it

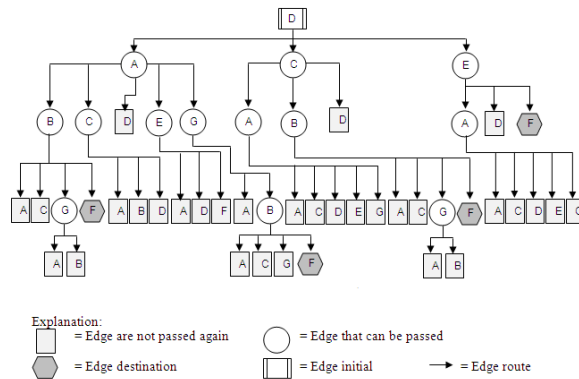

Figure 3: Shortest route search tree diagram

will form a closed graf representing a network of roads in the city of Bandar Lampung. The place and the ring road is assumed as the vertex is a point on the graf and lane as the edge value is within two vertex  $G = (V, E)$ . All edge value are not negative so it is assumed that  $k(u, v) \geq 0$  for all edges  $(u, v) \in E$ .



Figure 4: Map of road network Bandar Lampung city

From lane road network map of Bandar Lampung we can make a graf of the road network by entering the data vertex and edge with the value of each lane which is the distance to the database. From the graf that has been formed we can find the shortest route for example from the starting point is the point A is the vertex representing the Islamic Center Mosque and point B which is the goal of vertices representing Urip Sumoharjo hospital. From these two places we can find the shortest route to dijkstra algorithm. With the same method on the shortest route search graf Figure 3 obtained with the shortest distance 5107 km route Start = JI Campus Unila = JI Sumantri Bojonegoro = JI ZA Pagar Alam = JI Teuku Umar = JI Urip Sumoharjo = Finish .

With optimum distance we can determine the travel time to determine the speed of the vehicle as an example of an average vehicle speed of 60 km / hour, the time required from the Islamic Center Mosque to Urip Sumoharjo hospital is 0.08511666666666667 hours or 5.1070000000000002 minutes or 5 minutes 107 seconds, with never stop at all travelled.

The results obtained from:

$$t = \frac{s}{v} \tag{1}$$

## 4 CONCLUSION

In optimization lane in the city of Bandar Lampung with dijkstra algorithm takes the initial position and the position of the destination which is two places or ring road, the two positions will be formed with the optimum distance or shortest. Distance of the search results can be used to find the shortest travel time is faster than the travel time to the other with the same destination and the same determination vehicle speed. This lane optimization system can help the Bandar Lampung community or tourists to find the shortest route to reach the public places and facilities available in the city. In search of the shortest route possibilities other vertices are not passed because it is too far away and not used in the calculation. In the graf on the lane formation of Bandar Lampung, the more complex will reduce the efficiency of the time because it takes a long time. The more complex road network then the search will require considerable time. By determining the shortest path route path will produce the advantage that the efficiency of time and travel expenses.

## 5 ACKNOWLEDGEMENTS

Praised be to Allah who has given His blessing so that author can finish this research. This research dedicate to beloved daughter *Ayesha Nafiza Winarko*, hopefully soon be able to contribute more to religion, nation, and state.

## References

- Algoritma Dijkstra .[http://id.wikipedia.org/wiki/Algoritma\\_Dijkstra](http://id.wikipedia.org/wiki/Algoritma_Dijkstra), diakses: 2 Januari 2015.
- Boost C++ libraries. Dijkstra visitor Concept. <http://www.boost.net>. diakses: 22 Desember 2014.
- Collins, William J., College Lafayettee. (1992),*Data Structures An Object-Oriented Approach*. Reading, MA: Addison Wesley.
- Dijkstras Algorithm. [http://www.algorithmist.com/index.php/Dijkstra%27s\\_algorithm](http://www.algorithmist.com/index.php/Dijkstra%27s_algorithm). diakses: 3 Januari 2015.
- Dijkstra Algorithm. [http://students.ceid.upatras.gr/%7Eepapagel/project/kef5\\_7.htm](http://students.ceid.upatras.gr/%7Eepapagel/project/kef5_7.htm). diakses: 20 Desember 2014
- Fajar, indra. Siregar, Gustian. Tarwidi. Dede. (2014), Algoritma Mencari Lintasan Terpendek. <http://www.informatika.org/rinaldi/stmik/makalah/makalahstmik27.pdf>. diakses: 20 Desember 2014
- Hidayat,Taufiq, Munir, Qomaruddin, Agus. *Perancangan Sistem Informasi Geografis Penentuan Jalur Jalan Optimum kodya*, Yogyakarta: SNATI.
- Imron, Chairul. Suprayitno, Hitapriya. Pahlevy C R ,Reza, Metode Pembebanan All Or Nothing Dengan Perataan Rute Pesain. <http://sawit.usu.ac.id/ft/fts/simpFSTPT4>. diakses: 3 Januari 2015
- Sistem Informasi Geografis. <http://id.wikipedia.org/wiki/sisteminformasigeografis>. diakses: 27 Desember 2014.



# Implementation and Analysis of LCAS (Link Capacity Adjustment Scheme) Encapsulation on Ethernet Over SDH (Synchronous Digital Hierarchy) for A Reliable Network

Beny Nugraha, Abdaul Hidayatir Ridho

Universitas Mercu Buana

e-mail:beny.nugraha@mercubuana.ac.id, abdaul.hidayatir@gmail.com

## *Abstract*

*Ethernet over SDH (Synchronous Digital Hierarchy) is a popular technology that is able to fulfill the need of reliable and fast data transmission, Ethernet over SDH is able to provide throughput up to 10 Gbps. However, one problem is found when the throughput is being downgraded or upgraded, in Ethernet, the change of throughput value can lead to an interrupt traffic, which is shown by the decline of the throughput value to 0 Mbps. One solution that can be applied to overcome the problem is the LCAS encapsulation. With LCAS, the change of throughput will have no negative effect in the network. The result of this research shown that LCAS is able to avoid interrupt traffic, it is shown that for the LCAS implemented network, the throughput value is only change in accordance to the downgrade and upgrade value, thus maintain the reliability of the network. Meanwhile, for the network that is not implemented with LCAS, the throughput value is decline to 0 Mbps.*

**Keywords :** Downgrade, Ethernet over SDH, LCAS, throughput, upgrade

## 1 INTRODUCTION

Ethernet over SDH (Synchronous Digital Hierarchy) is a technology that enables the payload transmission process is working in synchronous because it uses clock to synchronize the sources bits with the receivers bits. Moreover, Ethernet over SDH is able to provide a fast data transmission with throughput up to 10 Gbps. However, a problem, which is interrupt traffic, arises when the throughput is downgraded or upgraded. Interrupt traffic occurs because when the throughput value is changed, the network will do the cross-connect creation and traffic restarting processes, which are time consuming, thus, cannot accommodate the change. In order to solve this problem, LCAS (Link Capacity Adjustment Scheme) encapsulation technology is presented. One advantage of LCAS encapsulation is, the change of the throughput value will not lead to the interrupt traffic. Ethernet over SDH and LCAS encapsulation are described further in below subsections.

## 1.1 Ethernet over SDH

Ethernet over SDH is an improvement of the existing SDH. Ethernet over SDH is able to provide not only fast data transmission, but also a reliable network. Two techniques that allow Ethernet traffic to flow in an SDH network is the GFP (Generic Framing Procedure) and the VCat (Virtual Concatenation). The GFP provides functions to adjust the Ethernet traffic to flow in the SDH network; meanwhile the VCat is able to separate the GFP-adapted traffic into different paths in the SDH network.

## 1.2 LCAS

ITU-T Recommendation G.7042/Y.1305 described a protocol that is able to dynamically increase or decrease the available throughput. This method is called LCAS and it allows the throughput value to be adjusted without having interrupt traffic. Illustration of the LCAS can be seen in Figure 1.

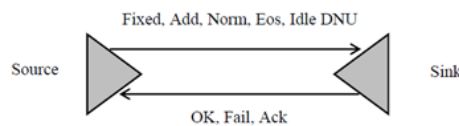

Figure 1: LCAS Illustration

This paper will present the result of the simulation of LCAS encapsulation to an Ethernet over SDH, which prove that LCAS encapsulation will be able to maintain the network reliability. The rest of this paper is organized as follows: In Section 2, the implementation of LCAS on Ethernet over SDH is described. In Section 3, the simulation result as well as the analysis of the result is presented. Finally, the conclusions are discussed in Section 4.

## 2 IMPLEMENTATION OF LCAS ON ETHERNET OVER SDH

### 2.1 Simulation Design

This research uses the Multiplexer MN Series 2300, 3100 and 4100. The multiplexers are designed in accordance with the ring topology and it uses 1+1 SNCP (Sub-network Connection Protection) protection. Moreover, the primary route (the working route) is using STM-64 and the secondary route (the protection) is using STM-16. These protections are used to minimize an error in the SDH transport route when the simulation is run.

Figure 2 illustrates the simulation design that is used in this research, the connection between the multiplexer and the NMS (Network Monitoring System) has to be connected well so that the multiplexer can be monitored in the NMS also it can be configured remotely.

In order to get the result from the network, a BER test tool is used, the series of the BER tester is EXFO-FTB200. Once the entire network element integrated nicely with the NMS, the BER tester is connected to the Ethernet card. The next step is to create the DXC (Digital Cross Connect) of the VC (Virtual Container). There are three level VCs that are used in this research, they are VC-12, VC-3 and VC-4. Each VC has different standard of throughput value, VC-12 has 2.084 Mbps, VC-3 has 48.384 Mbps, and VC-4 has 155.52 Mbps. The purpose of using three different VCs is to show the characteristic of each VC

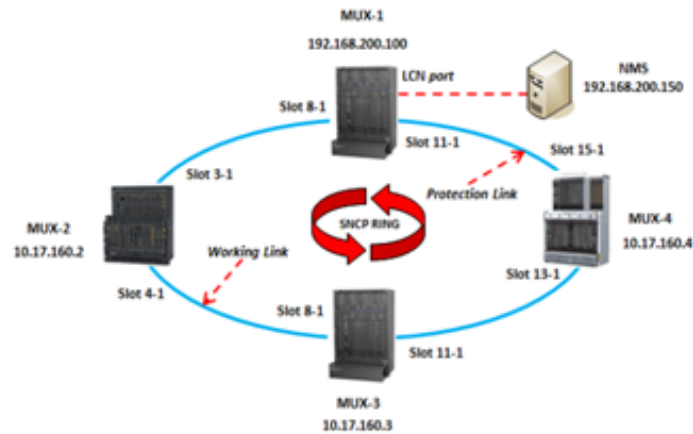

Figure 2: Simulation Design

Table 1: Throughput Allocation for Each VC

Level	Throughput Allocation
VC-12	10.24 Mbps = 5 x VC-12
VC-3	241.92 Mbps = 5 x VC-3
VC-4	777.6 Mbps = 5 x VC-4

when implemented with the Ethernet over SDH. Once the creation of the DXC is done, the next step is to allocate the throughput or making the VCG (Virtual Container Group) on the Ethernet card. This throughput is allocated in MUX 1 and MUX 3, which will play the role of the sender and receiver, respectively. The throughput allocation for each VC level can be seen in Table 1.

The above throughput allocation will be the existing throughput, which is used as the initial point, furthermore, the existing throughput will be downgraded and upgraded to see the effect on the network performance. The result of the simulation is presented in Section 3.

### 3 RESULTS AND ANALYSIS

The scenario for the simulation is as follow, on each level of the VC (VC-12, VC-3, and VC-4) will be run simulation in the form of throughput downgrade and upgrade. The simulation will be run on a LCAS-implemented Ethernet over SDH network and on a Ethernet over SDH without LCAS. The result will be compared to prove that LCAS is able to prevent the interrupt traffic. The value of throughput after the downgrade and upgrade is shown in the BER tester. The scenario for the simulation can be seen in Table 2.

From the above table can be seen that there are in total 12 downgrading and upgrading scenarios, where the first simulation is by downgrading the throughput of the VC-12 from 5 x VC-12 (10.24 Mbps) by the value of 2 x VC-12 (4.168 Mbps), the second simulation is by downgrading the throughput of the VC-12 from 5 x VC-12 (10.24 Mbps) by the value of 4 x VC-12 (8.336 Mbps), and so on until the twelfth simulation where the throughput of VC-4 is

Table 2: Scenario for Downgrading and Upgrading the Throughput

Level	Existing throughput	Downgrade throughput	Upgrade throughput
VC-12	5 x VC-12 = 10.24 Mbps	2 x VC-12 = 4.168 Mbps	6 x VC-12 = 12.504 Mbps
		4 x VC-12 = 8.336 Mbps	7 x VC-12 = 14.588 Mbps
VC-3	5 x VC-3 = 241.92 Mbps	2 x VC-3 = 96.768 Mbps	6 x VC-3 = 290.304 Mbps
		4 x VC-3 = 193.536 Mbps	7 x VC-3 = 338.688 Mbps
VC-4	5 x VC-4 = 777.6 Mbps	2 x VC-4 = 311.04 Mbps	6 x VC-4 = 933.12 Mbps
		4 x VC-4 = 622.08 Mbps	7 x VC-4 = 1088.64 Mbps

Table 3: VC-12 Simulation Result

Existing Throughput	No.	Throughput After Downgrade/Upgrade		
		Downgrade/Upgrade Throughput	Without LCAS	With LCAS
5 x VC-12 = 10.24 Mbps	1	2 x VC-12 = 4.168 Mbps	0 Mbps	6.072 Mbps
	2	4 x VC-12 = 8.336 Mbps	0 Mbps	1.904 Mbps
	3	6 x VC-12 = 12.504 Mbps	0 Mbps	22.744 Mbps
	4	7 x VC-12 = 14.588 Mbps	0 Mbps	24.828 Mbps

upgraded from 5 x VC-4 (777.6 Mbps) by the value of 7 x VC-4 (1088.64 Mbps). Each of the above scenarios is run without and with LCAS implemented, therefore, there are in total 24 simulations.

The result for VC-12 simulation with and without LCAS implemented can be seen in Table 3.

Figure 3 illustrates the comparison graph of the VC-12 simulation between the without LCAS implemented and with LCAS implemented.

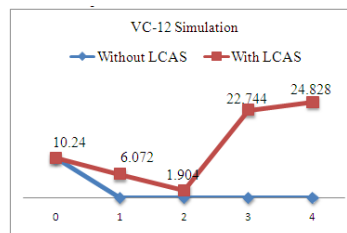

Figure 3: VC-12 Simulation Comparison Graph Between the Without LCAS Implemented and With LCAS Implemented

From the Table 3 and Figure 3 it can be seen that when LCAS is not implemented, the change in the value of the throughput will result in the decline of the throughput value to 0 Mbps, this mean there is an interrupted traffic. Meanwhile, when LCAS is implemented, the change in the value of the throughput will only change the throughput in accordance with the changed value. For example, in simulation no. 1, the existing throughput is 5 x VC-12

Table 4: Examples of writing table

Existing Throughput	No.	Downgrade/Upgrade Throughput	Throughput After Downgrade/Upgrade	
			Without LCAS	With LCAS
5 x VC-3 = 241.92 Mbps	1	2 x VC-3 = 96.768 Mbps	0 Mbps	145.152 Mbps
	2	4 x VC-3 = 193.536 Mbps	0 Mbps	48.384 Mbps
	3	6 x VC-3 = 290.304 Mbps	0 Mbps	532.224 Mbps
	4	7 x VC-3 = 338.688 Mbps	0 Mbps	580.608 Mbps

(10.24 Mbps), then it is downgraded by the value of 2 x VC-12 = 4.168 Mbps, and from the BER tester can be seen that the current throughput is 6.072 Mbps, which is only a reduction between the existing throughput and the downgraded value.

The result for VC-3 simulation with and without LCAS implemented can be seen in Table 4.

Figure 4 illustrates the comparison graph of the VC-3 simulation between the without LCAS implemented and with LCAS implemented.

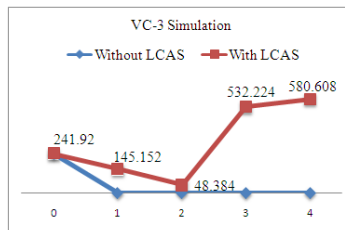

Figure 4: VC-3 Simulation Comparison Graph Between the Without LCAS Implemented and With LCAS Implemented

It can be concluded from the Table 4 and Figure 4 that when LCAS is not implemented, and when the throughput value is changed, then the current throughput value is down to 0 Mbps, meanwhile, when LCAS is implemented, the change in the value of the throughput will only deduct or add the existing value with the changed value, the same with the VC-12 simulation. The result for VC-4 simulation with and without LCAS implemented can be seen in Table 5.

It can be concluded from Table 5 that LCAS is able to prevent the interrupt traffic because when LCAS is implemented, the change of the throughput value will not bring down the current throughput to 0 Mbps, the current throughput value will only change in accordance to the downgraded and upgraded value instead. For example in simulation number 4, the existing throughput is 777.6 Mbps, then it is upgraded by 1088.64 Mbps, the result is, the current throughput is 1866.24 Mbps, which is an addition between the existing throughput and the upgraded throughput.

Figure 5 illustrates the comparison graph of the VC-4 simulation between the without LCAS implemented and with LCAS implemented.

Table 5: VC-4 Simulation Result

Existing Throughput	No.	Downgrade/Upgrade Throughput	Throughput After Downgrade/Upgrade	
			Without LCAS	With LCAS
5 x VC-4 = 777.6 Mbps	1	2 x VC-4 = 311.04 Mbps	0 Mbps	466.56 Mbps
	2	4 x VC-4 = 622.08 Mbps	0 Mbps	155.52 Mbps
	3	6 x VC-4 = 933.12 Mbps	0 Mbps	1710.72 Mbps
	4	7 x VC-4 = 1088.64 Mbps	0 Mbps	1866.24 Mbps

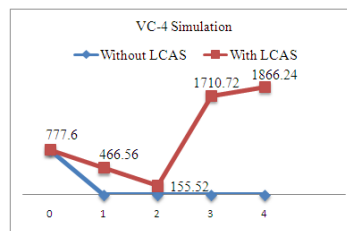

Figure 5: VC-4 Simulation Comparison Graph Between the Without LCAS Implemented and With LCAS Implemented

#### 4 CONCLUSION

Conclusions that can be derived from this research are:

1. The simulations that are run in the non-LCAS network shows that by downgrading or upgrading the throughput then there is interrupt traffic, which is indicated by the current throughput value decline to 0 Mbps.
2. Meanwhile, the simulations that are run in the LCAS-implemented network show that the throughput values only change in accordance with the downgrade and the upgrade value.
3. According to the above results, LCAS is proven to be able to avoid the interrupt traffic, thus, maintaining the reliability of the network.

#### References

- Alberti, Antonio Marcos and Fernandes, Roulien, (2011), Ethernet-over-SDH: Technologies Review and Performance Evaluation. *Revista Telecomunicaes*, Vol. 13, No. 01.
- ITU-T., (2011), *Recommendation G.7042/Y.1305, Link Capacity Adjustment Scheme (LCAS) for Virtual Concatenated Signals*.
- ITU-T., (2003), *Recommendation G.7041/Y.1303, Generic Framing Procedure (GFP)*.
- ITU-T., (2000), *Recommendation G.707/Y.1322, Network Node Interface for the Synchronous Digital Hierarchy (SDH)*.

# Password Designing Using Programmable Logic Device (PLD)

Muhammad Irmansyah, Era Madona, Nasrul

Electrical Department, Polytechnic State of Padang  
Campus of Polytechnic State of Padang Limau Manis  
Padang, West Sumatera, Indonesia  
e-mail:emadona38@gmail.com

## **Abstract**

*Password can be applied as electronics key in security system. For example, it use to electronics key to wardrobe door or safety deposit box. This electronics key use the password code as a key that entered by the user to unlock the door. Base concept of Programmable Logic Device (PLD) is how to construct a programmable combinational logic circuit. The ability of PLD programming is planned at hardware level. PLD is a chip with high purpose to control the hardware base on it specification. PLD as digital logic IC can be change it functions using the programming language Hardware Description Language (HDL). The software that use is Warp 4.2 from Cyress. Using Personal Computer (PC), program logic or state diagram can be made by HDL using software text editor. HDL is compiled using software to make the logic circuit detail and produce the output of design that has been done. The circuit operation is simulated in NOVA checked the output of program suitable with user needed. PLD technology can be applied to password code with password code 527 to activated three output Y0, Y1 dan Y2.*

**Keywords :** *Programmable Logic Device (PLD), Hardware Description Language (HDL), Password*

## 1 INTRODUCTION

Password is a word or string of characters used for user authentication to prove the identity or access to system, which must be kept secret from those not allowed access. Passwords are generally short, easy to remember and type. Password can be applied as electronics key in security system. For example, it use to electronics key to wardrobe door or safety deposit box. This electronics key use the password code as a key that entered by the user to unlock the door.

Programmable Logic Devices (PLD) technology is digital logic integrated circuit (IC) that can be changed the function using programming. Using PLD technology users can make own design and model that they want and need. It also can be reprogram and reconfigure the designing as user needed. Figure 1 shows how to built digital circuit using PLD easily. Base concept of Programmable Logic Device (PLD) is how to construct a programmable

combinational logic circuit. Combinational circuit is a circuit without memory device inside the system. The ability of PLD programming is planned at hardware level. In another word, PLD is a chip with high purpose to control the hardware base on it specification. By using unexpensive personal computer (PC), software program and a programmable logic devices (PLD) IC, a digital circuit can easily prototype. The five step process for creating a prototype using a PLD:

- Step 1 : Create the new circuit using the text editor or softwares schematic editor
- Step 2 : Compile the circuit into a bitstream file (file.jed) that when this file loaded into the PLD, will instruct it to act like the entered schematic
- Step 3 : Verify the operation of circuit using the softwares functional and timing simulator (NOVA)
- Step 4 : Download the circuit file from the PC to the PLD
- Step 5 : Physically test the PLD by activating its input and monitoring its output

This programmable logic prototyping method has the following advantages with manual wiring reduced to a minimum, prototypes can be constructed, tested, and modified at a much faster rate, wiring errors can be avoided, can experiment with many digital IC types without having to stock them, circuit design can be saved as electronic files within the PC and use again when needed, since the PLD can be used over and over, modifications can be easily be made by altering the circuit in the PC and then downloading the new design into the IC of PLD.

Hardware Description Language ( HDL ) is a high-level programming language used to program a digital IC. It consists of a number of gates which can be programmed by disconnecting fuse inside the IC. Such as a programming language, HDL has its own rules in hierarchies or systematic program until the syntax used. HDL technology is classified by the number of existing gates. Programmable Logic Device (PLD) has less than 500 gates. A programming language that used is Warp 4.2 from Cyress. This software will produce a file with extension \*.jed and can be downloaded to IC using IC programmer such as the All - 07, Easy Pro and others. Programming by using WARP 4.2 must obey the rules of programming that has been set by the vendor. Although programming language come from the different vendors but relatively the same because they use the reference to the international standard IEEE. General description of HDL programming technique can be seen in following explanation. There are two parts that must exist in programming:

1. Entity Declaration, entity declarations describe the input and output on the design of entity. It shows the values of the parameters. Entity declaration similar with the symbol scheme, which describes the relationship of component based design. Ports can be said to be a pin in the schematic symbol. Each port must have own name (identity), the direction (mode) and the clear type of data.
2. Architecture Body, Each architecture body integrated with an entity declaration. Architecture describes the contents of entity that declares an entity function also. If the entity declaration is displayed as a 'black box', which is the input and the output was



Table 1: Truth Table Design of Input dan Output Password

KODE	INPUT				OUTPUT		
PASSWORD	X1	X2	X1	X0	Y0	Y1	Y2
5	0	1	0	1	1	0	0
2	0	0	1	0	1	1	0
7	0	1	1	1	1	1	1

already known , while what is inside is not known , then the architecture that the contents of the black box that describes a function entity . There are three ways in architecture design, they are behavioral, dataflow, structural description atau mixing.

In this research is constructed the electronics key using Programmable Logic Device (PLD) technology using Hardware Description Language (HDL).

## 2 RESEARCH METHODOLOGY

The first step to design the password using PLD is design the program algorithm for HDL that familiar with stateCAD. The password for this study is three code digit 5, 2 and 7. Each digit consist of four biner bits are X0,X1,X2,X3 and in the system they have function as input. The outputs are coded as Y0,Y1 and Y2. If the combination of the password code that entered to the system is correct, then the output bit activated.

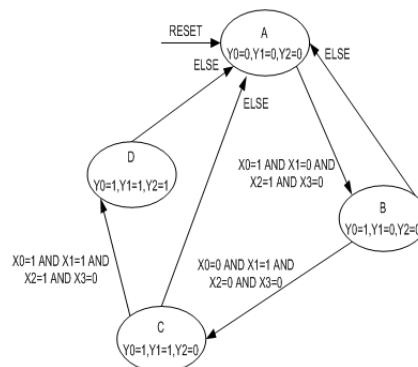

Figure 1: StateCAD diagram (Algorithm program) to Password "527"

The second step of this design constructs the circuit in Hardware Description Language (HDL) using text editor programming. In this case, the programming is used to substitute the function of circuit in programming language.

Listing program to Password using software WARP 4.2 with Hardware Description Language (HDL):

The circuit in program HDL form need to compile and change it becomes bitstream file with jed extension.

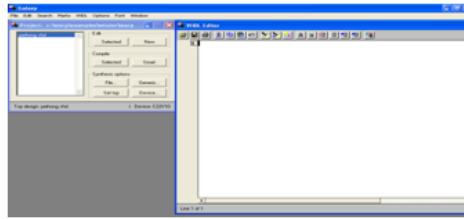

Figure 2: Text editor to typing the program

#### Declaring a Component (Device) and Entity Declaration

This part is declared the pin function in the password system, some pins as input and some are output.

```
use ieee.std_logic_1164.all;
entity peihong is
port (CLK,RESET,X0,X1,X2,X3: in std_logic;
Y0,Y1,Y2:out std_logic);
signal BP_Y0,BP_Y1,BP_Y2: std_logic;
end;
signal sreg : std_logic_vector (2 downto 0);
signal next_sreg : std_logic_vector (2 downto 0);
constant A : std_logic_vector (2 downto 0) := "000";
constant B : std_logic_vector (2 downto 0) := "001";
constant C : std_logic_vector (2 downto 0) := "010";
constant D : std_logic_vector (2 downto 0) := "011";
```

#### Architecture Body (Behavioral Description)

This part shows the procedure of passwords identifications. The output in HDL will active when the reset got the low input and clock active. This condition activated the output Y0, Y1 and Y2 trough the input X0,X1 and X2.

```
begin
process (CLK,RESET,next_sreg)
begin
if (RESET='1') then
sreg <= A;
elsif CLK='1' and CLK'event then
sreg <= next_sreg;
end if;
end process;
begin
process (sreg,BP_Y0,BP_Y1,BP_Y2,X0,X1,X2,X3)
BP_Y0 <= '0'; BP_Y1 <= '0'; BP_Y2 <= '0';
next_sreg<=A;
case sreg is
when A =>
BP_Y0<='0';
BP_Y1<='0';
BP_Y2<='0';
if (X0='1'and X1='0'and X2='1'and X3='0') then
next_sreg<=B;
else
```

The password design can be simulated using functional software and timing simulator, NOVA. The basic timing diagram is shown in figure 4 that have 4 inputs (X0,X1,X2,X3) and three outputs (Y0,Y1,Y2).



Figure 3: Compiling result for the password design

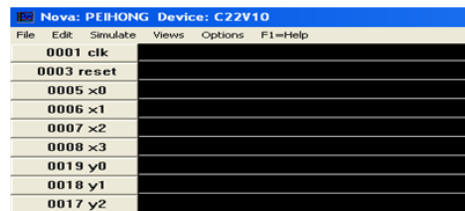

Figure 4: Basic timing diagram of NOVA

### 3 RESULTS AND DISCUSSION

The HDL programming for password design is simulated in NOVA software and got the result as shown in figure 5.

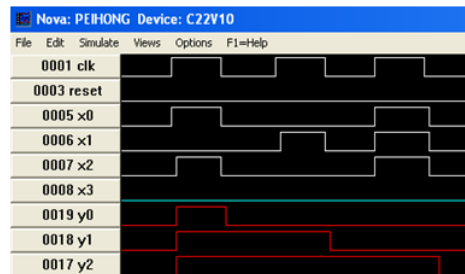

Figure 5: Timing diagram of password code simulations

The timing diagram shows the password input  $x_0, x_1, x_2$  and  $x_3$  and output  $y_0, y_1$  and  $y_2$ . Input code password 5 identical with biner 0101, input code password 2 identical with biner 0010 and input code 7 identical with biner 0111 and coded in  $x_0, x_1, x_2$  and  $x_3$ . Input biner combination triggered the output  $y_0, y_1$  and  $y_2$ . In timing diagram, the first high clock have the value of  $x_0 = 1, x_1 = 0, x_2 = 1$  and  $x_3 = 0$  as biner combination of code password 5 and produced the combination of output  $y_0 = 1, y_2 = 0$  and  $y_3 = 0$ . The second high clock have the value of  $x_0 = 0, x_1 = 1, x_2 = 0$  and  $x_3 = 0$  as biner combination of code password 2 and produced the combination of output  $y_0 = 1, y_2 = 1$  and  $y_3 = 0$ . The third high clock have the value of  $x_0 = 1, x_1 = 1, x_2 = 1$  and  $x_3 = 0$  as biner combination of code password 7 and produced the combination of output  $y_0 = 1, y_2 = 1$  and  $y_3 = 1$ . It means, the first code

Table 2: Input and Output Password

KODE	INPUT			OUTPUT			
PASSWORD	X1	X2	X1	X0	Y0	Y1	Y2
5	0	1	0	1	1	0	0
2	0	0	1	0	1	1	0
7	0	1	1	1	1	1	1

activated the y0 output, second code for y1 and the last code for y2 output. Comparing with the password designing, the result show in the timing diagram has the same specification with designing as seen in the table below.

#### 4 CONCLUSION

1. Programmable Logic Device (PLD) using programming language Hardware Description Language (HDL) can be a password.
2. The password in HDL is labeled input into X2, X1 and X0 with configuration 5 = 101b, 2 = 010b and 7 = 111b.
3. Code applied in this password is 527 to activated three outputs, 5 to Y0, 2 to Y1 and 7 to Y2.

#### References

- Irmansyah,M, (2008), *Programmable Logic Device (PLD) Trainer*, DIPA Research Polytechnic State of Padang.
- Irmansyah,M, (2009), Logic Gate base on Programable Logic Device (PLD), *Jurnal Elektronik* Vol. 2 No.1, Polytechnic State of Padang.
- Irmansyah,M, (2009), Multiplexer base on Programable Logic Device (PLD), *Jurnal Elektronik* Vol. 1 No.2, Polytechnic State of Padang.
- Irmansyah,M, (2010), Decoder Biner to Decimal base on Programable Logic Device (PLD), *Jurnal Elektronik* Vol. 1 No.1, Polytechnic State of Padang.
- Kevin Skahill, (1997), *VHDL for Programable*, Addison Wesley.
- Nigel P,Cook, (2004), *Practical Digital Electronics*,Prentice Hall.
- Setiawan,Rahmat, (2009), *Guidance of PLD Laboratory*,Surabaya.
- Stephen Brown, (2000), *Digital Logic Of Fundamentals With VHDL Design*,Mcgraw-Hill.  
<http://www.wikipedia/password>

## Risk Management Framework in Information Technology Outsourcing Project

Arif Ridho Lubis, Husni Lubis, Ihsan Lubis

Sekolah Tinggi Teknik Harapan  
e-mail:arifridholubis@gmail.com, husni.lubis82@gmail.com, ihsan.lubis@gmail.com

### **Abstract**

*Company, at the present time, is definitely in need of information technology. Performance of the company is judged not only from the financial and assets but also from the discussing all aspects that should provide cost leadership, differentiation and focus. Problems frequently appears in the company such as not achieving the goal, inappropriate labor standards, outsourcing standard that does not meet the company criteria, the leakage of company's information security. By applying interview method, we would like to know about how the company deals with the practice of outsourcing that will be applied by their company, the reason they hire outsourcing, benefits for the company itself and the method applied to outsourcing. The result stated that there are three main points of IT outsourcing to improve IS, that is to improve the business performance, to generate new revenue and that can help companies to assess outsourcing.*

**Keywords :** *Information Technology Outsourcing, Risk Management, Business Performances*

### 1 INTRODUCTION

Outsourcing at the present time has become a trend among companies around the world as there are a lot of benefits that can be gained as well as some risks. Consequently the companies applying outsourcing to support all of the company's activities must realize the risks or constraints of applying it. The company, thus, greatly requires risk management on IT outsourcing which can be a factor of the success of the project dealt by outsourcing (Indrajit dan Djokopranoto. 2004). Risk Management is quite important to minimize the risks during the project to get the maximum result. There are some possible risks that might appear, namely (1) the expected goals will not fully achieved; (2) the failure to achieve some of the expected goals (3) the slow achievement of the goals (Indrajit dan Djokopranoto. 2004).

Management risk is very important to reduce the possibly appeared risks in the project itself, so that satisfactory results can be achieved. Risk management should be applied in the IT outsourcing because it will analyze the problems appeared in IT outsourcing. My objective is, therefore, to analyze how companies or organizations apply the risk management in the practice of IT outsourcing. Risk management of IT outsourcing should be prepared from the beginning of the project, to achieve the expected results.

## 2 RESEARCH METHODOLOGY

### 2.1 Risk Management in IT Outsourcing

We, in advance, have to know what the purpose of IT outsourcing is. IT outsourcing is the act of transferring all or some of the IT decision related to the process of business, providing services to external, transferring rights, as well as internal activities. Providers will develop, control and manage all of the activities, working standard set in the contract (Balakrishnan, S. D. a. B. 2006). In IT outsourcing, it is important to manage the activities correctly and effectively so that companies must select the right partner to guarantee that the work can run successfully. Good outsourcing service providers will be able to increase the affectivity of corporate partners yet poor service providers can also increase the risk that might occur in the future (NISER. 2003). Now the question for companies that use the service of IT outsourcing is, how to guarantee the performance of outsourcing itself in favor of companies to guarantee that the project will run successfully. The answer is that the company must apply the risk management practices in the IT outsourcing project. Risk management is the process of analyzing, identifying, controlling and managing the problems and risks that will occur during the project. Organizations should conduct careful and deliberate risk management as it can substantially attenuate the level of risks of exposure (Jorgensen, J. 1996). According to ((FFIEC), F. F. I. E. C. 2004) outsourcing management has four steps consisting of risk assessment and definition of requirements, due diligence in choosing a service provider, contract negotiation, implementation and monitoring. Risk management is required from the early stages of process which aims to reduce the impact of risk that may appear or can prevent the risk of impacts to occur (Misra, R. B. 2004). To achieve satisfactory results from the risk management in IT outsourcing project, it should have a continuous systematic risk management.

### 2.2 Problem Statement

Information technology (IT) outsourcing is about technology, contracting out services to third parties, but involves more than the definition of new contractual arrangements.

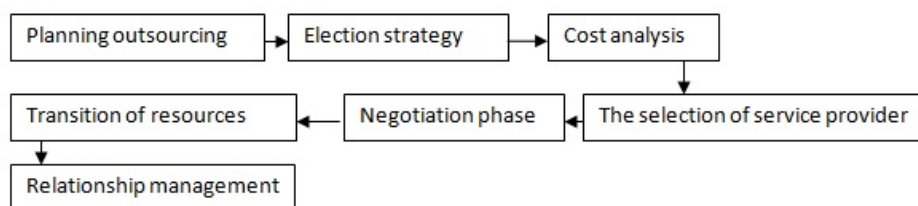

Figure 1: Step implementation of outsourcing (Indrajit & Djokopranoto 2004, p.14)

Many companies that use outsourcing services to help or make IT project itself experience common problems that arise in the company such as not achieving the goal, inappropriate working standards, outsourcing standards that do not meet the criteria of the company, the leakage of companys information security. Some problems appear in the companies that do not apply the risk management that is proven to be effective to make the project run well,

which a project is created by the outsourcing. There are many advantages of risk management of IT outsourcing projects for the company and for the project itself.

## **2.3 Research Objectives**

The purpose of this research for the companies that use IT outsourcing services is to make the project emphasizing the importance of risk management to guarantee the success of the project conducted by IT company which applies outsourcing man-power, so that the goal can be successfully achieved and it will not make any mistakes causing unexpected failure leading the company into a loss.

## **2.4 Methodology**

### **2.4.1 Types of Research**

The methodology that will be applied in this research is the method of interview (Sandjaja, B dan Heriyanto, A. 2006). The interview will be conducted on those who are competent in their field, the materials in the question relate to the practice of outsourcing that will be executed by their company, the reason they hire outsourcing, benefits for the company itself and the applied method for outsourcing so that the goals will be successfully achieved.

### **2.4.2 Types of Data**

Data that will be used in this research are qualitative data. Qualitative data are those that come from people who have capability related to the required data in the research. Data from the interview conducted on the practice of outsourcing will be applied by their company, the reason they hire outsourcing, benefits for the company itself and the method which is applied to outsourcing

### **2.4.3 Sources of Data**

The used data are:

1. Primary Data, that is the data obtained through direct observation and interviews on the capable persons or companies (Firdaus, M.A. 2012). Data results from the interview are about the practice of outsourcing that will be performed by the company, the reason of the companies to hire outsourcing, advantages for the company and the method applied to the outsourcing.
2. Secondary Data, that is the data obtained through publications of the company (Firdaus, M.A. 2012). Covering all required information of the company. They can be obtained from the internet through the companys web.

### **2.4.4 Method of data collection**

In-depth interviews are applied to obtain more accurate and detailed data results and related to the questions that have been prepared associated with the outsourcing practices applied by the company. So that we get more clear, complete and accurate information on the questions we prepared. The types of interviews to be applied are free guided interview.

Free interview guided is a combination of free interviews and guided interviews, so that the interviewer uses guidance that can direction of question-answer, however the implementation is relaxed and it does not seem too serious in order to make the respondents not rigid in answering the interview questions (Messrs & Heriyanto 2006, p .148).

### 2.4.5 Data Analysis

The data will be analyzed by cross-checking the relations of the obtained data one another. From the interviews, it could be found competent person of the company, we can describe the results of the interview properly. The effect of the previous stage is that we can conclude the results.

## 3 RESULTS AND DISCUSSION

The methodology that will be applied in this research is the method of interview. So that we get more clear, complete and accurate information on the questions we prepared. The interview will be conducted on those who are competent in their field. The types of interviews to be applied are free guided interview. Free interview guided is a combination of free interviews and guided interview. Data that will be used in this research are qualitative data. The used data are: Primary Data and Secondary Data, that is the data obtained through publications of the company.

Risk Management for IT outsourcing is very important for its success. It is one of the critical success factors for itself. It is expected that by conducting the research on risk management for IT outsourcing can be the input for the company, any steps that should be prepared before the outsourcing practice to guarantee that activities of the company in achieving its goals (Strategic intent for IT Outsourcing. 1998), (APICS. (2003).

## 4 CONCLUSION

From the research we have done, we get the steps in risk management in IT outsourcing, according to sources that can be trusted and can be justified on the level of proficiency of the company. From these results it can be used as a constructive input to the needs or even be a consideration for the company that will organize the activities in IT outsourcing company. So that it can minimize the unexpected situation and the achievement of expected goals of the company.

### References

- APICS, (2003), *Managing the Risks of Outsourcing: A Survey of Current Practices and Their Effectiveness*.
- Balakrishnan, S. D. a. B., (2006), Risks, Benefits and Challenges in Global IT Outsourcing Perspectives and Practices. *Global Information Management*, Vol 14, No 3, pp 39-69.
- Firdaus, M.A., (2012), *Metode Penelitian*. Tangerang Selatan: Jelajah Nusa.
- (FFIEC), F. F. I. E. C., (2004), *Outsourcing Technology Services*.
- Indrajit, Djokopranoto, (2004), *Proses Bisnis Outsourcing*, 2nd ed. Jakarta: PT. Grasindo.



Jorgensen, J., (1996), Managing the Risks of Outsourced IT. *The Internal Auditor*, Vol 53, No 6, p. 54.

NISER,(2003), *ICT Survey for Malaysia 2001/2002*.

Misra, R. B.,(2004), Global IT Outsourcing: Metrics for Success of all Parties. *Information Technology Cases and Applications*, Vol 6, No 3, pp 21-34.

Sandjaja, B., Heriyanto, A.,(2006), *Panduan Penelitian*, Jakarta: Prestasi Pustakarya.

*Strategic intent for IT Outsourcing*, (1998), Summer 3,4 Academic Research Library.

# Systems Engineering: Why is it Important ?

**Beni Suranto**

Department of Informatics, Faculty of Industrial Engineering  
Universitas Islam Indonesia  
e-mail:beni.suranto@uii.ac.id

## ***Abstract***

*This paper is concerning about systems engineering which has strong relationship with software engineering field both in the concepts and in the practical aspects. This paper starts with the explanation about some important concepts in systems engineering such as definitions, characteristics, and real practice examples. The next part of this paper will discuss about the need of systems engineering and the professional competencies of systems engineers. The last part of this paper will discuss about the benefits of teaching systems engineering to software engineering students.*

**Keywords :** *competencies, software engineering, systems engineering*

## **1 SYSTEMS ENGINEERING CONCEPT**

INCOSE (2006) stated three representative definitions for systems engineering. The first definition defines systems engineering as a profession, the second definition defines systems engineering as a process, and the last one defines systems engineering as a perspective. From those definitions, there are some important keywords to define what systems engineering is : wholeness, iterative, interdisciplinary, and sociotechnical.

To understand the concept of systems engineering we must first understand systems thinking. Systems thinking is the basis for the systems engineering perspective. It occurs through some enriching processes such as diagnosis, learning, dialog, and discovery that allow engineers to sense, model, and discuss about the real-world so they can have a better understanding to define and work with large or complex systems. Systems thinking can be considered as a unique perspective about the wholeness of systems (INCOSE, 2006). Engineers with a good systems thinking will be more aware of the wholeness aspect of systems and how all elements in the systems interrelate. Engineers with a good system thinking always know exactly how their systems can be integrated in the larger context of daily life. They also completely understand about their systems behaviors and how to effectively manage them.

Systems engineering is different from traditional engineering disciplines such as mechanical, computing & software, mining, electrical, petroleum, or aerospace. With the "system as a whole" perspective, systems engineering emphasis the systems total operation. Systems engineering concerns with not only engineering design but also external factors of the system

and the interactions between the system with the environment (Calvano, 2004). Also, its not only aware about the inside view but also the outside view of the system. Systems engineering can be understood as a concept that bridges all traditional engineering disciplines involved in a big, large, complex project. Furthermore, systems engineering inherent some important aspects of the project management concept that concern with the engineering effort in the project, setting the mission or objectives of the project, guiding the projects executions, and evaluating the projects results (Klatt, 2009). Some examples of complex systems required systems engineering in their development process are shown in Figure 1-4.



(Source: <http://tech4technology.com/wp-content/uploads/2012/08/mars-rover-curiosity-sky-crane-landing.jpg>)

Figure 1: NASA's Mars rover Curiosity



(Source: <http://media.treehugger.com/assets/images/2011/10/japan-nuclear-reactor-power-meltdown-earthquake-photo-04.jpg>)

Figure 2: Nuclear Power Plant

## 2 THE NEED OF SYSTEMS ENGINEERING

The aerospace and defence industries are two major fields where systems engineering is intensively used, but this concept are also used in many other fields. Rouse (2007) mentioned that every organization is complex and can be considered as a system. Systems engineering is a primary need for improving organization and is a powerful weapon to defeat the three



(Source: [http://www.thehindubusinessline.com/multimedia/dynamic/00767/BL29ASH1\\_767297f.jpg](http://www.thehindubusinessline.com/multimedia/dynamic/00767/BL29ASH1_767297f.jpg))

Figure 3: Car Manufacturing Plant

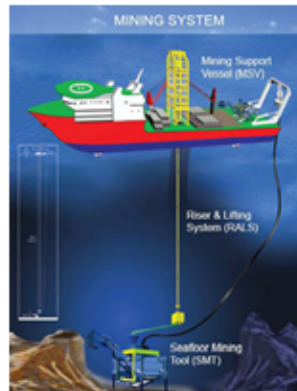

(Source: <http://www.marinelog.com-IMAGESMMVII/nautilus.jpg>)

Figure 4: Offshore Mining System

evils of engineering : complexity (underestimating the complexity of the project), lack of understanding (of the objectives of the project, the relationships within elements of the system, solutions of problems occurred during project life cycle) and communications problems (between engineers in the team, between organizations, within the project).

Systems engineering is becoming increasingly prevalent and important, especially in the projects that aim to produce large or complex systems. By applying appropriate systems engineering methodologies, the project team can effectively manage complexity and change during the system life cycle. The need for systems engineering is also driven by the fact that in the past 50 years the delivery time of a new product (from prototyping phase to market penetration phase) has dropped dramatically by more than a factor of four. This is shown in Figure 5.

An innovation is always affected by complexity and today's products (i.e. systems required to solve specific problems) have longer life cycle phases because most of them use the incre-

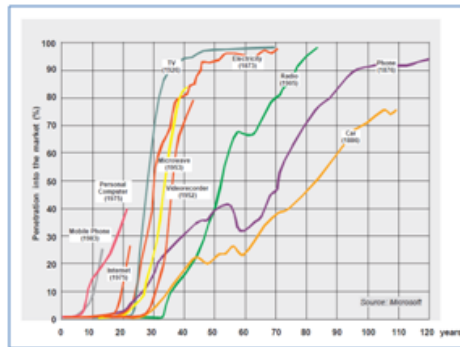

Figure 5: The delivery time of products in the last century (INCOSE, 2006)

mental improvement methods (Klatt, 2009). An appropriate systems engineering principles and processes becomes critical for the industries in order to establish and maintain their competitiveness level. By applying systems engineering principles and processes, the industries can quickly penetrate the market and deliver high quality products to their consumers in an efficient way. Systems engineering offers a rigorous process of requirements management that is very helpful for the project team to produce high quality requirements (i.e. well-defined, have adequate levels of traceability, consistent and verifiable). By producing high quality requirements, the project team can ensure that the design of the system accurately reflects the user requirements and the time-consuming changes or modifications to the system requirements in the later phases can be minimized. Furthermore, the project team can reduce the delivery time of the system. Figure 6 explains about how the system life cycle can be improved by applying the systems engineering method.

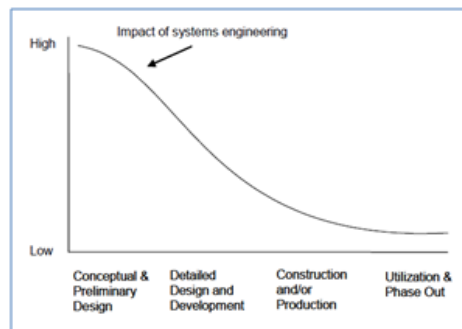

Figure 6: Impact of systems engineering method on the system life cycle (Calvano, 2004)

Beside reducing the delivery time, successful applications of systems engineering also allowing the industries or the project teams to gain significant life-cycle cost (LCC) savings. Well-defined and well-organized systems engineering processes can be very useful for the project team to save their money in some important phases, including the construction, operational use, system support, and the disposal phases of the system life cycle.

Honour (2004) conducted a survey to study about the impact of systems engineering

practices as perceived by INCOSE members and by NASA employees. The survey used more than 40 questions associated with some important aspects of organizations and complex system projects such as cost, schedule, risk, value, demographic, and so on and so forth. The survey investigated two things. The first one is about the overall impact of systems engineering practices on complex systems projects. Second, the survey investigated about the impact of software engineering practices on the cost of the projects. The result is shown in Figure 7 and Figure 8.

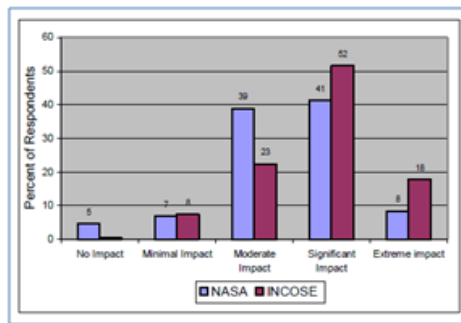

Figure 7: Overall impact of systems engineering on complex systems projects (Honour, 2004)

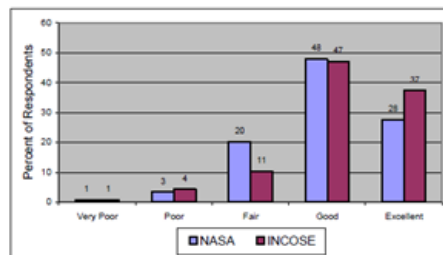

Figure 8: Impact of systems engineering practices on cost of complex systems projects (Honour, 2004)

### 3 COMPETENCIES AND SKILLS FOR SYSTEMS ENGINEERS

Kasser (2010) stated that a good systems engineer must have competencies in three areas:

1. Knowledge. A good systems engineer must have an adequate knowledge of systems engineering principles and processes and the application domain of the systems they develop.
2. Cognitive characteristics. A good systems engineers must be able to identifies, thinks and solves the problems during the system life cycle both in the conceptual and real-world domains.
3. Individual traits. A good systems engineers must be able to works wirk, communicates with, influences and leads other engineers in the project team.

Figure 9 shows more detail about three competencies areas aboved.

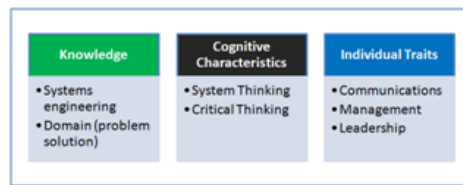

Figure 9: Three competencies areas of systems engineers (Kasser, 2010)

Ryschkewitsch and Schaible (2009) mentioned 11 personal characteristics of a good systems engineer:

1. Intellectual curiosity. A good systems engineer must be able and desire to learn new things. He/she must have strong perpetual learning spirit and always be motivated to encounter new ideas, problems, challenges, and technologies.
2. Ability to see the big picture. A good systems engineer must be capable to maintain a big-picture perspective during the project. He/she must have a complete understanding about his/her role in the project and the project itself.
3. Ability to make system-wide connections. A good systems engineer must understand the connections among all components of a system in his/her project.
4. Exceptional two-way communicator. A good system engineer must have very good communication skills (listen, talk, and write) in order to bridge the communications gaps on his/her team.
5. Strong team member and leader. A good systems engineer must be skilled both in leadership and management.
6. Comfortable with change. A good systems engineer always realize that during the project life cycle change is inevitable so he/she anticipate change and find the solution about how the project deal with the effects of the change in a proper way.
7. Comfortable with uncertainty. Systems engineers will always find uncertainties during the project. h. Proper paranoia. It means that a good systems engineer always expecting the best, but thinking about and planning for the worst.
8. Diverse technical skills. A good systems engineer must be has an adequate understanding of many technical disciplines.
9. Self confidence and decisiveness. A good systems engineers has a good self-confidence and undertands his/her strength and weaknesses.
10. Appreciate the value of process. A good systems engineer appreciates the value of process.

#### 4 THE BENEFITS OF TEACHING SYSTEMS ENGINEERING TO SOFTWARE ENGINEERING STUDENTS

In general, software engineering courses (e.g. programming methods, object-oriented development, requirement engineering, software testing, etc) mainly focus on techniques to develop software systems and less discuss about the softwares operational context. This situation has at least two negative consequences (Sommerville, 1998):

1. Some students have no understanding of the relationships between software and other components of large, complex systems. Many students do not appreciate other disciplined approaches required in the software development process because they are self-taught software developers.
2. Many graduates from software engineering courses have not enough understanding about the problems faced by engineers from other disciplines. They often difficult to communicate and make limited participations in the large and complex systems development process.

By learning about the systems engineering concept, students will get a better understanding of complex systems and real-world problems. For software engineering students, there are at least two positive benefits of integrating systems engineering in their courses (Sommerville, 1998):

1. By understanding the systems engineering concept, students can realize the potential of software engineering as an effective way to provide solutions of problems occurred in a complex systems. This will make they feel proud to be software engineers.
2. Systems engineering will make non-technical factors (human, social, economics, politics, etc) to be more real to students. It will show students that a programming solution is not always appropriate to solve a problem. With systems engineering, students will understand that the real systems strongly influenced by non-technical factors.

From the industry perspective, teaching systems engineering concept to software engineering students is very important since todays most industries in information technology area are unifying software engineering and systems engineering methods in their processes [13]. The industries unify software engineering and systems engineering methods to give them a great ability to tame the rapid changes of information technology. Also, experience indicates that the industries that combined software engineering and systems engineering methods found themselves far more suited to developing large and complex systems (Boehm, 2000).

One of the most popular products of software engineering development is the information system. The most challenging problem in information system analysis process is how the engineers effectively derive the requirements, especially in a complex, performance-critical, safety-critical, and expensive information systems. Systems engineering method is very useful for the engineers to help them to perform the analyze problems in complex systems. With systems engineering method, engineers working on a complex systems project will be able to effectively identify the fundamental parameters, develop credible alternate solutions, perform trade-off analyses, and select the best solutions (Osmundson, 2000). Clearly, software engineering students need systems engineering skills to be able to deal with complex systems development process.



## References

- Boehm, B.,(2000), Unifying software engineering and systems engineering. *Computer (Long Beach, Calif.)* (0018-9162), 33 (3), p. 114. DOI: 10.1109/2.825714.
- Calvano, Charles N.,(2004), Systems engineering in an age of complexity. *Systems engineering* (1098-1241), 7 (1), p. 25. DOI: 10.1002/sys.10054.
- Honour, E.C.,(2004), Understanding the Value of Systems Engineering, *Proceedings of the INCOSE International Symposium*, Toulouse, France.
- INCOSE, (2006), *Systems Engineering Handbook version 3*.
- Kasser, Joseph E., Frank, M, (2010), A Maturity Model for the Competency of Systems Engineers, *Proceedings of the 20th International Symposium of the INCOSE*, Chicago, IL. pp. 1-14.
- Klatt, KU.,(2009), Perspectives for process systems engineering–Personal views from academia and industry, *Computers & chemical engineering*, (0098-1354), 33 (3), p. 536.
- Osmundson, John S.,(2000), A systems engineering methodology for information systems. *Systems engineering* (1098-1241), 3 (2), p. 68. DOI: 10.1002/1520-6858(2000)3:2;68::AID-SYS2;3.0.CO;2-A.
- Rouse, William B., (2007), Complex engineered, organizational and natural systems Issues Underlying the Complexity of Systems and Fundamental Research Needed To Address These Issues. *Systems engineering* (1098-1241), 10 (3), p. 260. DOI: 10.1002/sys.20076.
- Ryschkewitsch, M, Schaible, D, Larson, W, (2009), The Art and Science of Systems Engineering, *National Aeronautics and Space Administration*.
- Sommerville, I., (1998), Systems engineering for software engineers. *Annals of software engineering* (1022-7091), 6, p. 111.

## Tsukamoto Method in Decision Support System for Realization of Credit on Cooperative

**Ginanjar Wiro Sasmito, Oman Somantri**

Prodi D4 Teknik Informatika, Politeknik Harapan Bersama  
e-mail:anjar.dosen@gmail.com, oman\_mantri@yahoo.com

### ***Abstract***

*In managing credit services, Cooperative in need of a system that can produce information that is more fast, precise, accurate, and relevant in order to improve the quality of service to customers as well as the performance of the employees. One way to strengthen the system of credit services business unit in Cooperative is to apply the method Tsukamoto Fuzzy Inference System (FIS). Tsukamoto FIS method is a computational framework that is based on fuzzy set theory, fuzzy rules in the form of IF - THEN, and fuzzy reasoning. To minimize errors in calculations, Tsukamoto FIS method to determine the actual credit application will be implemented in the Decision Support Systems. With the Decision Support System employees who handle credit services in Cooperative enough input data required by the systems, then the system will process these data by the method of Tsukamoto and will display the output a decision in accordance with the actual credit application existing provisions.*

**Keywords :** *Tsukamoto FIS, Decision Support System, Credit*

## **1 INTRODUCTION**

Cooperative is an autonomous association of persons who voluntarily join to meet needs and aspirations for economic, social and cultural separation of the same through-owned and democratically controlled (Hendrojogi, 1997). One function of the cooperative is to enhance the living standards of its members, increase production and realize a fair income and equitable prosperity (Kartasapoetra, G. et all, 2003). Furthermore, Indonesian cooperatives shall have and based on the values of self-help, self-responsible to themselves, democracy, equality, equity and solidarity. In carrying out its functions, the cooperative in Indonesia given the authority to manage the existing managerial system, one of which is to develop his own business unit. Likewise with Serba Guna Cooperative.

Serba Guna Cooperative is one of the cooperative located in the district of Brebes and has been established since 1996, according to the Decree of the Minister of Cooperatives No.: 10968a/BH/PAD/KWK.II/XII/96. In management for 18 years, Serba Guna Cooperative has had several business units, including: credit services, savings and loans, photocopy services and sales of stationery. However, from a variety of business units owned by the Serba

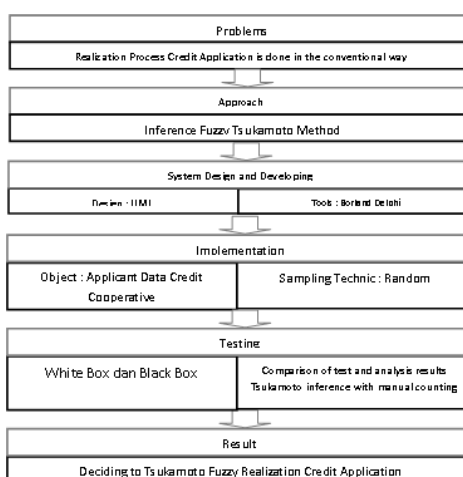

Figure 1: Frame Of Mind

Guna Cooperative, just credit business that can sustain the continuity of the other business units in the Serba Guna Cooperative.

In managing credit services, Cooperative in need of a system that can produce information that is more fast, precise, accurate, and relevant in order to improve the quality of service to customers as well as the performance of the employees. But the system is running on the credit services business unit in Cooperative sometime still very weak due to the processing of data and information that is recorded in the books so that the decision-making process takes a long time, the possibility of manipulation of data between prospective customers and employees in the loan portfolio as well as the difficulty manager make decisions for the realization of a credit application due to the cooperative task manager deals with many technical and operational activities for all cooperative efforts (Hendrojogi, 2002).

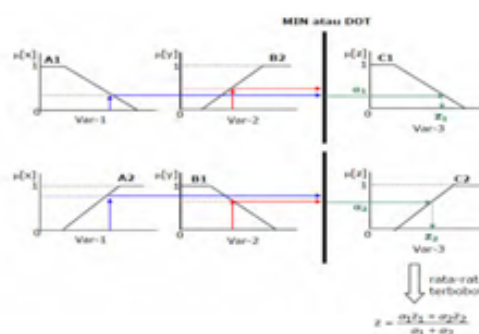

Figure 2: Tsukamoto Method Inference

One way to strengthen the system of credit services business unit in Cooperative is to apply the method Inference Tsukamoto Fuzzy System (FIS). According Kusumadewi & Hartati (2006) Tsukamoto FIS method is a computational framework that is based on fuzzy

set theory, fuzzy rules in the form of IF-THEN, and fuzzy reasoning. This method was chosen because each consequent to the rules in the form of IF-THEN represented by the fuzzy set membership functions are monotone. As a result, the output of each rule is given firmly based on , then the final result is obtained by using median centered.

To minimize errors in calculations, Tsukamoto FIS method to determine the actual credit application will be implemented in the Decision Support System. According Turban (2004) Decision Support System is a computer-based information system that combines models and data to provide support to decision makers in semi-structured problems solutions or dependency issues involving the user in depth.

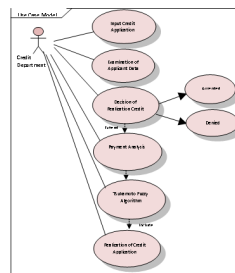

Figure 3: Use Case Diagram

Decision support system (DSS) could be used to simplify the existing procedures and improve decision-making. Several researchers have been applying decision support systems (DSS) approaches to some applications, such as: 1) Selection of Indonesian Workers (TKI) abroad (Ariani, 2013), 2) Bidik Misi Scholarships selection (Umami, 2014), etc. In this article author would like to apply DSS concept by using fuzzy in Credit cooperatives.

With the Decision Support System employees who handle credit services especially in Serba Guna Cooperative enough input data required by the system, then the system will process these data by the method of Tsukamoto and will display the output (output) a decision in accordance with the actual credit application existing provisions.

## 2 RESEARCH METHODOLOGY

### 2.1 Frame Of Mind

Frame Of Mind show in Figure 1.

### 2.2 Inference Fuzzy Tsukamoto System Method

In the Tsukamoto method, each consequent to the rules in the form of IF-Then shall be represented by a fuzzy set with the membership function is monotonous (Figure 3.2). As a result, the output result of each inference rule expressly given (crisp) based on -predicate (fire strength). The end result is obtained by using a weighted average. (Kusumadewi, 2003)

### 2.3 System Design

According Ambler (2005) Use Case is a diagram showing the relationship between actors and use cases. Use case used for the analysis and design of a system. Use case can describe

the interaction between the users of the system with the system itself, with gives a narrative of how the system used.(Fowler, 2004). Show in Figure 3.

## 2.4 Activity Diagram

Activity diagram is a diagram that illustrates the concept of data flow/control, structured action and well designed in a system.(Bock, 2003).Show in Figure 4.

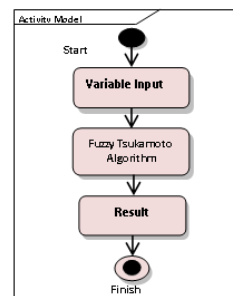

Figure 4: Activity Diagram

## 3 RESEARCH RESULT

### 3.1 Interface

According Kusnasriyanto (2003) Decision Support System Interface realization credit application created using Borland Delphi. Delphi is a programming language that has several advantages, including: the concept of open items, basic language PASCAL (Abdillah, 2009) is easy to learn, the result of a native compile to win 32.

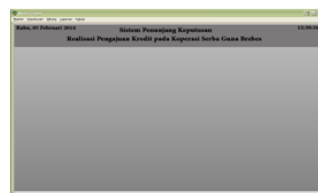

Figure 5. Main



Figure 6. Credit Request



Figure 7. Applicant Credit Guarantees



Figure 8. Decision Credit Application

### 3.2 Establishment of rules

Set of rules is one of the characteristics and conditions that must exist on the Fuzzy Inference System (FIS) (Ross, 2004). Fuzzy rules are created, using the input variables such as weight and condition guarantees nominal weights filing. The variable output of the actual decision whether a credit application is accepted or rejected. Format rule set as follows :

[R<sub>i</sub>] IF  $x_{ij}$  is  $A_{ij}$  °...°  $x_{in}$  is  $A_{in}$  THEN  $z_i$  is  $B_i$ .

explanation :

- ✓ R<sub>i</sub> : rules of fuzzy number- $i$  ( $i=1...m$ )
- ✓  $x_{ij}$  : weight bail conditions and nominal weights filing all relevant with rules number- $i$
- ✓  $A_{ij}$  : fuzzy sets for variable weight value  $j$  subjects relevant to number  $i$  rule
- ✓ ° : operators that can be used (AND or OR)
- ✓  $n$  : The value of collateral relevant to the rules number - $i$
- ✓  $B_i$  : Fuzzy sets for variable credit application decisions on rules number - $i$

The formation of this rule can be made by credit section by considering the condition of collateral in applying for a loan.

### 3.3 Composition Rules and Decision Credit Realization

Set of rules that have been compiled by the decision maker, will then be used as a reference for determining the actual credit application. Determination of the actual credit application will be obtained after the value of collateral provided and the nominal value of credit application. Furthermore, the composition made between the rules in order to find the value of  $\alpha$ - predicate or fire strength of each rule ( $\alpha_i$ ).  $\alpha$ -predicate value is highly dependent on the service used. In the AND operator, value given predikat "x1 is A1 and x2 is A2" is given as follows (Cox, E, 1995) :

$$\alpha_i = \mu_{A_1 \cap A_2} = \min(\mu_{A_1}(X_1), \mu_{A_2}(X_2))$$

On Operator OR,  $\alpha$  value predicate given by "X<sub>1</sub> is A<sub>1</sub> and X<sub>2</sub> is A<sub>2</sub>" given as follows :

$$\alpha_i = \mu_{A_1 \cup A_2} = \max(\mu_{A_1}(X_1), \mu_{A_2}(X_2)).$$

Having obtained the value of  $\alpha_i$ , then the next will be the process of calculating the value of each consequent of each rule ( $y_i$ ) in accordance with the membership functions are used. In the consequent "Decisions Denied", then the equation is based on Rejected  $\mu(y) = 1 - y$ , the value of  $y_i$  is:  $y_i = 1 - \alpha_i$

In the consequent "Decision Received", then the equation is based on be accepted ( $y$ ) =  $y$ , the value of  $y_i$  is:  $y_i = \alpha_i$ . After all consequent values obtained, then the value of  $y$  the end as the realization of the credit application decision value can be calculated :

$$y = \frac{\sum_{i=1}^n \alpha_i y_i}{\sum_{i=1}^n \alpha_i}$$

### 3.4 Decision Support System Testing Results

The software development life cycle (System Development Life Cycle: SDLC) one of a process that must be done is the testing process. Software testing is a technique used to test whether a generated software has met the needs of users or business processes or not. Testing is the process of executing a program to find errors before use by end-user (Pressman, 2005).

Tests carried out on this system using the Black Box which checks whether the system can run properly as expected. The test techniques used in black box testing in this system, namely using sample testing techniques. The test is performed on the data input process. In addition, the method of testing UAT (User Acceptance Test) where the testing was conducted by lending or direct users to check if the system can run properly as expected by the user. This test involves real data obtained directly without regard to the internal details of the system.

## 4 CONCLUSION

Based on the research that has been done, then some conclusions can be drawn as follows:

1. Tsukamoto Fuzzy decision support system for the realization of this credit application can be implemented in cooperative with variables that have been obtained from the cooperative.
2. Tsukamoto Fuzzy decision support system for the realization of this credit application can provide a decision to reduce errors in calculation.
3. With the decision support system that handles part of credit services no longer depend entirely on the manager as decision makers.
4. This decision support system can help managers analyze the realization of the credit application.
5. From the tests concluded that the interpretation of the results of the decision support system was built considered successful because of the ease and convenience in using this system.

## References

- Abdillah, L.A. (2009). *Pemrograman III (Delphi Database)* Edisi 4. Palembang: Pusat Penerbitan dan Percetakan Universitas Bina Darma.
- Ariani, A., Abdillah, L.A., Syakti, F. (2013). Sistem Pendukung Keputusan Kelayakan TKI to luar negeri menggunakan FMADM, *Jurnal Sistem Informasi (SISFO)*, vol. 4, pp. 336-343, September 2013.
- Aghataher, R. dkk. (2008). A Fuzzy-AHP Decision Support System for Evaluation of Cities Vulnerability Against Earthquakes. *World Applied Sciences Journal 3 (Supple 1)*: 66-72, 2008. ISSN 1818-4952. IDOSI Publications, 2008.
- Ambler, Scott. W. (2005). *The Elements of UML 2.0 Style*. Cambridge University Press.
- Bock, Conrad. (2003). UML 2 Activity and Action Models. *Journal of Object Technology* 2.

- Cebeci, Ufuk. (2009). Fuzzy AHP-based decision support system for selecting ERP systems in textile industry by using balanced scorecard. *Expert System With Applications* 36 (2009) 8900-8909.
- Cox, E. (1995). *Fuzzy Logic for Business and Industry*. Charles River Media inc. Rockland, Massachusetts.
- Firmansyah, I., Utami, Silvia F. (2013). Tsukamoto Fuzzy Logic Application in Production Planning at PT. Kimia Farma (Persero) Tbk. Plant Bandung Indonesia. *Proceedings The 2nd International Conference On Global Optimization and Its Applications 2013 (ICo-GOIA2013)*.
- Fowler, Martin. (2004). *UML Distilled (Third Edition)*. Addison-Wesley.
- G. Kartasapoetra, Ir.A.G. Kartasapoetra, Drs. Bambang S, Drs.A. Setiady. (2003). *Koperasi Indonesia. PT Bina Adiaksara & PT Rineka Cipta*, Jakarta, hlm., 8,9,27,31.
- Hendrojogi.(1997). *Koperasi: Azas-Azas, Teori & Praktek*. PT RajaGrafindo Persada, Jakarta, hlm. 46.
- Hendrojogi.(2002). *Koperasi (Asas-asas, Teori dan Praktek*, PT Raja Grafindo Persada, Jakarta.
- Ihsan, A., Shoim, A. (2012). Penentuan Nominal Beasiswa yang Diterima Siswa dengan Metode Logika Fuzzy Tsukamoto. *Jurnal Ilmiah Ilmu Komputer*, Vol. 8 No. 2 Maret 2012: 167-173. Universitas Pelita Harapan.
- Kusnassriyanto. (2003). *Belajar Pemrograman Delphi*. Modula. Bandung.
- Kusumadewi, Sri. (2003). *Artificial Intelligence (Teknik & Aplikasinya)*. Jogjakarta:Graha Ilmu
- Kusumadewi, Sri., Hartati, Sri. (2006). *Neuro Fuzzy-Integrasi Sistem Fuzzy dan Jaringan Syaraf*. Yogyakarta: Graha Ilmu.
- Pressman, Roger S. (2005). *Software Engineering : A Practitioners Approach*. Mc. Graw Hill
- Ross, T.J. (2004). *Fuzzy Logic With Engineering Applications*. Edisi Ke-2. John Wiley & Sons Inc. Inggris
- Saleh, Ahmed Abou Elfetouh ,dkk. (2011). A Fuzzy Decision Support System for Management of Breast Cancer. *International Journal of Advanced Computer Science and Applications (IJACSA)*.Vol. 2, No.3, March 2011.
- Thamrin, Fenoel.(2012). *Studi Inferensi Fuzzy Tsukamoto untuk Penentuan Faktor Pembebanan Trafo PLN*. Magister Sistem Informasi Universitas Diponegoro. Semarang.
- Turban, Efraim et.all.(2004). *Introduction To Information Technology*. Wiley 3 Edition.
- Umami, P., Abdillah, L.A., Yadi, I.Z. (2014). Sistem penunjang Keputusan pemberian beasiswa Bidik Misi, *Konferensi Nasional Sistem Informasi (KNSI)*, STMIK Dipanegara Makassar, Sulawesi Selatan, 2014.



## Prediction of Understanding of Students Under Course Lecturer Professional Use Neural Network Backpropagation

T.Henny Febriana Harumy, Darmeli Nasution,  
Yuyun Yusnida Lase

Universitas Pembangunan Pancabudi Medan  
e-mail:hennyharumy@hotmail.com, darmelinasution@gmail.com, yylase80@gmail.com

### *Abstract*

*The process of learning is one of the activities in a college / institution in the intellectual life of the nation. That role is inseparable from professional teachers. In the process of learning the necessity of a two-way relationship between students and professional teachers. This meant that there was good cooperation during the learning process takes place. Evaluations are conducted by the university / institution for teaching and learning process is necessary to end the semester. It is intended that there is an assessment of the students and faculty. For these students aimed at assessing the level of understanding and acceptance of the subjects taught and the teachers in order to assess the extent to which teachers can distribute knowledge on subjects that for 1 (one) semester. So that the university / institution can provide a fair decision. In prediction level of students' understanding of the course to implement Neural Network using backpropagation algorithm. This method was chosen because it is able to determine the level of students' understanding of the course is based on input from questionnaires given. The study was conducted in two ways, namely training and testing. Data will be divided into two parts, the first data for the training process and second data for the testing process. The training process aims to identify or search for goals that are expected to use a lot of patterns, which a will be able to produce the best patterns to train the data. After reaching the goal of training is based on the best pattern will be tested with new data to look at the accuracy of the target by using Matlab 6.1. Based on test results using Matlab 6.1 software can speed up the process of predicting students' understanding of the course is based on faculty at the University Pembangunan Pancabudi of Medan.*

**Keywords :** *Neural Network, Predicting, Backpropagation*

## 1 INTRODUCTION

Private colleges Pancabudi Development University of Medan has not implemented a system of determining the level of students' understanding of the course is based on professional teaching force. The process of learning is one of the activities in a college / institution in the

intellectual life of the nation. That role is inseparable from professional teachers. Predictions in the context of computing is one of the mathematical activity. This prediction has been done many years before the control computer, using tools such as calculators count. Prediction of students' understanding of the course is based on professional teaching staff can help the universities / institutions in making policies on the future of professional teaching staff.

To determine the level of students' understanding of the course is done by assessing (scoring) through questionnaires. Questionnaires were administered to represent the entire process of assessing the level of understanding of students on the course. Having obtained the target or desired goal of the assessment is carried determination (determination) for the level of students' understanding of the course by professional teachers.

Artificial Neural Networks is one of the information processing system that is designed to mimic the way the human brain works in resolving a problem with the process of learning through weight changes sinapsisnya. There are many techniques that can be used for the implementation of Artificial Neural Networks one of them is Backpropagation. Neural network using backpropagation algorithm has been widely used to solve some of the problems one prediction problem. In a previous study in the journal entitled Application of Neural Networks to Predict Unemployment in East Kalimantan Using Learning Algorithms Backpropogation (Adrijasa MF et al, 2009).

Based on the description of the background of the above problems, then that becomes a problem formulation are: 1) How to determine the parameters of the level of students' understanding of the course is based on professional teaching staff with backpropogation algorithm?, 2) How is the implementation of Artificial Neural Networks to determine the level of students' understanding of the course is based on professional teaching staff at the University of Development Pancabudi Medan?, and 3) How to apply Artificial Neural Networks to the criteria for the level of students' understanding of the course is based on professional teaching force?

The purpose of this study are: 1) Determine the criteria for determining the level of students' understanding of the course is based on professional teaching staff, 2) Implementation of Neural Networks for the determination of the level of students' understanding of the course is based on professional teaching staff for students of University Development Pancabudi field using backpropagation method, and 3) Test the backpropagation algorithm accuracy in determining the level of students' understanding of the course is based on professional teaching staff.

The benefits of this research are: 1) Can help the process of determining the level of students' understanding of the course is based on professional teaching staff, and 2) Can help colleges / institutions to determine the level of students' understanding of the subjects taught by the professional teaching staff.

## 2 RESEARCHMETHODOLOGY

### 2.1 Artificial Neural Networks

Artificial Neural Network (ANN) is one of the artificial representation of the human brain that is always trying to simulate the learning process of the human brain (Aprijani and Sufandi, 2011; Lai, 2006), while Li and Liu (2006); Warsito, et.al (2008), modeling the ANN as a system with inputs and outputs based on neural Biology. Several studies in various fields using methods of problem solving among the Traveling Salesman JST (Puspitorini, 2008).

KUESIONER EVALUASI PERKULIAHAN OLEH MAHASISWA						
Nama Kelas: _____						
Semester: _____						
Dosen Pengajar: _____						
Jurusan/Program Studi: _____						
Beri tanda silang (X) pada pilihan yang sesuai.						
No.	Uraian	Skor				
		1	2	3	4	5
1	1. Pada awal perkuliahan dosen menyajikan tentang kemampuan yang didapatkan mahasiswa setelah mengikuti perkuliahan ini.					
2	2. Pada awal perkuliahan dosen menjelaskan dengan baik tentang pokok-pokok perkuliahan dan metode pembelajaran.					
3	3. Pada awal perkuliahan dosen menjelaskan dengan baik tentang sistem penitisan dan alat-alatnya.					
4	4. Pada awal kuliah kerja dan atau literatur dijelaskan dengan baik.					
5	5. Pada awal kuliah yang digunakan untuk proses pembelajaran maka kuliah yang diberikan disampaikan sangat jelas oleh dosen.					
6	6. Dosen menggunakan media perkuliahan dengan baik.					
7	7. Dosen menjelaskan materi dan penerapannya.					
8	8. Pada awal kuliah kerja dan atau literatur mahasiswa yang memahami kuliah.					
9	9. Pada awal perkuliahan banyak menggunakan data cara pembelajaran maka kuliah ini.					
10	10. Menuntut kerja belajar dalam kelompok adalah cara efektif untuk belajar.					
11	11. Kegiatan media kuliah ini secara keseluruhan, secara umum, sangat baik.					
12	12. Dosen selalu memberi tugas setiap akhir pokok bahasan.					

Figure 1: The list of questionnaire question

Problem solving pattern recognition (Hidayatno et al, 2008).

Backpropagation training algorithm to network with one hidden screen (with a binary sigmoid activation function) is (Maru'ao, 2010): Step 0: Initialize all weights to small random numbers.

Step 1: If the termination condition is not met, do steps 2-8.

Step 2: For each pair of training data, perform steps 3-8.

Step 3: Step 3 (steps 3-5 are phase 1).

Each input unit receives the signal and forwards it to the hidden unit thereon.

Step 4: Calculate all the outputs in the hidden units  $z_j(j = 1, 2...p)$

$$Z_{net_j} = V_{jo} + \sum_n^{i=1} Z_j = f(Z_{net_j}) = \frac{1}{1 + exp^{-z_{net_j}}}$$

Step 5: Calculate all network output in units of output  $y_k(k = 1, 2, \dots, m)$ :

$$Y_{net_k} = W_{ko} + \sum_{j=1}^p Z_j W_{kj}$$

Recalculating accordance with the activation function:  $Y_k = f(Y_{net_k})$

$$Z_j = \frac{1}{1 + exp^{-y_{net_k}}}$$

Step 6: (steps 6-7 is a phase 2)

Calculate the factor  $\delta$  output unit based on the error in each unit of output  $y_k(k = 1, 2, \dots, m)\delta_k = (t_k - y_k)f(y_{net_k}) = (t_k - y_k)y_k(1 - y_k)t_k = target$

$\delta_k$  an error output unit that will be used in the weight changes underneath the screen. Calculate the rate of change in weight  $w_{kj}$  with  $\alpha$  understanding  $\Delta W_{kj} = \alpha \delta_k z_j, k = 1, 2, \dots, m, j = 0, 1, \dots, p$

Step 7: Calculate the factor hidden units based on the error in each hidden unit  $z_j(j = 1, 2, \dots, p)\delta_{net_j} = \sum_{k=1}^m \delta_k W_{kj}$

Factor  $\delta$  hidden units.

$$\delta_j = \delta_{net_j} f(Z_{net_j}) = \delta_{net_j} Z_j (1 - Z_j)$$

Calculate the weight change rate  $\Delta V_{ji}$ .

$$\Delta V_{ji} = \alpha \delta_j x_i, k = 1, 2, \dots, p, i = 0, 1, \dots, n$$

Table 1: The list of criteria

No	Kriteria	Variabel	Keterangan	Bobot
1	Pembelajaran	A	Sangat Setuju Setuju Moderat Tidak Setuju Sangat Tidak	1 0,8 0,6 0,4 0,2
2	Keterampilan (Skills)	B	Sangat Setuju Setuju Moderat Tidak Setuju Sangat Tidak	1 0,8 0,6 0,4 0,2
3	Penilaian dan Beban Kerja	C	Sangat Setuju Setuju Moderat Tidak Setuju Sangat Tidak	1 0,8 0,6 0,4 0,2
4	Bimbingan dan Konseling	D	Sangat Setuju Setuju Moderat Tidak Setuju Sangat Tidak	1 0,8 0,6 0,4 0,2
5	Sumber Pembelajaran	E	Sangat Setuju Setuju Moderat Tidak Setuju Sangat Tidak	1 0,8 0,6 0,4 0,2
6	Standard dan Target	F	Sangat Setuju Setuju Moderat Tidak Setuju Sangat Tidak	1 0,8 0,6 0,4 0,2

Step 8: Calculate the weight of all the changes. Weight change line leading to the unit output,

$$ieW_{kj}(new) = W_{kj}(old) + \Delta W_{kj}$$

$$k = 1, 2, \dots, m, j = 0, 1, \dots, pn$$

Weight change line leading to the hidden units, namely:

$$V_{ji}(new) = V_{ji}(old) + \Delta V_{ji}$$

$$j = 1, 2, \dots, p, i = 0, 1, \dots, n$$

## 2.2 Sum Square Error and Root Mean Square

Error error at the output of the network is the difference between the actual output with the desired output. The resulting difference between the two is usually determined by calculated using an equation. Sum Square Error (SSE) is calculated as follows:

1. Calculate the neural network output to the first input.
2. Calculate the difference between the neural network output and the desired target value for each output.

3. Multiply each output then count entirely

### 3 RESULTS AND DISCUSSION

#### 3.1 Stage Data Collection on document

In this study, a system of pattern recognition and prediction of students' understanding of the course is based on professional teaching force. Data were obtained from questionnaires distributed to students grouped by subjects who diampuh a professional teaching force. The format of a questionnaire given to students in the form of questions 30 questions with each question represents the study variables. The variable-variable penelitian are learning, skills (Skill), and workload assessment, guidance and counseling, learning resources and standards and targets. Students enough to give a score of 1 = Strongly Disagree, 2 = Disagree, 3 = moderate, 4 = Agree, 5 = Strongly Agree, such as the following format:

The charging process is done by taking a sample of some of the classes are categorized by subjects who diampuh by professional workforce. The list of criteria to determine the prediction of students' understanding of the course are as follows:

#### 3.2 Determining the Best Pattern

Training and testing were performed multiple times with different parameters to get the best results with Matlab 6.1 software application Neural Network method in determining the best pattern for the level of students' understanding of the course is based on professional teaching staff has a 3 part process, namely:

1. The process of data input and the target includes inputting learning, skills (Skill), and workload assessment, guidance and counseling, learning resources and standards and targets .. As for the target is the level of students' understanding of the course
2. The process of determining the results of the processed data includes the data conversion process into a predetermined weight, calculate the weight value into stages backpropagation.
3. The results of the process of determining the data processed with Matlab 6.1 software application will be used to predict the level of student understanding terhadapap subjects by comparing the value of the minimum error.

From a series of experiments performed using Matlab 6.1 software application with a model 6-50-1, 6-75-1 models, the model 6-100-1, 6-50-75-1 models and models 6-75-100- 1 obtained the best architectural pattern in the model parameters 6-50-1 with the following attributes:

Activation function to Hidden Layer: Tansig

Activation function to Output Layer: Logsig

Type Training: Traingd

Number of Hidden Layer Neurons: 50

Learning rate: 0.1

Error Limit Maximum: 0,001

Show Limits: 1000

Limit Maximum Epoch: 5000000

Table 2: Comparison of Each Model Epoch and MSE any architectural models

	6-50-1	6-75-1	6-100-1	6-50-75-1	6-75-100-1
<b>Epochs</b>	166828	> 2000000	38820	25145	19255
<b>MSE</b>	0,0009991940	Tidak Terdefenisi	0,0009995025	0,0009997820	0,0009993985

Table 3: Data Categorization Prediction

No	Keterangan	Error Minimum
1	Paham	0,0000 0,0010
2	Tidak paham	0,0011 - 0,0100

Momentum: 0.8

Of the parameters used to model architectural epochs 6-50-1 with 0.0009991940 MSE 166 828 and shown in Figure 2.

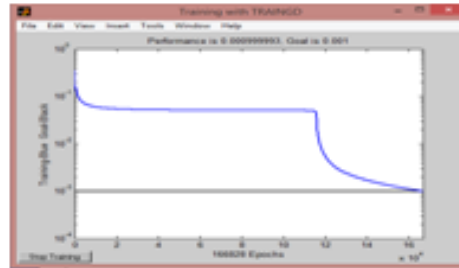

Figure 2: 6-50-1 architecture Achieve Goal

The data comparison of each model can be seen in the table below 5:19 this:

### 3.3 Prediction Level Student Understanding of the Course

The last stage is the prediction of student understanding of the subjects that diabawakan by professional teachers. This stage is done by comparing the value of the minimum error of the results obtained. With 6-50-1 architecture model, the data would be predicted to see how accurate the model is able to recognize the data. The desired results of this final stage is to get the minimum error value for the prediction of architectural patterns. The results are as follows:

1. Categorization understand and do not understand
2. Categorization understand is determined by the minimum error rate where familiar with weights 1 and are not familiar with weights 0
3. Categorization minimum error for prediction understand and do not understand the data can be seen in Table 3:

Table 4: Examples of writing table

Prediksi 6-50-1		Prediksi		Ket
No	NIM	Data Real	JST	Hasil
1	2.012E+11	1	0,00092	Benar
2	2.012E+11	0	0,00033	Benar
3	2.012E+11	0	0,00036	Benar
40	2.013E+11	1	0,00056	Benar
41	2.013E+11	1	0,00032	Benar
42	2.013E+11	1	0,00056	Benar
43	2.013E+11	1	0,0076	Salah
44	2.013E+11	1	0,0093	Salah
45	2.013E+11	1	0,0076	Salah
46	2.013E+11	1	0,0056	Salah
47	2.013E+11	1	0,0373	Benar
48	2.013E+11	1	0,00056	Benar
49	2.013E+11	1	0,0387	Benar

The data would be predicted to see level can be seen in table 4 below. Table 4 Results Prediction Model 6-50-1. By using 6-50-1 architecture model prediction results obtained 87.75%. In other words, this model is good enough to predict the level of students' understanding of the subject.

#### 4 CONCLUSION

Based on the results and analysis of the previous chapter, the authors can conclude as follows:

1. Adding lots of hidden layer during training and testing, not a maximum results. To 5-designed architectural models, 6-50-75-1 is a model that has the largest MSE is 0.028540763
2. After the experiment in the process of training and testing of the system is done using Matlab 6.1 software application. Neural Network Model used is 6-50-1, 6-75-1 models, the model 6-100-1, 6-50-75-1 models and models 6-75-100-1, can be obtained good results with a view MSE smallest and fastest epochs is 6-50-1.
3. With 6-50-1 architecture model, can perform a prediction of students' understanding of the subject by showing the performance above 92%

#### References

- Arif Jumarwanto A, et al. (2009), Aplikasi Jaringan Saraf Tiruan Backpropagation Untuk Memprediksi Penyakit Tht Di Rumah Sakit Mardi Rahayu Kudus, *Jurnal Teknik Elektro* Vol. 1 No.1, Kudus.
- Anwar. (2011), Penerapan Algoritma jaringan syaraf tiruan backpropogation dalam memprediksi tingkat suku bunga bank, *Jurnal saintikom STMIK triguna dharma*, Medan.
- Anike. M, et al. (2012), Pengembangan Sistem Jaringan Syaraf Tiruan Dalam Memprediksi Jumlah Dokter Keluarga Menggunakan Backpropagation (Studi Kasus: Regional X Ca-

- bang Palu), *Jurnal Seminar Nasional Teknologi Informasi dan Komunikasi 2012 (SENTIKA)* Atma Jaya Yogyakarta.
- Dahria, M. (2008), Kecerdasan buatan ( Artificial Inteligent ), *Jurnal saintikom*, vol 5 Jakarta.
- Devi, et al. (2012), ANN Approach for Weather Prediction using Back Propagation, *International Journal of Engineering Trends and Technology- Volume 3 Issue1* Department Of Computer Science and Engineering, KLCE, Vaddeswaram, Guntur Dt.-522502, Andhra Pradesh, India.
- Gunawan, et al. (2009), Penerapan Algoritma Backpropagation Untuk Klasifikasi Musik Dengan Solo Instrumen. *Aplikasi Teknologi Informasi (SNATI 2009)* ISSN:1907-5022 Yogyakarta.
- Hidayat, M.M, et al. (2013), Analisa Prediksi DO Mahasiswa Dalam Educational Data Mining Menggunakan Jaringan Syaraf Tiruan. *Jurnal IPTEK*, Volume 17 No.2
- Indrawaty, Y, et al. 2012, Implementasi Model Backpropogation Dalam Mengenal Pola Gambar Untuk Mendiagnosa Penyakit Kulit. *Jurnal Informatika* No.1 Volume 3.
- M.F. Andrijasa dan Mistianingsih. (2010), Penerapan Jaringan Syaraf Tiruan Untuk Memprediksi Jumlah Pengangguran di Provinsi Kalimantan Timur Dengan Menggunakan Algoritma Pembelajaran Backpropagation. *Jurnal informatika mulawarman*, Kalimantan Timur.
- Maru'ao,D.O. (2010), *Neural Network Implementation in Foreign Exchange Kurs Prediction*. Faculty of Industrial Engineering, Gunadarma University jakarta.
- Matondang, Z.A. (2013), Jaringan Syaraf Tiruan Dengan Algoritma Backpropagation Untuk Penentuan Kelulusan Sidang Skripsi. *pelita Informatika Budi Darma*, Volume ISSN : 2301-9425.
- Mulyati, S. (2009), *Penerapan Fuzzy Inference System (FIS) Dengan Metode Mamdani Pada Sistem Prediksi Mahasiswa Berhenti Studi (DROP-OUT)*.
- I Putu Eka, N.K. (2012), Evaluasi Kinerja Jaringan Saraf Tiruan Pada Peramalan Konsumsi Listrik Kelompok Tarif Rumah Tangga. *Jurnal Matematika*, Volume 2 No 1, ISSN : 1693-1394
- Siang, J.J. (2009). *Jaringan Syaraf Tiruan & Pemrogramannya Menggunakan Matlab*. Penerbit ANDI. Yogyakarta.



# Performance Analysis of Multiple-Computer as Real Application Clusters (RAC) Based on Storage Area Network (SAN)

Iyoga Don Frima Tarigan, Dong-Seong Kim

School of Electronic Engineering  
Kumoh National Institute of Technology, South Korea  
e-mail: Iyoga.don@alumni.ui.ac.id, dskim@kumoh.ac.kr

## **Abstract**

*Real Application Cluster (RAC) is a method to design a network that is used in large scale database which can handle full service all year round. RAC allows the pooling Server nodes in parallel and improve the Performance of each Server to be faster. RAC runs in multiple-computers. RAC was implemented with the support of Storage Area Network. Storage Area Network (SAN) is a high-speed dedicated network consisting of Servers and Storage. In general, SAN is connected via Fibre Channel (FC), UTP cable was used in implementation. Storage Area Network (SAN) was applied in clustering blocks device for high availability. Each block device will backup each other. SAN primary goal is to handle the density of large amounts of data between servers and storage without reducing the bandwidth available on the LAN/WAN. The integration uses three computers (hardware), DRBD package and Management Console (MC). Based on the results obtained by testing the availability is 100%. While the Clustering Performance obtained is 100% (The SANs Performance 93.396%, The Main and Cluster Server Performance 29.4945%).*

**Keywords :** *Real Application Cluster, Server, multiple-computer, Storage area network, high Performance and high availability*

## **1 INTRODUCTION**

The needs and demand of the modern application era changed in the sense it is not only requires computing resources (processing power, memory or disk space), but also the ability to remain available to handle user requests service almost continuously all year (Hartman, 1999). The Needs and demand of today's research applications. This research depends on some materials including the performance of the client and server computers, data transfer speed (Read/Write), and compatibility of hardware and software (Buyya, 2009).

The design of the computer usage in relation to the Cluster Server is the servers capability to share the performance of a number of servers (multiple) in one process (Taylor, 2003). If single server was used, no guarantee the server will always active. Therefore, it takes a cluster

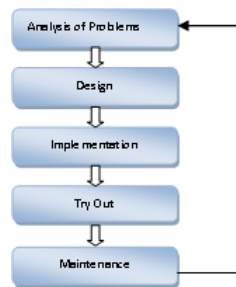

Figure 1: Flowchart of RAC on SAN

method to deal with such matters, so that when one server fails (down-time, offline, or failure) then the Server failover occurred in the set-up Cluster Server. Cluster servers are typically built with the same location. To integrate the SAN with Real Application Clusters (RAC) method based Storage Area Network (SAN). RAC works in high availability, which means the demand data, will be directly addressed by all servers in the node RAC to work together (Dyke, 2006).

RAC was designed to run on multiple-computer. Multiple-computer usually built by servers in the same location (Aizikowitz, 2005). RAC is the course to support the necessary method of SAN. SANs advantage is that every server can be accessed remotely with the best reliability. The program supported by the operating system will allow the Main and Cluster Server to share files (Hui, 2004). SAN is a very high speed networks, consists of Server and Storage. Separate and distinct from the corporate LAN or WAN, SAN primary purpose is to handle large amounts of data traffic between servers and storage equipment, without reducing the bandwidth available on the LAN or WAN. Usually connected via Fiber Channel, a technology is very high-speed data communications, making SANs a dedicated network that is platform-independent operating behind the Server. SAN consists of communications infrastructure, which provides physical connections, and layers of management, which control connection, storage element, and the computer system so as to produce a highly secure data transfer and reliable (Liu, 2009).

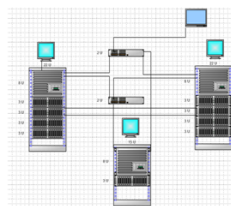

Figure 2: Layout of RAC on SAN

## 2 LITERATURE STUDY REAL APPLICATION CLUSTER (RAC) ON STORAGE AREA NETWORK (SAN)

In this section some basic theory used in the implementation of this system.

## 2.1 Multiple-Computer Cluster

Multiple-Computer Cluster is a collection of some servers which are connected to each other to form a single entity (Cluster). Computer cluster task is currently running to share the workload so as to increase the availability (Serrelis, 2007). Besides, Multiple-Computer Cluster are used to improve the performance when the event of disaster occurred (there is one server down/failure) then the failover will quickly run to turn a RAC where other Cluster Server will run the task of failover servers that have failed. Multiple-Computer Cluster is often also associated with a data center, because the data center consists of a set of Server and Storage. The data center is a facility that is used to place multiple servers or computer systems and data storage systems. Data centers can also be viewed as a data repository (data warehouse) that serves as a data management system starting from the collecting, processing, storage until the rediscovery of the data, and be able to also provide support in decision making (Thompson, 2003).

## 2.2 SAN

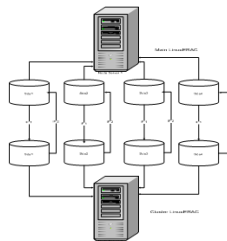

Figure 3: Configuration of RAC

Storage Area Network (SAN) is a very high speed networks in particular, consists of server and storage (Qui, 2005). Separate and distinct from the LAN/WAN Company, the main purpose is to handle traffic SAN large amounts of data between servers and storage equipment, without reducing the bandwidth available on the LAN/WAN (Calves, 2004). Usually connected via Fiber Channel, a very high-speed data communications technology, making SANs a dedicated network that is platform-independent operating behind the Server. SAN consists of communications infrastructure, which provides physical connections, and layers of management, which set up the connection, storage element, and the computer system so as to produce a highly secure data transfer and reliable (Chen, 2005). SAN consists of communications infrastructure, which provides physical connections, and layers of management, which set up the connection, storage element, and the computer system so as to produce a highly secure data transfer and reliable (Vasudeva, 2000).

## 2.3 RAC

RAC is a method for designing large-scale database that can handle 24-hour service (Greenwald, 2007). RAC is possible to bring together many servers in parallel and improve the performance of each server to be faster. That is because in RAC, regardless of the number of existing servers will be only one Server. RAC is working in high availability, which means

the demand data will be directly addressed by all servers in the node RAC to work together (Mahalingam, 2009).

## 2.4 SYSTEM DESIGN

Work methods or steps performed in installing Real Application Cluster (RAC) by using the Storage Foundation are:

The first stage should be done is to analyze the problem in regard to the use of the Storage Foundation Enterprise Linux Real Application Clusters by doing a short test to find out the weakness of the system. SAN is the biggest part in designing the architecture RAC DRBD. In this section, we prepare all the hardware that supports the need for system requirements. This includes determining the number of nodes that will be implemented, determine the operating system, processor and memory and LAN network design, network design interconnected, network design for the database to the IP addressing (public ip, virtual ip and private ip). After the design process is done, the logical design is shown. Mentioned earlier in the logical system synchronization occurs when the server is active/active (Main Server and Cluster Server). RAC is running the synchronization.

RAC has two servers, or nodes, namely node 1 and node 2 and consists of a Storage Foundation RAC, it can be seen on Figure 2. Each server or node has four NIC card. NIC card is used to connect to each server/node, connecting node 1 to node 2 (peer-peer connection) and connect the second Server with Storage Foundation Real Application Cluster. Server/node has more than one NIC because if there are interference or a fault in one of the NIC to another NIC to work. Host Bus Adapter (HBA) was used to connect a server/node with Fibre Channel (FC) which is connected to the Storag/hard drive. By using the node and more than one NIC then RAC has high availability.

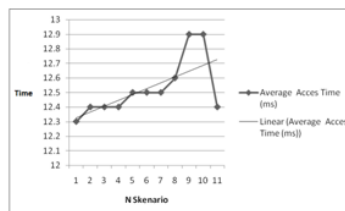

Figure 4: Average access time of service

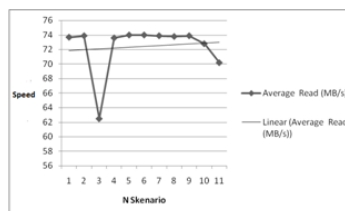

Figure 5: Average Speed of Reading Disk

At the Application Client sends a request, the request will be submitted to the server/node through Local Area Network (LAN) connected to the switch and the switch has been connected to the server/node. After a request to each server/node then the server/node will identify and send the request to the storage/harddisk, then the next client request Application will be answered and sent to the client.

Figure 3 shows the redundancy of SAN. The data contained in the node 1 will also be on node 2, if there are problems at node 1 then node 2 will meet customer demand and the customer does not need to be queue or cannot access the request. With the data on node 1 and node 2 then Server/node will never stop. Server/Client Application nodes connected by using a public IP, while between node 1 and node 2 is connected with a private IP. Each node also uses a virtual IP because the virtual IP address used alternative public client in addition to the standard IP address. Otherwise virtual IP can be said IP multipathing, which can recognize the public IP and private IP.

### 3 SIMULATION RESULTS

Those testing carried out in several scenarios. For the first scenario is testing Storage (disk), measuring the performance of Redundant Array of Independent Disks (RAID). On the measurement of the variation in the RAID configuration of each server such as RAID 6 for each node Server (Main Server and Cluster Server) and RAID 0 for Storage Foundation Enterprise Linux Real Application Clusters. Both measurements were taken from the Performance Memory, I/O and CPU. Final analysis is to observe the real Enterprise linux Application Cluster (RAC).

DRBD RAID mechanism is analogous to the duplicating data across the network. Duplication of data is done in the mechanism of block devices, not in the form of raw data. When RAID duplicates the content and data of a hard disk or partition to another hard drive or partition, DRBD does the same thing, only done through the network. DRBD and RAID hard drives are mutually supportive. DRBD has one advantage over RAID hard drive, which is a separate backup server with a backup source. This separation brings preventive benefits, if there is a problem on one server, another server will act as a server replacement. If the primary server has recovered, the control will be returned to the main server.

Where:  $MTTR = 0$ ,  $MTTR$  ignored because every time down time directly in the take-over by Cluster Server so that the services remain the way as it should without any delay. Thus:

$$MTBF = MTFP$$

$$Availability = MTFP/MTBF = 100\%.$$

### 4 CONCLUSION

Real Application Clusters (RAC) is a method for designing large-scale database that can handle 24-hour service. RAC allows many servers in parallel to unify and improve the performance of each server to be faster. Availability and performance comparable to the ratio of the instantaneous failure occurs with the average time taken in the recovery process. Performance comparison of the results obtained from the packets transmitted by the number of packets sent. SAN Performance = 93.396%, Main and Cluster Server Performance =

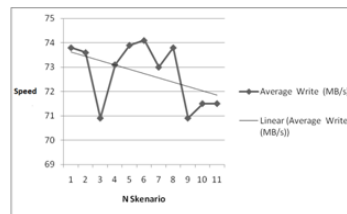

Figure 6: Average Speed of Writing Disk

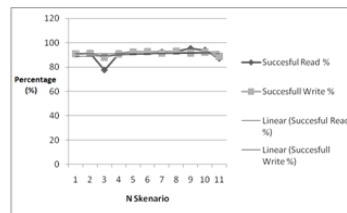

Figure 7: Successful Rate of Read / Write Service

29.4945%.SAN intended to serve clients with the support of both node server (Main and Cluster Server).

Write slower than Read when accessing the server and storage. When performing activities Read the process is not through the CPU and memory cache but directly to the Storage. Write activity while the process is going through the CPU, memory cache to the storage, so that Write is slower than the Read. Nowadays, RAC based on SAN can be operated on high end technology only and the maintenance cost also high. For further research, RAC based SAN can be operated for every data center with low cost.

## 5 ACKNOWLEDGMENT

This research was financially supported by National Research Foundation of Korea (NRF) through the Human Resource Training Project for Regional Inocation 2014 (NO. NRF-2012H1B8A2026) and the MSIP (Ministry of Science, ICT and Future Planning), Korea, under the Creative ICT Convergence Human Resource Development Program.

## References

- Anil Vasudeva. SAS, SAN, NAS-Past, Present, and Future. (2000). *IMEX Research*, San Jose, California. USA
- Calves, J. (2004). *Veritas Storage Foundation for DRBD 9i RAC and DB2 UDB V8 on IBM pSeries*. France: IBM.
- Dyke, Julian & Steve S. (2006). *Apress Pro ORACLE Database 10g RAC on Linux*. New York : Apress Publishing Company.
- Emmanouil Serrelis, Nikos Alexandris. (2007).From High Availability Systems to Fault Tol-

- erant Production Infrastructures. *Third International Conference on Networking and Services*. June 2007. 99
- Greenwald R, S Stackowiak & Stern J. (2007). *ORACLE Essentials: ORACLE Database 11g*. United States: O'Reilly Publishing, Inc.
- Guo Hui, Zhou Jingli, LI Yue, YU Shengsheng. (2004). Design of A Dual-Computer Cluster System And Availability Evaluation, *Proc. IEEE International conference on Networking, Sensing & Control*, March 21-23, 2004, 355-360.
- Hoot Thompson, Bill Fink, Curt Tilmes, Paul Lang, Robert Cavey, Ben Kobler. (2003). Considerations and Performance Evaluations of Shared Storage Area Networks At NASA Goddard Space Flight Center. *Proceedings of the 20th IEEE/11th NASA Goddard Conference on Mass Storage Systems and Technologies*, April 2003. 135-144.
- Jianxi Chen, Dan Feng. (2006). VISA: a virtual interface Storage architecture for improved network Performance. *Second International Conference on Embedded Software and Systems*, April 2006. 6 pp.
- Jhon H. Hartman, Ian Murdock, and Tammo Spalink. (1999). The Swarm Scalable Storage System, *Proc. IEEE International Conference on Distributed Computing Systems 19th*, August 2002. 74-81.
- Jun Liu, Baojiang Cui. (2009). Performance Prediction of Distributed RAID Storage System. 2009. *The 1st International Conference on Information Science and Engineering*. Dec 2009. 311-314.
- Jun Liu, Baojiang Cui. (2009). Performance Prediction of Distributed RAID Storage System. *The 1st International Conference on Information Science and Engineering*. Dec 2009. 311-314.
- Nava Aizikowitz, Alex Glikson, Ariel Landau, Bilha Mandelson, Tommy Sandbank. (2005). Component-Based Performance Modeling of a Storage Area Network. *Proceedings of the 2005 Winter Simulation Conference*, Dec 2005. 10 pp.
- P. Mahalingam, N. Jayaprakash, S. Karthikeyan. (2009). Enhanced Data Security Framework for Storage Area Networks. *Second International Conference on Environmental and Computer Science*, Dec 2009. 105-110.
- R. Buyya (editor), *High Performance Cluster Computing: Architectures and Systems*, Vol. 1, Prentice Hall PTR, NJ, USA, 1999.
- Taylor, Dave. (2003). *Solaris 9 for Dummies*. Indiana: Wiley Publishing, Inc.
- Xiangqun Qui, Radha Telikeyalli, Tadeusz Drwiega, James Yan. (2005). Reliability and Availability Assessment of Storage Area Network Extension Solutions. *IEEE Communications Magazine*, March 2005. 80-85.

# IPV6 Readiness Survey: The Case of Indonesian Organizations

Dedy Syamsuar, Peter Dell

Curtin University

e-mail:Dedy.sya msuar@postgrad.curtin. edu.au P.T.Dell@curtin.edu.au

Universitas Bina Darma

dsyamsuar@mail.binadarma.ac.id

## *Abstract*

*Recently, the Internet has become a crucial part of human life where various sectors depend on the technology. With the significant development of the Internet, the IPv4 as common IP address standard is predicted not able to accommodate the Internet and internet-based technologies growth. Then, the IPv6 was introduced in 1998 as a de facto standard to overcome the problems of IPv4. Although IPv6 technology has been available for decades, however, it has not yet become widely implemented. This empirical study investigates Indonesian organizations readiness for IPv6. Currently, Indonesia is the fourth largest country in the world, and the allocation of IP address to the country is extremely small, compared to the total population and other major countries. Surveying wide range organizations in Indonesia, the result indicates that although there is high awareness among the organizations and they believe IPv6 is important, IPv6 is perceived less urgent to be implemented. Consequently, the organizations dont put a lot of preparation for five readiness criteria, namely training, planning, assessment the current environment, policy and IPv6 deployment.*

**Keywords :** IPv6 , Indonesia, readiness

## 1 INTRODUCTION

The number of Internet users reach 3.035 million by the end of 2014 and penetrate up to 42.3 of the world total population (www.InternetWorldStats.com, 2014). The growth of the Internet tends to continue significantly (OECD, 2014). This is because of many new technologies (e.g. mobile , flexible and always on communication system) requiring the Internet connection to enable their system (Hovav et al., 2004; Tassej et al., 2009), and a fast growth of the Internet in developing countries (Che & Lewis, 2010).

With the significant growth of the Internet, numerous authors (Bohlin, 2002; Colitti et al.,2010; Hain & Huston, 2005; Karpilovsky et al., 2009) have shown their concern to the current Internet Protocol address limitation. Basically, every device connected to the Internet must have an IP address as connection permits (Dell, 2011). Karpilovsky et al. (2009)



argue that the IPv4 will not be able to provide adequate services for the future Internet. Similarly, other authors (Bohlin, 2002; Colitti et al., 2010) informed that the high demand of the Internet connection has driven to the migration to a much larger address space and the migration becomes a high priority to overcome serious Internet problem in the future (Mueller, 2006).

On 3rd February 2011, ICANN as the IP regulatory body announced that they have allocated the last IPv4 blocks to the five RIRs (Regional Internet Registry). Obviously, it indicates that address shortage has become a real problem where almost entire available IPv4 addresses have been allocated (Dell, 2011). And recently, it is reported that the worldwide number of allocation of IP addresses reached approximately 3.6 billion by the end of 2014 (www.MaxMind.com, 2014). The current protocol can theoretically accommodate up to about 4.3 billion addresses. In the actual implementation, however, the numbers decrease significantly due to several following reasons (Cotton & Vegoda, 2010). Firstly, some addresses are not available to public since they reserve only for private addresses and loopback. Secondly, ICANN allocates several addresses for particular purposes, namely multicast (class D) and future use. The combination of the two previous reasons contributes to nearly 600 million addresses unavailable to the public. Finally, many addresses allocated to the user are not actually used due to the inefficiency of classes concept on IPv4. However, there is no data reported the precise number of this category.

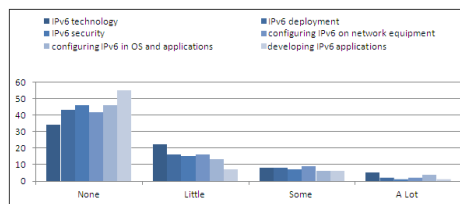

Figure 1: Level of IPv6 training (n = 69)

IPv6 or next generation IP has been almost two decades available as a solution (Shen et al., 2009) and standardized on 1998 (Deering & Hinden, 1998). It is not necessary only to extend the address space number but to solve other problems introduced by the current IP (Durdagi & Buldu, 2010; Mueller, 2010), such as security and mobility. However, the adoption remains minimal (Che & Lewis, 2010; Limoncelli, 2011). Elmore et al. (2008) predicts that it will be about 8 to 22 years to full adoption based on the current trends or even more (Dell, 2010). Mueller (2008) argues that the impact of the address scarcity would be similar with the impact of oil crisis in the era of 1970s. Obviously, where the Internet has become a critical resource and widely used (Wellman & Haythornthwaite, 2008), it will significantly affect many aspects of modern human life, when the development has to stop.

## 2 RESEARCH METHODOLOGY

This research examines the technology readiness of Indonesian organizations for IPv6. Since the decision to adopt and implement IPv6 is made at an organizational level, this research targeted a wide range of organizations as the end users of Internet Protocol. There is still very little known about IPv6 development in Indonesia, especially to end-user organiza-

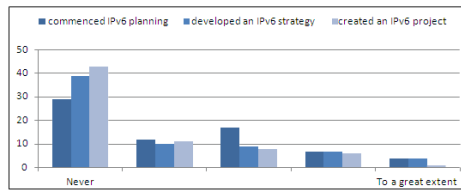

Figure 2: Level of IPv6 Training

Table 1: Respondent Industries (self-reported)

Industry	Response	Industry	Response
Agriculture	4	Mining	7
Communication/Telecommunication	5	Property	2
Education and Training	27	Retail Trade	5
Finance and Insurance	7	Software Developer	4
Government Administration and	2	Transport and Storage	1
Health and Community Services	2	Vendors (software / hardware)	1
IT Consultant	8	Wholesale Trade	1
Manufacturing	4	Other Organization	8

tions. We define end-user organization as an organization which uses computer networks or Internet in their operations. The research sample was IT policy makers or those who were responsible to manage their computer networks, included middle or senior managers and also other IT-related positions associated with the organizations computer network. We adapt the instrument from previous readiness study for IPv6 by Dell (2011). There are five aspects measured in this study related to organizations readiness along with respondents opinion about the importance and urgency of IPv6.

An online survey was used to obtain data from respondents. The invitation email was sent to a total of 390 respondents. There were two groups of respondents. The first group consisted of a wide range of organizations were randomly obtained from social media (LinkedIn), supplemented by snowball sampling of further organizations recommended by participants. It was ensured that respondents organizations utilized computer network technology in their operations. 264 invitations were sent and 47 valid responses were received, giving a response rate for this group of 17.8%. The second group consisted of top 100 universities listed on Webometric. We also surveyed the local node of the Indonesia High Education Network (Inherent) where they were not listed on Webometric. We selected both of these groups since it is likely that they significantly rely on computer network technology on their operations. There were total of 122 invitations sent in this category, resulting in 27 valid responses, giving a response rate of 22%.

In term or respondents position, Policy makers (such as CIO and IT manager) and Network Administrator dominated up to 71% of the total respondents. The 29% of respondents were in other IT professional positions that also have a strong connection to the network environment, such as those who responsible for network security and design. Table 1 indicates the distribution of respondents industry.

Table 2: Reason for belief in the Importance of IPv6

Important	Not important
Lack of capacity of IPv4	The issue was not perceived as relevant to the respondents organization
To anticipate technological development	Minimal need for public address space
To provide better security	Satisfaction with IPv4
Reputational benefit from IPv6 deployment	

Table 3: Reason for belief in the Importance of IPv6

Urgent	Not urgent
IPv4 has been fully allocated	IPv4 is still able to accommodate the
NAT prevents end-to-end communication	Internet connection
A significant increase in IP-connected technology	NAT solves the problem
Need to increase network security	The issue was not perceived as relevant to the respondents organisation
	The respondents organisation has sufficient IPv4 address space

### 3 RESULTS AND DISCUSSION

#### 3.1 Awareness, Importance and Urgency

The level of IPv6 awareness was extremely high: only 7% of respondents who had heard of IPv6 continued with the survey. These respondents were asked how important they believed IPv6 to be: 73% believed that IPv6 is important and only 10% believed it is not. Further, respondents were asked to provide reasons for their choice. The most frequently cited reasons for a belief in the importance or lack of importance are summarized below:

In term of urgency to move, only 42% of respondents believe it is an urgent issue and 38% are not. In this question, the numbers of respondents who believe IPv6 is urgent are slightly different from those who believed it is not. Table 3 summarizes the common reasons for these beliefs.

#### 3.2 Level of training

There were six questions about the extent to which organizations had conducted IPv6 training. The results are presented in Figure 1.

Very few Indonesian organizations have conducted much IPv6 training. Among the training categories, only general training about IPv6 has been conducted by roughly half the respondents. This low level of training in Indonesian organizations will affect the availability of IPv6 skills among IT people it will likely not be possible simply to hire people from outside the organization when necessary.

IP is not only about addressing, but it is a foundation technology to allow communication through the Internet or computer network. IPv6 is not backward compatible and is quite different to the previous version; hence organizations should increase IPv6 knowledge among to facilitate a successful IPv6 implementation.

### 3.3 Planning

Respondent organizations were questioned about the extent to which they had commenced IPv6 planning, developed an IPv6 strategy and created IPv6 projects. The responses are summarized in Figure 2.

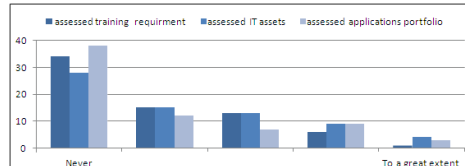

Figure 3: Assessment of the IT environment

Consistent with the perceived importance of IPv6 among most of organizations, approximately half of the respondents indicated that they have already commenced planning for IPv6 at least to a small extent. However, far fewer organizations had developed an IPv6 strategy or created an IPv6 project, indicating that planning in Indonesian organizations has generally been conducted only at a basic level.

In terms of planning, one respondent highlighted the important of planning thus: it will be difficult if we take action in short time. Indeed, according to Grossetete et al. (2008), early planning and having an IPv6 strategy could significantly reduce the switching cost and operational risk. An organization needs a clear direction to implement a new technology when many aspects will involve people, devices, applications and services. Planning is also important to prevent unnecessary work and minimize failure of its implementation.

### 3.4 Assessment of the IT Environment

Respondents were questioned about the extent to which they had assessed their training needs to implement IPv6, their IT assets and their application portfolio. The responses are summarized in Figure 3.

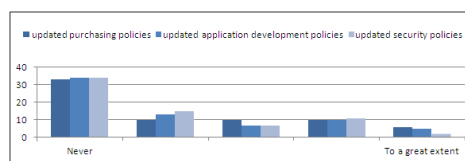

Figure 4: Policy Readiness

It is important to ensure that an organization has sufficient resources for broad deployment of IPV6. The results indicate that very few organizations have made significant steps to determine the potential impact of IPv6.

Vint Cert, one of the Internets founder, argues that IPv4 will not be able to provide the necessary IP addresses, and hence migration to IPv6 is a matter of time. Organizations need to assess what resources have to be provided to start IPv6 implementation. This step will lead the organization to introduce a specific policy in order to make a smooth transition.

The results also indicate that, very few respondents have reviewed their application portfolio. In some cases applications do not care which IP version is used in the underlying network. However, ensuring that applications support IPv6 is also important to decrease the cost of upgrade as network-aware applications will likely be affected by the transition to IPv6.

### 3.5 Policy

The organizations were also questioned about the extent to which they had updated their policy framework to prepare for IPv6. The responses are summarized in Figure 4.

Very few organizations have updated relevant policies to prepare for IPv6. Only a small proportion of organizations have updated purchasing policies, although the cost to do so is minimal: almost 50% of organizations have not updated their purchasing policy to ensure the purchasing of IPv6-capable equipment. However, it could potentially cost a lot when they have to implement IPv6 if they have to replace IPv6-incapable equipment.

One of barriers to adoption of a new technology is switching cost, especially with incompatible technologies. However, early anticipation can reduce the costs that may arise, for example set conditions in the procurement of IPv6 ready networking devices.

### 3.6 Deployment status

Finally, respondents were asked about IPv6 deployment generally and about IPv6 address planning, which is often associated with deployment. The responses are summarized in Figure 5.

Very few Indonesian organizations have deployed IPv6. This is not surprising, given the low level of preparation for IPv6 in other areas. Interestingly, a small proportion of respondents have fully deployed IPv6 on their network, mostly from Education and Telecommunication sectors.

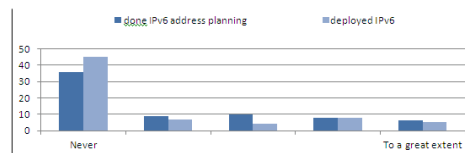

Figure 5: IPv6 Deployment

## 4 CONCLUSION

The results from this survey indicate that the level of awareness of IPv6 among Indonesian end-user organizations is extremely high and the majorities believe that IPv6 is important, due to problems imposed by continued use of IPv4 and to cater to increased demand for Internet-connected devices. However, few consider IPv6 as an urgent issue, with many believing that the current technology can still accommodate their needs.

Although IPv4 address space has been fully allocated globally, it seems that many Indonesian organizations have not taken significant steps towards IPv6y. Deploying IPv6 takes multidimensional effort and needs a comprehensive approach involving people, devices, appli-

cations and services, for which many Indonesian organizations seem ill-prepared. The implications of this lack of readiness could include increases costs, risks and unforeseen difficulties that result from hurried and poorly planned deployment in the future.

Finally, although Indonesia is poorly-served by IPv4 in comparison to many other countries, particularly those in the developed world, the lack of preparation taken by Indonesian organizations suggests they will continue to rely on IPv4 in the foreseeable future. Nevertheless, Indonesia has an opportunity to take a leading role in IPv6 and become a world leader in its deployment; given the increasing reliance on the Internet in a vast range of industries and sectors combined with the state of IPv4 in Indonesia compared to other countries, we must ask whether this is an opportunity that can afford to be missed.

## References

- Bohlin, E. (2002). Incentives to Innovate with Next Generation Networks. *Communications & Strategies*, 48(4).
- Che, X., & Lewis, D. (2010). IPv6: Current Deployment and Migration Status. *International journal of research and reviews in computer science*, 1(2).
- Colitti, L., Gunderson, S., Kline, E., & Refice, T. (2010). Evaluating IPv6 Adoption in the Internet. In A. Krishnamurthy & B. Plattner (Eds.), *Passive and Active Measurement*. Vol. 6032, pp.141-150). Heidelberg: Springer Berlin.
- Cotton, M., & Vegoda, L. (2010). Special-Use IPv4 Addresses (RFC 3330). *Internet Engineering Task Force (IETF)*. Retrieved from <http://tools.ietf.org/html/rfc3330>
- Deering, S., & Hinden, R. (1998). Internet Protocol, Version 6 (IPv6) Specification (RFC 2460). *The Internet Society*. Retrieved from <http://www.ietf.org/rfc/rfc2460.txt>
- Dell, P. (2010). Two Economic Perspectives on the IPv6 Transition. *Info*, 12(4).
- Dell, P. (2011). Australian IPv6 Readiness: Results of a national survey. *Journal of Research and Practice in Information Technology*, 43(4).
- Durdagi, E., & Buldu, A. (2010). IPv4/IPv6 Security and Threat Comparisons. *Procedia - Social and Behavioral Sciences*, 2(2).
- Elmore, H., Stephens, B., & Camp, L. J. (2008). *Diffusion and Adoption of IPv6 in the Arin Region*. SSRN eLibrary.
- Grossetete, P., Popoviciu, C., & Wettling, F. (2008). *Global ipv6 strategies: from business analysis to operational planning*: Cisco Press.
- Hain, T., & Huston, G. (2005). A pragmatic report on IPv4 address space consumption. *The Internet Protocol Journal*, 8(3).
- Hovav, A., Patnayakuni, R., & Schuff, D. (2004). A model of Internet standards adoption: the case of IPv6. *Information Systems Journal*, 14(3).

- Karpilovsky, E., Gerber, A., Pei, D., Rexford, J., & Shaikh, A. (2009). Quantifying the Extent of IPv6 Deployment In S. Moon, R. Teixeira & S. Uhlig (Eds.), *Passive and Active Measurement*. (Vol. 5448, pp. 13-22). Heidelberg: Springer Berlin.
- Limoncelli, T. A. (2011). Successful Strategies for IPv6 Rollouts. Really. *Communications of the ACM*, 54(4).
- Mueller, M. (2008). *Scarcity in IP addresses: IPv4 Address Transfer Markets and the Regional Internet Address Registries*. Retrieved on 20/12 2011 from [http://www.internetgovernance.org/pdf/IPAddress\\_TransferMarkets.pdf](http://www.internetgovernance.org/pdf/IPAddress_TransferMarkets.pdf)
- Mueller, M. (2010). Critical resource: An institutional Economics of the Internet Addressing-routing Space. *Telecommunications Policy*, 34(8).
- OECD. (2014). *The Internet in Transition: The State of the Transition to IPv6 in Today's Internet and Measures to Support the Continued Use of IPv4*: OECD Publishing.
- Shen., W., Chen., Y., Zhang., Q., Chen., Y., Deng., B., Li., X., et al. (2009). Observations of IPv6 traffic. *Paper presented at the Computing, Communication, Control, and Management, 2009*.
- Tassej, G., Gallaher, M. P., & Rowe, B. (2009). Complex Standards and Innovation in the Digital Economy: the Internet Protocol. *International Journal of Technology Management*, 48(4).
- Wellman, B., & Haythornthwaite, C. (2008). *The Internet in Everyday Life*. Hoboken: Wiley-Blackwell.
- www.InternetWorldStats.com. (2014). *Internet Usage Statistics*. Retrieved on 01/09/2014 from <http://www.internetworldstats.com/stats.htm>
- www.MaxMind.com. (2014). *Allocation of IP addresses by Country*. Retrieved on 01/09 2014 from <http://www.maxmind.com/app/techinfo>

## Similarity Analysis of Audio Steganography Combined With Rijndael Cryptography Algorithm

Hudson Leroy Simanjuntak, Anggoro Suryo Pramudyo,  
Rian Fahrizal

Universitas Sultan Ageng Tirtayasa  
e-mail: hudsonleroy@gmail.com, pramudyo@untirta.ac.id, rianf@yahoo.com

### *Abstract*

*The rapid development of digital media and its use are covered various fields give rise to greater demands for creating an information delivery system that is secured. There are two techniques used to secure the message, cryptography and steganography. Cryptography is used to scramble the message (encryption), so that others, who have an interest in it, cannot read messages without a password. While steganography is used to hide messages in different media (carrier file). The method used is the Rijndael algorithm in cryptography and Least Significant Bit (LSB) on steganography. File carrier is audio mp3 and message is text files (txt). Audio mp3 has some kind of musical genres, so that course of a study conducted to determine the effect on the quality of the music genre of audio steganography produced. Some samples genre of music used is country, jazz, pop, reggae and rock. Application of audio steganography technique consists of testing the success of the process of embedding, extracting, playing and testing of similarity. After comparison of all test results, then we obtain the best genre in security system audio steganography technique is a genre of rock with a similarity value of 81.39%.*

**Keywords :** mp3 genre, steganography

## 1 INTRODUCTION

Steganography is a technique of hiding information in digital media in such a way that no one apart from the intended recipient knows the existence of the information (Ashok et al. 2010). Information security becomes an inseparable part in digital world today. As the technology advances, the risk of threats to information will be even greater, especially in the information confidential. Various threats from cyberspace as hackers and crackers can increase the risk of leaking the information to the parties that are not desired. Concerns that causes delays in the delivery of information, while the information is needed by certain parties. In an effort to improve safety and comfort in the process of sending digital files both locally and connected to the internet, it takes a method and appropriate mechanisms to secure communication in a digital file, that is by disguising digital content in other media,



but the file is not damaged and still can be used by the user. This technique is known as steganography, the data hiding technique using a carrier medium (carrier).

Mp3 audio is a promising carrier format for covert communication because of its popularization (Yan et al. 2012). Since the last 6-7 years, the audio file format that is becoming popular until now. Although other types of compression that some have better quality, but cannot be rivaled mp3 today. The widespread use enables mp3 audio files to become excellent covers to carry hidden information in audio steganography on the Internet (Qiao, Sung, & Liu, 2013). Traffic exchanges mp3 on the internet is common so steganography using mp3 is a good technique for securing confidential messages via the Internet.

## 2 EXPERIMENTS

### 2.1 Software

Mp3stegz v.1.1.0.0 is software that is used for embedding and extracting the text file into mp3 file. This software uses LSB method for steganography. The text file will be encrypted and decrypted using Rijndael algorithm. Another software is Similarity Version 1.9.1 (x86) Build 1844. Its used for analyze the similarity of mp3 files. The similarity is analyze from the content, tags, and precise of the mp3 file. Similarity of content is analyzed by compare the contents of sound similar uses voice analysis techniques. Similarity of tag is analyzed from comparative information residing on mp3 audio files, such as information artist, title, album, bit rate, sample rate, size, duration, channels and so on. Similarity of precise is analyzed the mp3 audio file content comparisons from byte to byte overall.

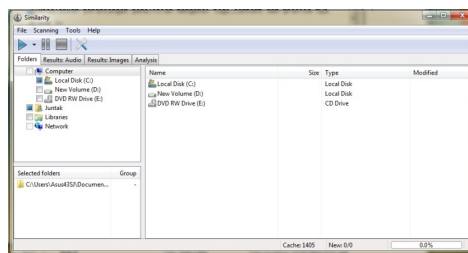

Figure 1: Similarity Version 1.9.1 (x86) Build 1844

### 2.2 Experiment Design

The process of research conducted to obtain data and get the results as expected refers to the purpose of research is to determine whether a particular genre of music can affect the quality of the resulting audio steganography using the Least Significant Bit (LSB). In the study used five (5) has been a popular genre of music to be heard, it aims to simplify the process of analyzing the quality assessment of audio mp3. Sample-determination process for the genre of music is done freely and randomly to provide 20 samples in every genre of music to the parameters that are used not only refer to the sample at any given genre.

## 2.3 MP3 Files Testing

The test file was exacting and thorough in mp3 audio file that has undergone insertion of text, some of the parameters that must be considered in conducting the testing is successful embedding, extracting and can be played (playing) the mp3 file. The return message information intact become a benchmark in determining the success of the process steganography applied, because the essence of the use of steganography is to secure the confidentiality of a message in the process of digital data communication. Tests were also performed using the software similarity to know how resemblance an mp3 audio files to other audio mp3. While the study was used to measure the degree of similarity of the original audio file to mp3 audio files that have been inserted message information (file embedding) using analytical calculation of content, tags and precise.

## 3 RESULTS

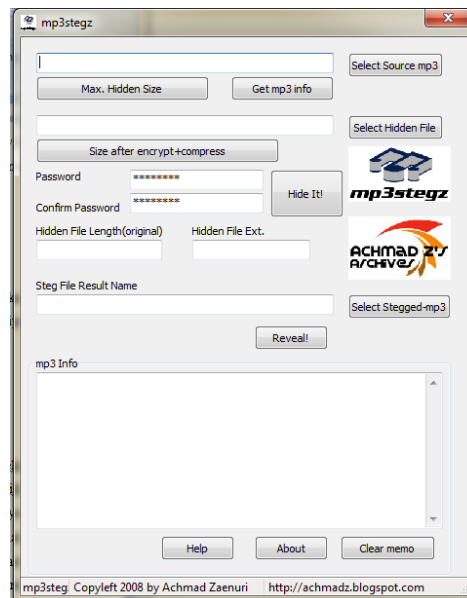

Figure 2: Mp3stegz v.1.0.0

### 3.1 Embedding Process Testing

After the insertion process the message information into the file sample carrier against all genres of music is used, the obtained result of the embedding process as a whole is as follows:

$$\begin{aligned} \text{Percentage of Successful Testing} &= \frac{n \text{ test} - n \text{ failed test}}{n \text{ test}} \times 100\% \\ &= \frac{100 - 0}{100} \times 100\% = 100\% \end{aligned}$$

### 3.2 Extracting Process Testing

After the process of extracting the information revealing the message that has been inserted (text file) on each sample genre of music used, the obtained results of the overall success of the extracting process is as follows:

$$\begin{aligned} \text{Percentage of Successful Testing} &= \frac{n \text{ test} - n \text{ failed test}}{n \text{ test}} \times 100\% \\ &= \frac{100 - 0}{100} \times 100\% = 100\% \end{aligned}$$

### 3.3 Testing Process Playing

Basically damage to the mp3 audio file must have happened after undergoing a process of insertion of information, but the damages sought are not significant, so the file is still similar to the original mp3 file so as not to arouse suspicion from the other party to the information embedded in the mp3 audio. Test results playing process is as follows:

$$\begin{aligned} \text{Percentage of Successful Testing} &= \frac{n \text{ test} - n \text{ failed test}}{n \text{ test}} \times 100\% \\ &= \frac{100 - 0}{100} \times 100\% = 100\% \end{aligned}$$

### 3.4 Similarity Test Results

Similarity test is done between the original audio and audio files that have been inserted message information. Similarity is analyzed from their content, tags and precise. The results obtained from testing the similarity of the analytical calculation of the content in all genres of music samples, namely the genre of country, jazz, pop, reggae and rock has similarities to the original file with an average value of 100%. The results obtained from testing the similarity of the analysis on the sample tag calculations genre of country, jazz, pop and reggae was 41.7%. While in the rock genre has the highest average value, ie 44.18%. The results obtained from testing the similarity of the precise calculation analysis on all samples genres of music, which is a genre of country, jazz, pop, reggae, and rock has similarities to the original file with the average value of 100%.

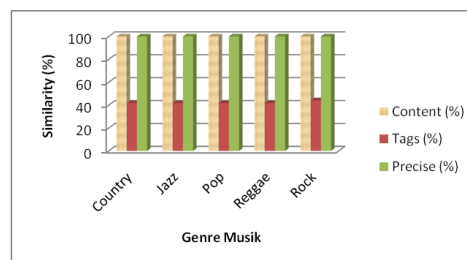

Figure 3: Similarity of content, tags, and precise of each music genre

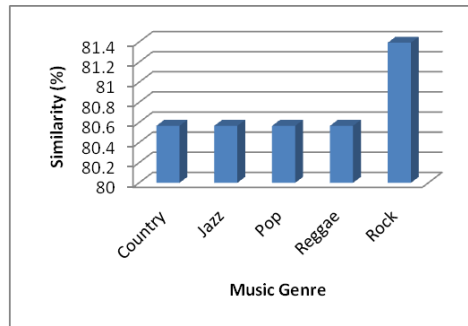

Figure 4: The average of similarity for each music genre

#### 4 CONCLUSION

The results of this experiment are:

1. The similarity of content and precise of all genres is 100
2. The similarity of tags of country, jazz, pop, and reggae is 41.7%, while rock is 44.18%.
3. Rock genre has 81.39% of similarity, and the others (country, jazz, pop and reggae) have 80.56%.

#### References

- Ashok, J. et al., (2010). STEGANOGRAPHY: AN OVERVIEW. *International Journal of Engineering Science and Technology*, 2(10), pp.59855992. Available at: <http://www.ijest.info/docs/IJEST10-02-10-100.pdf>.
- Qiao, M., Sung, A.H. & Liu, Q., (2013). MP3 audio steganalysis. *Information Sciences*, 231, pp.123134.
- Yan, D. et al., (2012). Steganography for MP3 audio by exploiting the rule of window switching. *Computers and Security*, 31(5), pp.704716.

# The Real Monitoring of Three Phases Power Based on Microcontroller Which Can Be Readed Online (Case Study in Laboratory of Microprocessor of Padang State Polytechnic )

Anggara Nasution, Rusfandi, Era Madona

Electrical Department, Padang State Polytechnic  
Building B, 1st Floor, Campus of Padang State Polytechnic Padang  
Padang - 72590  
e-mail: bangangga81@gmail.com, emadona38@gmail.com

## *Abstract*

*The development of more modern technology, requires us to constantly develop the technology of electrical measurement from the conventional system into a digital system that works in real time. Using the tools of three phases power monitoring system to be able to see how much power is used, which is known from the current load on the phase R, S and T are detected and processed by the arduino would facilitate implementing monitoring with display the power on the LCD. In addition to the application of the Ethernet Shield, the data can be stored in a MySQL database and can be displayed on the web, so that implementers can monitor periodically checks easily, anywhere, anytime while connected to the ethernet.*

**Keywords :** *arduino Ethernet Shield, ethernet, load, monitoring, mysql*

## 1 INTRODUCTION

Along with the development of technology, it takes practicality in all respects, including the implementation of the monitoring system in real time. One application of monitoring technology is the amount of electricity monitoring system in real time. One of the benefits obtained by the measurement of electrical quantities in realtime is monitoring the use of electrical energy. This monitoring aims to get the latest data and the data can be processed to get the chance of electrical energy efficiency.

Real time monitoring of electrical quantities of data will be measured using CT sensors, the sensor readings forwarded to the microcontroller for processing and then stored in database. To display the existing data in the database is displayed through a web browser. Making it easier for admins to see the results of the current sensor circuit in the form of graphs. For the manufacture of GUI is used PHP software, Ajax and Java script. By using real time technology is expected to provide the following benefits :

1. Can display the electrical quantities of data in real time.

2. Process the data of the electrical quantities to obtain accurate data relating to the quality and quantity of the electrical quantities.

Research About the real time monitoring of these previously been done by Yusnan Badruz-zaman in 2012. Commercial products which contain real time data monitoring program has also been made by one brand that operates in the field of industrial automation, namely Schneider Electric. They launched called ION Enterprise software. Power Logic ION Enterprise is a software that provides a complete power management solution for energy providers and industrial or commercial operations. This software provides engineering and management information they need to cut costs related to energy, avoid downtime and optimize the use of equipment.

### 1.1 The Three Phases Systems

In the 3-phases power system, ideally electric power generated, distributed and absorbed by the load everything balanced, P generation = P usage, and also on a balanced voltage. In a balanced voltage 1 phase consists of a voltage having the same magnitude and frequency but between one phase to another have a phase difference of  $120^\circ$  electricity, while physically have a difference of  $60^\circ$ , and can be connected in star (Y, wye) or triangle (delta,  $\Delta$ , D) (Srividyadevi P., Pusphalatha D.V. and Sharma P.M, 2013) . The number of power supplied by a generator 3 phases or the power absorbed by the load 3-phase, obtained by summing the power of each phase. In a balanced system, the total power equal to three-phases power, because power in each phase is the same (Katsaparakakis, et.al, 2008) If the angle between current and voltage is equal to  $\theta$ , then the amount of power each phases are :

$$P_{phase} = V_{phase} \cdot I_{phase} \cdot \cos \theta \quad (1)$$

while the total amount of power is the root multiplication three of the amount of power per phase, and can be written by

$$P_T = \sqrt{3} \cdot V_f \cdot I_f \cdot \cos \theta \quad (2)$$

### 1.2 Electrical Power

#### 1.2.1 Active power

Active power is commonly used by consumers. Active power is what usually can be converted into work. Unit active power expressed in watts. Active power (real power) (Suryatmo, 1997) obtained from the equation:

$$P = V \cdot I \cos \theta (kW) \quad (3)$$

#### 1.2.2 Reactive power

Reactive power is the amount of power required for the formation of a magnetic field. From the formation of the magnetic field (Suryatmo, 1997) . It will form a magnetic flux. Reactive power unit expressed in Var obtained from the equation :

$$Q = V \cdot I \cdot \sin \theta (kV Ar) \quad (4)$$

Table 1: .Comparison of ADC with Current Measured Value In Each Phase Value

ADC Value	Current Measured (A)	ADC Value	Current Measured (A)
512	0	744	2.81
533	0.15	786	3.25
561	0.61	829	3.75
592	1.02	873	4.19
626	1.5	918	4.68
663	1.82	964	5.03

## 2 RESEARCH METHODOLOGY

In this section, presented a brief discussion of the design and implementation of the system and explained about how the system works contained in the outline of the design of the system and is followed by a description of the hardware (hardware) which consists of several parts that serve to cultivate the data. Kemudian followed by design and the creation of software.

### 2.1 Design of Hardware

#### 2.1.1 Electronics circuit 3 Phases Power Monitoring Tool

Figure 1 above shows the electronics circuit of 3 phases power monitoring tool. The circuit is divided into five parts, namely (1) the current sensor circuit R. (2) current sensor circuit S, (3) current sensor circuit T, (4) Circuit Microcontroller ATmega3128, (5) LCD circuit.

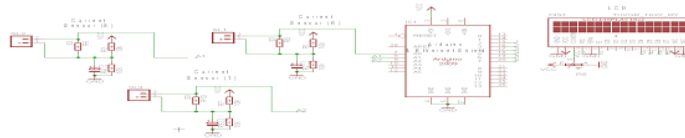

Figure 1: electronics circuit 3 Phases Power Monitoring Tool

#### 2.1.2 Current Sensor circuit with CT Sensor

Current sensor is designed using CT sensor. These sensors change the magnitude of the primary current into the secondary current magnitude with a certain ratio and phase angle difference has nearly zero on the polarity of the corresponding relations (Open Energy, 2014). Magnetic Field happens to the conductor plate will be captured and converted to a DC voltage. This output will be forwarded to the microcontroller ADC PORT namely A0, A1 and A2 are previously passed several supporting components. Then the output will be converted into units of amperes in accordance with the current read on the measuring tool pliers amperes. Here is a table 1 that shows the results of the conversion.

## 2.2 Implementation of the Arduino Ethernet Shield with Electronic circuit 3 Phases Power Monitoring Tool For WebClient

The arduino used in this research is arduino UNO with ATMEGA 328 microcontroller coupled with Ethernet shield as a connect arduino to the computer network (Fadilah, 2012). To make arduino for a webclient, arduino should dicoding then advance in accordance with the procedures to be coding arduino for webclient that can transmit data from current censor circuit to the server and all the data sent by the current censor circuit will be stored in the database.

## 2.3 Design of Software

In the design and manufacture of software in this study, the current censor communication with the microcontroller and the entire process using the C language software arduino IDE. While on the microcontroller communication with the server using PHP programming language to be sent and stored in the database using PHP application MyAdmin, this application is displayed via a web browser using PHP software, Ajax and Java script.

### 2.3.1 Flowchart Software

The following Figure 2 is a flow diagram in the software program

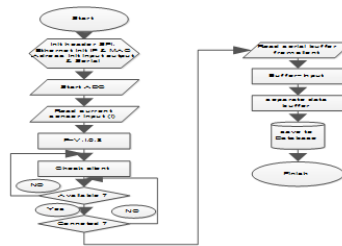

Figure 2: Flowchart Software

From the flow chart above can be explained, first performed declaration Ethernet, IP and MAC address of the ethernet shield and baud serial 9600. The data from the sensor is in the analog data form, thus arduino which has a ADC series (Analogue Digital Converter) will convert the analog data to digital data to be displayed on the analog read serial. Besides to read and display the serial value of the load current read, arduino UNO is a means of control of the results is issued, where the read current value will be multiplied by the ADC. The formulation which multiply to the ADC obtained from regression theory, so that the value of the square of the data errors to a minimum, so that even though there will be differences of each increment of data, after which is given the formula can be approached precision. Using the comparison data source between the measured data by data ampere pliers tool and data of current censor readings. Which has been converted and then inserted into the equation of the active data :

$$P = V.I. \cos \theta (kW) \quad (5)$$



Table 2: The Test of Current sensor

Number of lights (pcs)	Power (Watt)	ADC Data	Measured Current with plier Ampere (A)	Measured Current with sensor (A)	Error
No load	0	512	0	0	0
1	100	533	0.15	0.2	0.05
2	200	561	0.61	0.6	-0.01
3	300	592	1.02	0.98	-0.04
4	400	626	1.5	1.48	-0.02
5	500	663	1.82	1.8	-0.01

Where V is the voltage grid = 220V, while cos angle between current and voltage = 0.8. After that, the serial data from each phase R, S and T are sent to the database via the ethernet shield.

### 3 RESULTS AND DISCUSSION

Based on the specifications and work systems described earlier, then further testing of the system. The purpose of this test is to determine whether the systems that have been made are in accordance with previous plans.

#### 3.1 Current Sensor Testing

Testing to the results of current sensor readings with measured current using a measuring tool pliers ampere. The purpose of this test is to determine the accuracy of the sensor to the measured electrical quantities. To determine the error deviation between the sensor readings data and the measured data at measuring tool pliers ampere, used the following equation :

$$Error(\%) = \frac{\text{Difference between the sensor value and measuring instrument value}}{\text{measuring instrument value}} \times 100\% \quad (6)$$

The result of Current sensor test can be seen in Figure 3 and Table 2 below



Figure 3: The result of Current sensor test

From the measurement results can be seen, that the average value of the resulting error is small enough so that the current sensor design fit for use.

#### 3.2 The Testing Results Overall

This system testing conducted in the room of microprocessors laboratory, Padang State polytechnic. This system is built with the database server located in the room of the puslabkom Padang State polytechnic and webclient. Untuk webclient used arduino UNO AT-MEGA 328 coupled with the current sensor circuit and Ethernet shield which serves to

Table 3: Phase Power data R, S and T

load attached	Power (Watt)		
	R	S	T
No Load	0	0	0
AC On 1 pcs	625	192,24	6.1
AC On 2 pcs	1042.67	173,84	6.1
PC On 4 pcs	15.107	192,24	529,55
Lecturers room Lamp On	15.1	173,84	6.1
Practising room Lamp On	15.1	173,84	6.1
Technicians room Lamp On	15.1	173,84	6.1

connect the arduino to the computer network, so that all the data captured by the sensor circuit current in each phases R, S and T can be submitted online and are stored in the database server to be analyzed.

The test of arduino as a webclient using the HTTP protocol, arduino successfully used as a webclient, evidenced by looking at the existing database on the server. When arduino, ethernet shield and circuit power current sensors transmit data on phases R, S and T, the data will go directly to the database server and displayed in a web browser in real time. Views from the web browser and its database can be seen in Figure 4. For graphs of arduino as webclient can be viewed by accessing URSL: <http://kontrol.polinpdg.ac.id/tigaphase/fgrafik>



Figure 4: web browser GUI Display acquisition phase power R, S and T in the microprocessor laboratory

In figure 4 above views the data sent by the arduino as webclient. On the label appears the date, time and total power consumption. For the blue graphic is power data R, graphic black is power data S while the green graph is the power of T. Based on the chart above can be a data phase power R, S and T is sent to the web browser, which served into table 3

In the laboratory of microprocessor attached 2 pieces AC, Computer in practising room and lighting in the lecturers room, technicians and practising room. From the data of table 3 above can be seen that the air conditioning in the laboratory room microprocessor connected to phase R, computers in the practising room connected in phase T while the lights in the room are not connected to the panel room. Look no unbalanced load on each phase R, S and T. The data shown in the web browser will not appear immediately, because data is first entered into the database, then the data will be parsed into a web browser, the data phase R, S and T in the database PhpMyadmin can be seen in the picture below.

In the table 4 above, shown power on phase the R, S and T are sent to the database, table 4 shows the data that is sent to the web browser same with existing data in the database, there are : the phase R = 1042.67, S = 192.24 and T = 529.55, with testing 2 pieces air conditioner are on, 4 pieces personal computers are on, all the lamps in technicians, lecturers and practising room are turn on. The data on this database PhpMyadmin that will be parsed into a web browser to display a graph form.

Table 4: Display Database in Server

id	tgl	waktu	r	s	t
1	1/10/2014	13.26.51	1042.67	282.19	545.91
2	1/10/2014	13.26.54	1042.67	192.24	529.55
3	1/10/2014	13.26.57	1042.67	224.95	529.55
4	1/10/2014	13.27.04	1042.67	93.03	531.6
5	1/10/2014	13.27.57	1042.67	173.84	550
6	1/10/2014	13.27.57	1042.67	100.25	558.17

To test arduino as webclient is successful because arduino as webclient has successfully transmit power in phase R, S and T are captured by the current censor circuit to be sent to the server, which then power the data on phase R, S and T will be displayed to the web browsers in the form of graphs.

#### 4 CONCLUSION

The conclusion from this research are as follows. The test of arduino become HTTP-based webclient was successful, proven with the power of data on phases R, S and T, each of which uses a flow sensor of this research is done, it can be sent by arduino to the server, evidenced by power data in phase R, S and T on the arduino is phase R = 1042.67, S = 192.24 and T = 529.55 sent to the web server and the data stored in the database.

#### References

- Arif Fadilah. (2012). The Data Akuisisi System Design Based at BaseTransmissionS tation (BTS) PT. TELKOMSEL. *Thesis*. Padang: undergraduate Andalas University.
- Cataliotti A. and Cosentino V., (2010), A PC-based wattmeter forhigh accuracy power measurements, Instrumentation andMeasurement Technology Conference (I2MTC), *IEEE14531458*
- D. Al. Katsaprakakis, D.G. Christakis, A. Zervos and S.Voutsinas, (2008), A Power Quality Measure,*IEEE Transactions on Power Delivery*, 23(2)
- Influence of Instrument Transformers on Quality ofElectrical Power and Energy,(2007), Measurement Industrial Electronics, *ISIE IEEE International symposium*.
- Open Energy, (2014), CT sensors - Interfacing with an Arduino, *www.openenergymonitor.org*, accessed August 07, 2014
- Srividyadevi P., Pusphalatha D.V. and Sharma P.M, (2013), Measurement of Power and Energy Using Arduino ,*Research Journal of Engineering Sciences* Vol. 2(10), 10-15
- Suryatmo,F. (1997), *Teknik Pengukuran Listrik dan Elektronika*. Jakarta:Bumi Aksara
- Yousry Atia ,Mahmoud Salem, (2013), Microcontroller-Based Improved Predictive Current Controlled VSI for Single-Phase Grid-Connected Systems, *Journal of Power Electronics*, Vol. 13, No. 6, pp. 1016-1023

# History of Indonesian Independence Learning Media Using Interactive Story Telling For Elementary Schools Based on Android Platform

Yuliana Nyonata, T. Arie Setiawan Prasida,  
Birmanti Setia Utami

Satya Wacana Christian University

e-mail:yuliana.nyonata@gmail.com, arie\_setiawan\_p@yahoo.com, birmanti@gmail.com

## *Abstract*

*The development of a country can be seen from various aspects, one of them is the educational aspect. Education is also one of the main aspect to create qualified human resources. On the other hand, the technology continues to evolve rapidly from a variety of fields. One of them is the field of education. Social Science Lesson is one of the factors that affects education world. Particularly, history lesson is a lesson that is often considered dull and unattractive. It can not be denied, because until now the methods used are still the same and monotonous, one of them is the history of the Indonesian Republic Independence. There are many primary school students that do not understand much about historical lesson, therefore that event is very important to be understood. Therefore a new interactive and very interesting learning media by using picture books media is needed. Applications built by using prototype method, testing each step, until the results according to user requirements. The results can also help to increase childrens attractiveness to read and to know more about the history of the independence of the Indonesian Republic.*

**Keywords :** *Android, History, Independence, Interactive Story Telling, Prototype*

## 1 INTRODUCTION

Education is the main thing in building a developed nation. Quoting the Nobel Prize winner in economics, Professor Amartya Sen, the President stated prerequisite progress of a nation lies in the education and health sectors. "Education is the most appropriate way to eradicate poverty, expanding the middle class and build modern Indonesia in the 21st century", said President Bambang Yudhoyono (Kompas, 2014).

In education, there is a wide range of subjects that can be studied by the students. For example: Natural Sciences, Bahasa, Mathematics, Social Sciences, and many more. Basically, all subjects are important to be learned by the students but some subjects are often overlooked by students for example, social studies lesson.

Since 1915 the US education experts concluded that social studies consisting of several disciplines, such as history, geography, economics, and others will be taught simultaneously to equip learners to recognize and understand the social problems that exist in the surrounding (Kompasiana, 2012).

The many benefits require learners to study history. The importance of studying history is, because of the human condition that exists today is the result of past events (Sosiosejarah, 2013). For instance, a country independence day event. The current state of the Indonesian state is a state that is independent and free from various colonies of other countries. The glorious Independence of Indonesian to this day came through from the struggle of national patriots to achieve an independent state. The struggle that should not be forgotten by the people of Indonesia, especially learners.

But often found that students feel bored, sleepy, and bored to learn the science of history because the media used is relatively less (Nilawati, 2013). Yet according to the results of interviews conducted with elementary social studies teacher Kristen Satya Discourse, Salatiga, many students are more understand about the field of technology, art, and science lessons. The medium used to convey the history of science is still in the form of printed books.

Where students have to memorize any events that have occurred in the past. Another alternative that can be used is to invite students visited museums or historic sites. According to professor of history, University of Indonesia Susanto Zuhdi, teaching methods should be designed in such a way as to make it more fun (Zuhdi, 2012). Therefore a new technology is needed to make study process more fun, with the use of interactive and interesting study media.

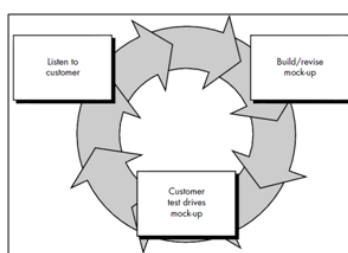

Figure 1: Prototype Method Char(Pressman, 1992)

The development of science and technology today allows users to obtain information and as a communication tool in many fields. One of the current technological developments is smart phones. It is powered by the Android operating system that is increasingly global. Based on a survey conducted by Gartner Android operating system is an operating system on smart phones that have the largest market share, with sales of 78.4%. With a free license, also received support from the hardware developers are increasingly supporting the development of software (Gartner, 2014).

Various software can be applied to the Android smart phone. One of them is in the field of education. Software on Android smart phones in the field of education commonly referred to as mobile learning (Georgiev et al., 2004). Mobile learning is a media of learning in which learners are not stand still at one place but it is learning activities that take advantage of mobile technology devices (O'Malley, 2003). The use of Android smart phone is the

most effective media to provide a different experience in the learning process because it can be accessed anywhere and anytime. Therefore Android smart phone use is very suitable for increasing student interest to get more attracted on learning history.

## 2 RESEARCH METHODOLOGY

### 2.1 Multimedia

Definition Multimedia by Vaughan (2006) is a combination of text, photo, graphic art, sound, animation and video digitally manipulated and can be delivered and interactively controlled. According to Vaughan (2006) that the interactive multimedia form if the user can control what and when multimedia elements will be sent or displayed. Multimedia elements include: Text, Image, Sound, Video.

### 2.2 Animation



Figure 2: Gestures Tap

Understanding the animation is a process of recording and playing back a series of static images to get an illusion of movement (McGraw-Hill and Ibiz, 2002). Basically animation has some kind of one of them is a 2D animation. Animation 2D (two-dimensional) is the simplest animation (Vaughan, 2011).

### 2.3 Interactive Story Telling

Interactive story or interactive story telling or commonly referred to as the IS is a new device that allows users to interact and participate in the story. IS utilize computers and pictures as well as interesting stories (Crawford, 2004). Therefore, the selection of an interesting story and the right media is able to make the children feel happy in learning.

### 2.4 Independence of The Republic of Indonesia History

According Numan Somantri the book Teaching Civics say Social Sciences (IPS) is an educational program that has educational material of social and humanity disciplines (science education and history) are organized and presented scientifically and psychologically for educational purposes based on Pancasila and culture Indonesia (Sumantri, 1976).

The importance of studying history is, because of the human condition that exists today is the result of past events (Sosiosejarah, 2013). An example is the independence of the Republic of Indonesia (RI). Before becoming an independent state, Indonesia is a country colonized other nations such as Japan and the Netherlands. This independence of events that should always be remembered, especially by the citizens of Indonesia. Important figures in the event of independence is Ir. Sukarno and Dr. Moh. Hatta. They along with Ahmad Soebardjo designing copy of the proclamation in Admiral Maedas house. The manuscript was then read and approved by the PPKI. A draft then typed by Sajuti Melik. When typing occurred three changes. Once the script is finished typed, then the script is signed by Ir. Sukarno and Dr. Moh.Hatta on behalf of the Indonesian nation. The manuscript that has been signed then read by Ir. Sukarno in his yard located at Pegangsaan East Street on 17 August 1945 at 10:00 a.m. After the reading of the text of the proclamation carried the red and white colored flag raising accompanied by the song Indonesia Raya.

## 2.5 Android



Figure 3: Main Menu GUI Design Results

Smart phone Android is amoving operating system (mobile) withmodification version from Linux. As a software, this system have superiority, that is software based on computer codethat can be distributedfreely, so programmerscanmakenew applications in it (Cooper, 2010).

## 2.6 Method

Design method used in this research is the prototype method. Prototype method is a method of designing the approach of the needs of users of the system.

Figure 1 shows the schematic of prototype method, the prototype method begin with listen to the customer stage which is an early stage of applications development. At this stage the data has been collected from research that has been doing on Satya Wacana Christian elementary school. The second stage is the stage of the build / revise mock-up that aims to define user requirements and obtain the information needed. To begin designing the system started with designing and implementing the system in the form of application. The final stage of the prototype method is the customer stage mock-up test drives. At this stage of the analysis carried out applications built to find application failures that may exist, is done by testing the application to children whose average was 5th grade elementary school. If there are deficiencies, then returned to the stage of the build / revisemock-up. This phase continue until the application according to user requirements.



Figure 4: Story Pages GUI Results

### 3 RESULTS AND DISCUSSION

This section will explain the results and discussion of instructional media interactive story based on data and design contained in Chapter 3. Learning media interactive story entitled "Tahoen '05" The title selection drew inspiration from the writing of the text of the proclamation that has been typed.

This interactive story telling study mediadesign will be applied on smart phone Android. Therefore, resolution to be used need to be noted. Resolution that will be used is 1280 x 720 pixel with 16 : 9 comparison. This comparison is a standard display size of Android smart phone with big resolution.

In Indonesian Republic Proclamation interactive learning media, users are granted access to fully control on the use of application. Through available menu user can interact directly with application to produce effects or reaction that will appear in the form of animation and audio. Users can use gesture tap on specific characters and choices on available menus. Gestures tap can be seen on Figure 2.

Adobe Air is an application that is used to operate flash digital technology devices such as desktop, laptop or mobile. Adobe AIR have the same function as Adobe Flash.

GUI implementation adapted to the concept and design elements. GUI design made based on the needs of the menu. The concept of main menu GUI was inspired from the flag wave with options menu located on the right side of the application. On this menu, there are two language choices, Bahasa and English language (bilingual). It can be seen on Figure 3.

Design on the story pages highlighting the animation that will be displayed, Animation made different on every page of the story. Story pages design can be seen in Figure 4.

Biography menu GUI design use red and white flag wave background. Biography menu background design use scrolling paper with a larger size. Biography menu GUI Design can be seen in Figure 5.



Figure 5: Biography Menu Design

GUI design tutorial menu similar to the menu biography. But in the animation displayed using digital images of Android smart phone. GUI design tutorial menu can be seen in Figure 6.





Figure 6: Tutorial Menu GUI Design

## 4 CONCLUSION

It can be concluded that the Interactive storytelling can be used as a medium of learning the history of independence of the Republic of Indonesia. Color, writing, and music used in this exciting learning media and according to user needs. In terms of interaction, the application is able to build a child's interest to see the object that gave rise to suppress any animation. The function of each key can be run properly. In terms of benefits, users who use instructional media applications can understand this interactive story about the events and actors historians independence of the Republic of Indonesia. In application development, there are suggestions that could be considered for future research such as the manufacture of other historical story, the addition of interaction such as additional mini-games, as well as development on various platforms other than Android.

## References

- Cooper, Martin. (2010). *Step by Step Smart Phone Android*. Massachusetts : Pace University.
- Crawford, C. (2004). *Chris Crawford on Interactive Story Telling*. New Riders Games, Indianapolis, IN.
- Fitriana, Irta. (2012). Pentingnya Bahasa Inggris dalam Pendidikan di Indonesia. <http://download.portalgaruda.org/article.php?article=116612&val=5316>, accessed : 04 February 2015.
- Gartner. (2014). Gartner Says Annual Smart Phone Sales Surpassed Sales of Feature Phones for The First Time in 2013, <http://www.gartner.com/newsroom/id/2665715>, accessed 29 June 2014.
- Georgiev, Tsvetozar, et al. (2004). M-Learning - a New Stage of E-Learning, <http://ecet.ecs.ru.acad.bg/cst04/docs/siv/428.pdf>, accessed : 30 December 2012.
- Kompas. (2014). Pentingnya Pendidikan di Indonesia, <http://edukasi.kompas.com/read/2014/08/15/164>
- Presiden.SBY.Pendidikan.Bukan.Sekadar.Mengirim.Anak.ke.Sekolah, accessed: 27 January 2015.
- Kompasiana. (2012). Pentingnya Mempelajari Ilmu Pengetahuan Sosial, <http://edukasi.kompasiana.com/2012/09/10/sejarah-ips-di-indonesia-485615.html>, accessed: 28 January 2015.

- McGraw-Hill, Ibiz Fernandez. (2002). *Macromedia Flash Animation & Cartooning: A creative Guide*, California : Osborn.
- Nilawati, Husni. (2013). Belajar Sejarah? Ah Membosankan, <http://www.republika.co.id/berita/jurnalisme-warga/wacana/13/03/16/mjqh0o-belajar-sejarah-ah-membosankan>, accessed : 01 February 2015.
- OMalley C., et al. (2003). Guidelines For Learning/Teaching/Tutoring in a Mobile Environment, <http://www.mobilearn.org/download/results/guidelines.pdf>, accessed : 29 August 2012.
- Pressman, Roger. (1992). *Software Engineering A practitioners Approach*, Mc-Graw-HillInc.
- Sosiosejarah. (2013). Manfaat Penting Sejarah, <http://www.sosiosejarah.com/2013/07/manfaat-penting-sejarah.html>, accessed: 28 January 2015.
- Sumantri, Moh. Numan. (1976). *Metode Pengajaran Civics*, Yogyakarta : Aditya Media.
- Vaughan, Tay. (2011). *Making It Work, 8th Edition*, Yogyakarta : Andi Publisher.
- Zuhdi, Susanto. (2012). Cara Menyenangkan Belajar Sejarah. <http://www.republika.co.id/berita/pendidikan/eduaction/12/10/17/mc17j3-cara-menyenangkan-belajar-sejarah>, accessed : 23 January 2015.

# A Type-2 Fuzzy Logic for Measurement of Meta-Management Success in Virtual Organisation

Muhammad Ridwan Andi Purnomo

Department of Industrial Engineering, Faculty of Industrial Technology  
Universitas Islam Indonesia  
e-mail:ridwan\_ie@uii.ac.id

## *Abstract*

*In Small and Medium Industries (SMI), in pursuit competitive advantages, one of the collaboration type commonly applied is temporary collaboration. The industries that are involved in a collaboration would arrange a contract so that such industries could work with common objectives. By the support of Information Technology (IT), temporary collaboration mostly was managed virtually and the involved industries form a Virtual Organisation (VO). In VO, the management called as meta-management, which provides a systematic approach to the exploitation of competitive economic advantages for the VO. It consists of basic activities including analysing and tracking requirements, allocating satisfiers to requirements, and adjusting the optimality criteria. In term of management improvement, there is lack mostly on success measurement that actually could be the basis of further improvement. This paper presents the use of Type-2 Fuzzy Logic (T2FL) for measurement of meta-management success. The success is measured based on aspects that have been mentioned above, and a T2FL is proposed to cope with uncertainties in every aspect. A numerical examples was solved to show how the proposed method works.*

**Keywords :** *Type-2 fuzzy logic, meta-management, success measurement, virtual organisation, uncertainty*

## 1 INTRODUCTION

Competitive market encourages industries to collaborate each other to pursuit competitive advantages. For Small and Medium Industries (SMI), besides collaboration, another important issue is flexibility . When the market demand is keep on changing, hence, one of the effort to be flexible is having temporary collaboration with other industries. The temporary collaboration enables an industry to have chance to collaborates with other companies dynamically. A contract would be arranged among involved industries in a collaboration so that such industries could work with common reference.

In a dynamic collaboration, information and knowledge would flow among involved industries fast. Hence, Information Technology (IT) support plays an important role in the

collaboration. When the involved industries use IT support to manage the collaboration, hence, a Virtual Organisation (VO) would be formed. Management system in a VO is called as meta-management, and, similar with conventional management, meta-management is also need to be analysed for further improvement. The analysis must be started from performance measurement of the meta-management, hence, a system to evaluate success score of the application of meta-management is urgently required.

Analysis about management would involves activity-based measurements. It could not be measured directly using some measurement tools. Hence, experts opinion would plays major role in analysing the data. In uncertainty condition, expert opinions would mix with uncertainty and vagueness. In engineering field, Fuzzy Logic (FL) is one of the established technique that could be used to model uncertainty and vagueness. FL was introduced by Zadeh in 1965 (Zadeh, 1965) and has been successfully applied in so many fields, such as engineering, operational science, management and so on. Parallel with the increase of problem complexity, FL also received positive critics from researchers. The conventional FL, called as Type-1 Fuzzy Logic (T1FL), models the uncertainty and vagueness of the input variables with fuzzy sets. However, the fuzzy sets in T1FL is still fix, there is no interval in the fuzzy curves so that sometime the fuzzy curves do not represent experts opinion. Some researchers proposed T2FL to accomplish T1FL in accommodating uncertainty and vagueness by applying interval fuzzy sets to fuzzify the input variables. This study tries to elaborate the used of T2FL to measure success score of meta-management in a VO.

## 2 RELATED WORKS

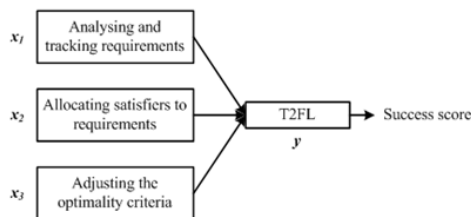

Figure 1: Model for success meta-management measurement

Several studies on VO and meta-management has been conducted by previous researchers. However, in our knowledge, there is still no study about success measurement for the meta-management in VO. In term of management improvement, such measurement could be the basis of evaluation. Following sections discover several previous studies on development of VO and meta-management.

Khalil and Wang (2002) elaborated that Information Technology (IT) plays major roles in VO. In electronic commerce era, virtualisation will make companies to have cross-boundaries organisation, automatic work flow and lower transaction cost and marketing. Such advantages raises the complexity in VO and IT could be one of the tool to manage the complexity. Basic activities of meta-management have also elaborated and the role of IT in supporting them. Such basis activities would be the basis of the inputs to evaluate success of meta-management in this study.

Manring and Moore (2006) investigated a model for managing a virtual inter-organisational learning network for greener production. The dimensions used for green company evaluation are ecological, economic and social and the stakeholders are textile production chain, their local and provincial communities, regulators and policy makers. Such study shows that the proposed model could be used as learning tool for MBA students in learning green company management. Indirectly, such study also shows that success of green company could be achieved from team learning through virtual organisation.

In microscopic level of meta-management, Lin et al. (2010) established a model by drawing from key postulates and findings under cooperation to explain the formation of perceived job effectiveness in team collaboration. The goal is to evaluate perceived job that influenced directly by knowledge sharing, cooperative attitude, and competitive conflict, while knowledge sharing is influenced by cooperative attitude and competitive conflict. Perceived job effectiveness is also influenced indirectly by shared value, perceived trust and perceived benefit via the mediation of cooperative attitude and competitive conflict. The study also elaborates managerial impact from the result.

Management evaluation, usually conducted based on interview and or questionnaires distribution and the result is subject to the respondent's perceptions. Hence, the result could be mixed with uncertainty and vagueness. Those factors are very hard to be incorporated in exact analysis method, such as mathematical model or algorithm. One of the formal methods that could be used to represent uncertainty and vagueness is Fuzzy Logic (FL). In the Type-1 FL (T1FL), uncertainty and vagueness is represented by a Fuzzy set instead of a Crisp value. The Fuzzy set has tolerance to accommodate the uncertainty and vagueness. However, there are several positive criticisms for T1FL when representing the uncertainty and vagueness. A curve line in T1FL represents a single value of membership and it does not deal with uncertainty and vagueness. Hence, T2FL has received major attention from researchers to be used to represent uncertainty and vagueness.

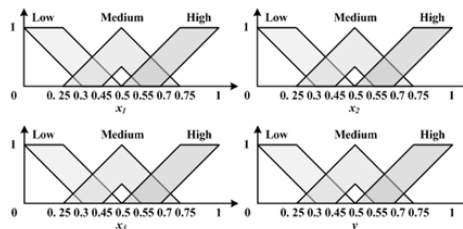

Figure 2: Fuzzy set for every input and output variable

Mendoza et al. (2009) investigated the application of T2FL which combined with modular Artificial Neural Network (ANN) for pattern recognition case, that is face recognition. There are 2 T2FL applied, the first T2FL was used for feature extraction in the training data while the second T2FL was used to predict the relevance of the modular ANN as the recognition module. Such study shows that FLT2 could increase the performance of modular ANN by facilitating the representation of human expert perceptions. Miller and John (2010) investigated the application of T2FL for multi echelons supply chain modelling. The FLT was used to model several parameters in the supply chain such as forecast demand, inventory level, transportation distances, transportation cost, stock out level, stock out cost, carry over and

Table 1: Fuzzy rules

R	Fuzzy rule	R	Fuzzy rule
1	x1: Low AND x2: Low AND x3: Low y: Low	15	x1: Med AND x2: Med AND x3: Hi y: Med
2	x1: Low AND x2: Low AND x3: Med y: Low	16	x1: Med AND x2: Hi AND x3: Low y: Med
3	x1: Low AND x2: Low AND x3: Hi y: Low	17	x1: Med AND x2: Hi AND x3: Med y: Med
4	x1: Low AND x2: Med AND x3: Low y: Low	18	x1: Med AND x2: Hi AND x3: Hi y: Hi
5	x1: Low AND x2: Med AND x3: Med y: Med	19	x1: Hi AND x2: Low AND x3: Low y: Low
6	x1: Low AND x2: Med AND x3: Hi y: Med	20	x1: Hi AND x2: Low AND x3: Med y: Med
7	x1: Low AND x2: Hi AND x3: Low y: Med	21	x1: Hi AND x2: Low AND x3: Hi y: Hi
8	x1: Low AND x2: Hi AND x3: Med y: Med	22	x1: Hi AND x2: Med AND x3: Low y: Med
9	x1: Low AND x2: Hi AND x3: High y: Hi	23	x1: Hi AND x2: Med AND x3: Med y: Med
10	x1: Med AND x2: Low AND x3: Low y: Low	24	x1: Hi AND x2: Med AND x3: Hi y: Med
11	x1: Med AND x2: Low AND x3: Med y: Low	25	x1: Hi AND x2: Hi AND x3: Lo y: Med
12	x1: Med AND x2: Low AND x3: Hi y: Med	26	x1: Hi AND x2: Hi AND x3: Med y: Hi
13	x1: Med AND x2: Med AND x3: Low y: Low	27	x1: Hi AND x2: Hi AND x3: Hi y: Hi
14	x1: Med AND x2: Med AND x3: Med y: Med		

holding cost. For decision variables optimisation, a Genetic Algorithm (GA) has been used. Such study shows that T2FL has better performance in representing uncertainties compared to T1FL.

Fazel Zarandi et al. (2012) applied T2FL for prediction case, that is carbon monoxide concentration forecasting. In such study, footprint of uncertainties of Fuzzy sets are extracted by implementation of an interval type-2 Fuzzy C-Means (FCM) algorithm and based on an upper and lower value for the level of fuzziness  $m$  in FCM. The study shows that T2FL has superior performance in comparison with T1FL.

Based on the literatures survey above, it could be understood that T2FL has potentiality to be used for measurement of a meta-management success. The following sections would elaborate in detail the application of T2FL in modelling meta-management success measurement.

### 3 RESEARCH METHODOLOGY

In order to explain the modelling of meta-management success in a VO, a numerical example is given as in the following section. The diagram of meta-management success measurement is shown in Figure 1.

This study is using Mamdani style FL and the first step is fuzzification, Such step is carried out by providing fuzzy sets for every input and output variable. In order to get uniform scale for every variable, then normalised data is used to develop the fuzzy sets. Figure 2 shows the fuzzy set for every input and output variable. In T2FL, every fuzzy curve has an interval to cope with uncertainty and vagueness. That's why T2FL has superior performance in accommodating uncertainty and vagueness compared to T1FL. The fuzzy rules are shown in Table 1. All of fuzzy sets and rules are defined by expert.

For further analysis, an input vector is required. Let say, an input vector of  $\{0.7, 0.75, 0.8\}$  is obtained from questionnaires data processing, then following analysed could be carried out. It is different from T1FL, in T2FL, since there is an interval in every fuzzy curve, when evaluating an input vector using Fuzzy rules, there will be two membership value, called lower ( $\underline{f}$ ) and upper membership value ( $\overline{f}$ ). In this study,  $y$  (output) is assumed at the middle point of the fuzzy set. For instance, R1,  $y$  is low, it means that the lower and upper membership

Table 2: Firing of every fuzzy rule (non-zero result only)

Rule	Firing interval	Consequent
R18	[0, 0.2]	[0.5, 1]
R27	[0, 0.8]	[0.5, 1]

value is find based on  $y = 0.125$ . Hence,  $y^1 = 0.5833$  and  $\overline{y^1} = 1$ . Membership value for every input value in every fuzzy set is shown as follows while Table 2 shows firing of every fuzzy rule.

$$\begin{aligned}
[\underline{\mu_{x_{11}}}(0.7), \overline{\mu_{x_{11}}}(0.7)] &= [0, 0] \\
[\underline{\mu_{x_{12}}}(0.7), \overline{\mu_{x_{12}}}(0.7)] &= [0, 0.2] \\
[\underline{\mu_{x_{13}}}(0.7), \overline{\mu_{x_{13}}}(0.7)] &= [0, 0.8] \\
[\underline{\mu_{x_{21}}}(0.75), \overline{\mu_{x_{21}}}(0.75)] &= [0, 0] \\
[\underline{\mu_{x_{22}}}(0.75), \overline{\mu_{x_{22}}}(0.75)] &= [0, 0] \\
[\underline{\mu_{x_{23}}}(0.75), \overline{\mu_{x_{23}}}(0.75)] &= [0.2, 0.1] \\
[\underline{\mu_{x_{31}}}(0.8), \overline{\mu_{x_{31}}}(0.8)] &= [0, 0] \\
[\underline{\mu_{x_{32}}}(0.8), \overline{\mu_{x_{32}}}(0.8)] &= [0, 0] \\
[\underline{\mu_{x_{33}}}(0.8), \overline{\mu_{x_{33}}}(0.8)] &= [0.4, 1]
\end{aligned}$$

Since there are still 2 values in firing of every rule, then the next step is defining switching point from upper to lower firing (L) and from lower to upper firing (R). In this study, Karnik-Mendel (KM) algorithm was applied to define the switching points. See Mendel (2001) for detail explanation of KM algorithm. Based on the KM algorithm, it is found that  $L = R = 18$ , and following defuzzification could be conducted.

$$y_l = \frac{((0.2x0.5) + (0x0.5))}{0.2 + 0} = 0.5$$

$$y_r = \frac{((0x1) + (0.8x0.1))}{0 + 0.8} = 1$$

$$y = \frac{0.5 + 1}{2} = 0.75$$

Hence, the success score for the investigated meta-management in a VO is 0.75.

#### 4 DISCUSSIONS

In T2FL, the use of interval fuzzy sets makes the T2FL more acceptable by the experts. However, analysis in T2FL will be more complicated compared to T1FL since there will be two membership value for every input variable. Output domain resulted by inference system in T2FL will be an interval. Therefore, a technique to reduce the fuzzy type, which is from type 2 to be type 1, is required. So far, there is no formal method for reducing the fuzzy type, and in this study, KM algorithm is applied for that objective. Based on the numerical

example above, it is proven that the KM algorithm can be considered as one of the method to reduce the fuzzy type.

FL with Mamdani style uses experts opinion for modelling. Output validation will be carried out subjectively by the experts. Scientifically, there is no reference point to verify the result and so far there is no formal method to verify the result. However, result verification could be conducted based on the acceptance of the solution. In the numerical example above, value of every input variable is slightly high, even though the value is not the maximum value. Logically, the success score of the meta-management in the investigated VO must be relatively high as well. The proposed T2FL produces 0.75 as the success score and it is reasonable. Hence, it could be justified fairly that the result is valid.

## 5 CONCLUSION AND SUGGESTION

Based on the explanation above, it could be concluded that T2FL could be used to model uncertainty and vagueness in measurement of meta-management success in a VO. Interval in the fuzzy set could be used to accommodate the uncertainty and vagueness that is mixed in the input and output variables. The proposed T2FL also able to produce reasonable result.

Suggestions for further study is, it is recommended to hybrid an optimisation algorithm such as Genetic Algorithm (GA) with the T2FL. The hybridisation could be used to optimise parameter value in the fuzzy sets and to optimise the fuzzy rules when the T2FL being used to model supervised system.

## References

- Fazel Zarandi, M.H., Faraji, M.R. and Karbasian, M. (2012). Interval type-2 fuzzy expert system for prediction of carbon monoxide concentration in mega-cities, *Applied Soft Computing*, 12, 291-301.
- Khalil, O. and Wang, S. (2002). Information technology enabled meta-management for virtual organizations, *Int. J. Production Economics*, 75, 127-134.
- Lin, C.P., Wang, Y.J. Tsai, Y.H. and Hsu, Y.F. (2010). Perceived job effectiveness in cooperation: A survey of virtual teams within business organizations, *Computers in Human Behavior*, 26, 1598-1606.
- Manring, S.L. and Moore, S.B. (2006). Creating and managing a virtual inter-organizational learning network for greener production: a conceptual model and case study, *Journal of Cleaner Production*, 14, 891-899.
- Mendel, J.M. (2001). *Uncertain Rule-Based Fuzzy Logic Systems: Introduction and New Directions*. Upper Saddle River, NJ: Prentice-Hall.
- Mendoza, O., Melin, P. and Castillo, O. (2009). Interval type-2 fuzzy logic and modular neural networks for face recognition applications, *Applied Soft Computing*, 9, 1377-1387.
- Miller, S. and John, R. (2010). An Interval Type-2 Fuzzy multiple echelon supply chain model, *Knowledge-Based Systems*, 23, 363-368.
- Zadeh, L.A. (1965). Fuzzy sets, *Information and Control*, 8, 338-353.



# Audio/Video Bridging (AVB) Protocol for Industrial Application

Syamsul Rizal, Dong-Seong Kim

School of Electronic Engineering  
Kumoh National Institute of Technology  
e-mail:(syamsul, dskim)@kumoh.ac.kr

## *Abstract*

*In Industrial Real-Time Systems, data rate and latency are important factors. Many researchers discuss the industrial protocols to robust Industrial network performances. CAN Bus is one of protocol which is used in industrial application. CAN Bus is develop for Industrial Automation Systems interest. It designed to al low MCU (Micro-Control Unit) and other devices to communicate each other without host computer. Nowadays CAN Bus also be used as fieldbus in automation environment. In CAN Bus network, if the main cable is damaged t hen the networks will fail or be split into two networks. The other protocol which is suitable for Industrial Automation Systems is Audio/Video Bridging (AVB) protocol. IEEE 802.1BA is the Audio/Video Bridging (AVB) standard for transporting audio, video, or the other real-time data through ethernet. AVB network can reserved bandwidth for critical information. One aspect of this standardization effort is to adapt AVB stream reservation mechanisms to operate with industrial-standard. This thesis proposed the AVB mechanism to achieve low latency in industrial network and compared with CAN Bus protocol.*

**Keywords :** *Audio/Video Bridging, Industrial Application, Real-Time Systems*

## 1 INTRODUCTION

In industrial application (Quang, 2012) real-time delivery is important. It contains of the number of sensors, actuators, and I/Os. (Choi, 2008), (Nhon, 2015) The time-sensitive traffic requires three main functions. First, precise timing and synchronization is needed so that individual traffic streams will meet their respective jitter, and time synchronization requirements.

The Audio/Video Bridging (AVB) (Szurman, 2014) is one of proto col which is used for time-sensitive traffic over IEEE 802 bridged networks. It can reserve the source bandwidth for the real-time data such as Audio, Video, or the others. Ethernet AVB is a set of standards, providing quality of service (QoS) mechanisms for low latency communication. Several IEEE standard was adding to achieve the QoS requirements for low latency streaming in Ethernet

network. With AVB, Industrial Real-Time Ethernet will be able to leverage all of the advantages. These functions (Geyer, 2013, Garner, 2011) are provided by three AVB standard: IEEE 802.1AS (precise timing and synchronization), IEEE 802.1Qat (Stream Reservation Protocol (SRP)), and IEEE 802.1Qav (Forwarding and Queuing Enhancements for Time-Sensitive Streams). All of these standards will be used to make AVB network in this paper work. This work describes a configuration mechanism to achieve low latency in industrial network. The CAN Bus protocol is used as comparison with AVB protocol.

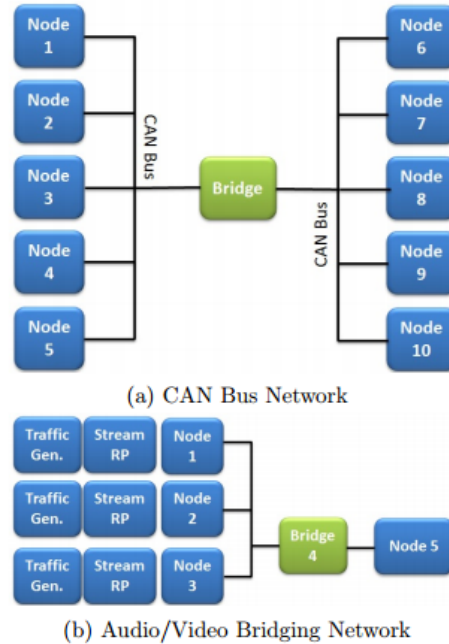

Figure 1: System Model

## 2 SYSTEM MODEL

### 2.1 CAN Bus Network Model

A simple CAN network contains of source node, CAN Bus, Bridge, and destination node. 10 nodes is used in this simulation model, as shown in figure 1a. CAN Bus arbitrates for each sensor based on ID (IDENTIFIER) of message, where lower can win. If CAN Bus is busy, then port will buffer sensor data, else process.

### 2.2 Audio/Video Bridging Network Model

The AVB system can include the talkers and listeners such as video cameras, radars, broadcast systems, etc. The network can include AVB interfaces, bridges, switches, and gateways. System model for this simulation can be seen in figure 1b.

Each node consist of one Traffic Generator, StreamRP, and Node Block. The bridges the AVB Bridge block. A node 5 is listener, the output of this block is connected to the AVB

Stats to measure the latency. Figure 2 is the process how the AVB networks reserved the bandwidth and transmit the stream. Talker sends TalkerAdvertise message to the bridges. The bridges which is receiving the TalkerAdvertise message check for bandwidth availability. The required bandwidth of the streaming data (StreamBW) at each node of intermediates bridges is calculated by using equation 1.

$$StreamBW = \frac{(MSF + OH).MIF}{IntervalTime} \quad (1)$$

MaxFrameSize (MFS) indicates the maximum payload size of each frame transporting the stream while MaxIntervalFrames (MIF) in each interval time (Kim, 2008, Choi, 2010). The OverHead (OH) is 42 bytes and includes the Ethernet header, preamble, and CRC. After the streamBW is calculated and the output port of switch has enough resource, the frame is forwarded without any modifications to the port. In the other case, when no sufficient resources are available, the frame is modified to talker failed frame with failure information. When the bridge has got sufficient resources available on that port, then the TalkerAdvertise is propagated to the next bridge/node. If the resource is not available, the bridge will send a TalkerFailed message. This message contains of failure code and bridge identification to provide error checking or notification.

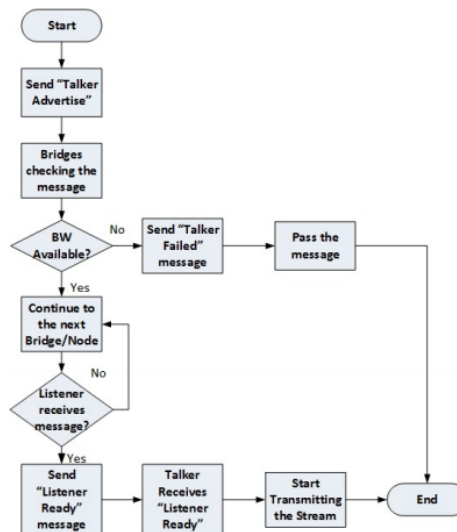

Figure 2: AVB Bandwidth Reservation Flowchart

The bridges which is receiving TalkerFailed message, will drop the message. When the listeners receives a Talker Advertise message, it will respond with ListenerReady message that is forwarded back towards the talker. The bridges use the ListenerReady message to lock down the resources needed by the stream. When the talker receives a ListenerReady message, it can start transmitting the stream. The talker can de-registering the stream by sending the de-registration message through the network in the same manner as the registration stream.

### 3 RESULTS AND ANALYSIS

This work is focused on designing an Audio/Video Bridging Protocol in Industrial Application environment and compared it with CAN protocol. In industrial application the end-to-end delay must be small to get good network performance.

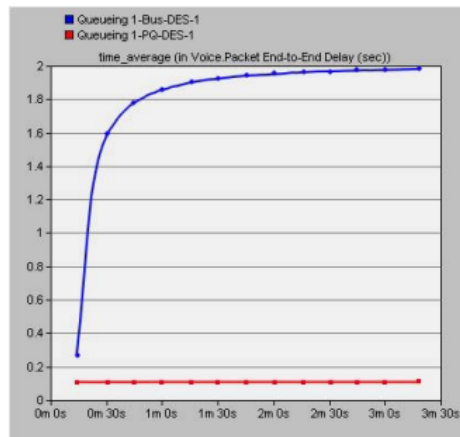

Figure 3: End-to-End Delay

Figure 3 shows the time average for end-to-end delay to transmit voice stream. AVB protocol end-to-end delay is smaller than CAN Bus protocol. It is because in AVB network, the bandwidth has been reserved for voice stream, so the average time is stable around 0.1 second.

One of the metric which is used in this paper is Queuing Delay. Queuing delay in AVB (Red line) network is smaller than CAN (Blue line) network. AVB network need around 2.7 ms and 3.0 ms for CAN network for queuing the packets as shown on the figure 4. It happen because in the AVB network used Priority Queuing Scheduler. The queuing delay in the AVB network can be small by reduce the reservation bandwidth for audio or video stream.

### 4 CONCLUSION

This paper designed the Audio/Video Bridging (AVB) to enhanced the industrial network performances. The AVB using Reserved Streaming Protocol (RSP) to reserved the bandwidth for real-time content in the network. CAN protocol is standard which is used for industrial application. Because of that reason, CAN network has been simulated as comparison with AVB network.

The AVB network is suitable is industrial application on the other real-time applications such as automotive. The performances using AVB protocol are better than CAN protocol. These are happened because in AVB protocol need to reserved bandwidth/resource before start the transmission. Simulation result shows that AVB has smaller end-to-end delay, and queuing delay.

For further research, this study will be implemented the AVB protocol in wireless application. Because nowadays, the AVB support for ethernet only.

## References

- D.H. Choi, and D.S. Kim. (2008). Wireless Fieldbus for Networked Control Systems using LR-WPAN, *International Journal of Control, Automation, and Systems*, Vol. 6, No. 1, 119125.
- Geyer, F., Heidinger, E., Schneele, S. and von Bodisco, A. (2013). Evaluation of Audio/Video Bridging forwarding method in an avionics switched ethernet context, *IEEE Symposium on Computers and Communications*, 711716.
- G..M. Garner and H. Ryu. (2011). Synchronization of Audio/Video Bridging Networks Using IEEE 802.1AS, *IEEE Communications Magazine*, Vol. 49, No. 2, 140147.
- K. Szurman, L. Miculka, and Z. Kotasek. (2014). State Synchronization after Partial Re-configuration of Fault Tolerant CAN Bus Control System, *17th Euromicro Conference on Digital System Design*, 704707.
- M.-J. Kim, T.-S. Jang, M.-S. Jung, and S.-H. Kim. (2008). Frame Forwarding Rules for Link Utilization in IEEE 802.1 AVB Networks, *International Conference on Advanced Language Processing and Web Information Technology*, 509512.
- P. Quang, and D.S. Kim. (2012). Enhancing real-time delivery of gradient routing for industrial wireless sensor networks, *IEEE Transactions on Industrial Informatics*, Vol. 8, No. 1, 6168.
- T. Nhon, and D.S. Kim. (2015). Real-Time Message Scheduling for ISA100.11a Networks, *Computer Standards & Interfaces*, Vol. 37, 7379.
- Y.-D. Choi, J.-H Jun, G.-B. Kil and S.-H. Kim. (2010). Bandwidth Reservation Method to Consider Reservation Failure in VLAN, *International Conference on Broadband, Wireless Computing, Communication and Applications*, 175180.

## New Pheromone Updating Mechanism for Ant Colony Optimization in Designing DNA Sequence

T.B.Kurniawan, Misinem, M.Z. Ahmad Nazri

Universitas Bina Darma

e-mail: tribasukikurniawan@yahoo.com

Universitas Bina Darma

e-mail: misinem\_kurniawan@yahoo.com

UnivesitiKebangsaan Malaysia

e-mail: zakree@ukm.edu.my

### *Abstract*

*DNA computing is relatively a new computing paradigm that uses bio-molecular as information storage media and biochemical tools as an information processing operators. Hybridization between a DNA sequence and its base-pairing complement is crucial to retrieve the information stored in DNA sequence and operate a computation operation in DNA computing. Since DNA reactions are probabilistic reactions, it can cause different results for the same situation, which can be regarded as error in computation. To overcome the drawbacks, this paper proposed an Ant Colony System (ACS) that uses four nodes model to represent four DNA bases. In this model, the nearest-neighbor thermodynamic parameters Watson-Crick base pair  $\Delta G_{037}$  is used as the distance between nodes. Although the results are comparable to other approaches, the obtained DNA sequences tend to repeat the same pattern in some DNA bases. In this paper, hierarchical pheromone updating method for ACS is proposed. The obtained results from new approach were compared with the previous approaches and show a relative better pattern results.*

**Keywords :** *Ant Colony Optimization (ACO), Ant Colony System (ACS), DNA Sequence Design, Hierarchical Pheromone Updating Strategy, and Thermodynamic*

## 1 INTRODUCTION

The main objective of DNA sequence design is to prevent mismatch hybridization among sequences in the data set. Avoidance of mismatch hybridisation ensures that the generated DNA sequences are unique and cannot be hybridised with other sequences. Previous studies have proposed a variety of DNA sequence design approaches (Brenneman and Condon, 2002; Shin et al., 2005) and applications of DNA sequence design can be seen in several areas (Hertemink et al, 1998; Ponchovsky and Ackermann, 2003; Frutos et al., 1997; Feldkamp et al., 2001; Tanaka et al., 2001; Marathe et al., 1999; Deaton et al., 2002; Zhang and Shin, 1998).

In Kurniawan et al. (2008), an Ant Colony System (ACS) as a derivative from Ant Colony Optimization (ACO) which uses four nodes model to represent four DNA bases was proposed as shown in Figure 1. The ACS uses the nearest-neighbor thermodynamic parameters Watson-Crick base pair  $\Delta G_{\circ 37}$  as the distance between nodes. Although the results are comparable to other approaches, the obtained DNA sequences tend to be repeating only in some DNA bases as shown in Figure 2. This pattern makes a generated DNA Sequence difficult to fulfill the constraints in DNA Sequence Design Problem. Since the solution is consider as a set of DNA Sequences, if there are one of DNA sequence in that set fail to fulfill the constraint, the set of DNA Sequences cannot be accept as a candidate of solution. In order to overcome this problem, this paper proposed a new pheromone updating strategy. This paper is organized as follows. In section 2, the DNA sequence design problem is defined and proposed approach is discussed in detail, Section 3 the sequence generation results are shown and compared with those of other existing methods and analysis is discussed. In Section 4, conclusion is drawn.

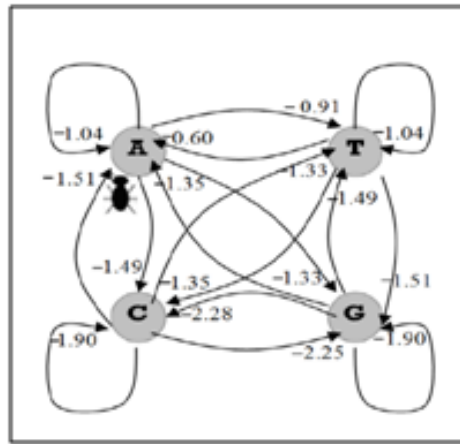

Figure 1: ACS modelling for DNA sequence design problem with thermodynamic value(Kurniawan et al., 2008)

Sequence	C	HA	HM	S
Ant Colony System				
GCGAAGATGGTCTATATCGG	0	0	102	71
ATCCTCTCTCCTAACGCAAG	0	0	82	86
CTCTCTCTCCTAATCCACA	0	0	69	91
GCATAACTCTCCGGACCTAT	0	0	85	80
GGCTTGCTATCGATCTGATG	0	0	95	78
TTCGACTTTGAATACGCGC	0	0	98	79
ACTACACCTCCTTATGCC	0	0	80	88

Figure 2: The obtained result from the previous approach (Kurniawan et al., 2008)

## 2 RESEARCH METHODOLOGY

### 2.1 DNA Sequence Design Problem

In DNA computing, hybridization between a DNA sequence and its base-pairing complement is the most important factor to retrieve the information stored in DNA sequences and operate the computation processes. For this reason, the desired set of good DNA sequences, which have a stable duplex with their complement are more needed. It is also important to ensure that two sequences are not complement to each other. Non-interacting sequences should be prohibitive or relatively unstable, compared with any perfectly matched duplex formed from a DNA sequence and its complement (Brenneman and Condon, 2002).

The objective of the DNA sequence optimization problem is basically to obtain a set of DNA sequences, where each sequence is unique or cannot be hybridized with other sequences in the set. In this paper, the objective functions and constraints from (Kurniawan et al., 2008) are used. Two objective functions, namely *hmeasure* and *similarity*, are chosen to estimate the uniqueness of each DNA sequence. Moreover, two additional objective functions, which are *hairpin* and *continuity*, are used in order to prevent secondary structure of a DNA sequence. Furthermore, two constraints, which are *GC content* and *melting temperature*, are used to keep uniform chemical characteristics.

DNA sequence optimization is actually a multi-objective optimization problem. However, the problem is converted into single-objective problem, which can be formulated as follows:

$$\min f_{DNA} = \sum_i w_i f_i \quad (1)$$

where  $f_i$  is the objective function for each  $i \in \{hmeasure, similarity, hairpin, continuity\}$  and  $w_i$  is the weight for each  $f_i$ . In this study, weights are set to one.

### 2.2 Ant Colony System

Ant colony optimization (ACO) is a population-based meta-heuristic for combinatorial optimization problems. The ACO was inspired by the ability of ants to find the shortest path between their nest and a source of food. Marco Dorigo introduced ACO in his PhD thesis (Dorigo, 1992) and applied it to the Traveling Salesman Problem (TSP). It has been applied to the quadratic assignment problem (Maniezzo et al., 1994), the vehicle routing problem (Bullnherimer et al., 1999), bin packing, stock cutting (Ducatellet and Levine, 2001) and RNA secondary structure prediction (McMella, 2006).

Ant Colony System (ACS) is an improved Ant System (AS) (Dorigo, 1992) in three main aspects: state transition rule, global updating rule, and local pheromone updating rule (Dorigo and Luca, 1997). The ACS algorithm for DNA Sequence Design Problem can be seen in (Kurniawan et al., 2008).

### 2.3 Hierarchical Updating Pheromone in Ant Colony System

Finite state machine as a model for constructing a DNA sequence was proposed by (Kurniawan et al., 2008) as shown in Figure 3. Since there are only four nodes in the state as represent a node in DNA, the tour will visit a node repeatedly. Furthermore, the pheromone in some path will become higher than others as shown in Figure 4. This will cause the tour tend to choose these path and the DNA sequence obtained from this tour will have pattern



Table 1: Comparison Results of Proposed Approach and result of previous work (Kurniawan et al., 2008)

Sequence	<i>continuity</i>	<i>hairpin</i>	<i>hmeasure</i>	<i>similarity</i>
[Previous work (Kurniawan et al., 2008)]				
GCGAAGATGGTCTATATCGG	0	0	102	71
ATCCTCTCTCCTAACGCAAG	0	0	82	86
CTCTCTCCTCCTAATCCACA	0	0	69	91
GCATAACTCTCCGGACCTAT	0	0	85	80
GGCTTGCTATCGATCTGATG	0	0	95	78
TTCGACTCTTGAATACGCGC	0	0	98	79
ACTACACCTCCTCTTATGCC	0	0	80	88
Total	0	0	611	573
Average	0	0	87.29	81.86
[Proposed approach / Hierarchical pheromone updating]				
ACTAGCGACCGGATGATTAC	0	0	80	64
TCTACTACTCTACTCCGGCA	0	0	80	66
CGTAGCACCTTGCATGATC	0	0	81	67
CGACGTACGAGTATGATCTC	0	0	82	64
GATGCGATAGAGATCTACGC	0	0	88	68
CCGACTGAATTGACGACTGA	0	0	83	66
GTGGAGAACAGGCTTATGAG	0	0	86	66
Total	0	0	580	461
Average	0	0	82.86	65.86

repeating in some DNA bases only as shown in Figure 2 and the DNA sequences will be difficult to satisfy the constraints *GC-content* and *Tm*.

In order to overcome these problems, a hierarchical pheromone updating technique is proposed as shown in Figure 5. Instead of having a single set of nodes of DNA for a single run, this model has a set of nodes of DNA for each level of construction process. For every level state transition in ACS mechanism, there is a set of DNA paths that can be chosen based on their own pheromone and not to choose nodes in the same level.

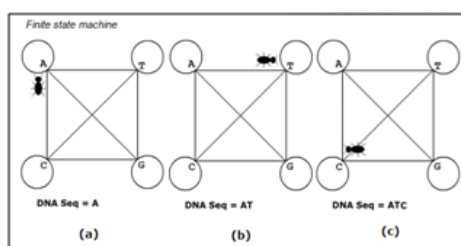

Figure 3: Finite state machine as a model for constructing a DNA Sequence (Kurniawan et al., 2008)

Figure 5 illustrates that in order to generate a 20mer of DNA sequence, there are 20 levels where each level has a set of nodes of DNAs. For each level, there are four nodes, where each node has four different paths that link to the other nodes in the next level. Each node in the same level is not connected by any paths for interconnection. Therefore, each node in the

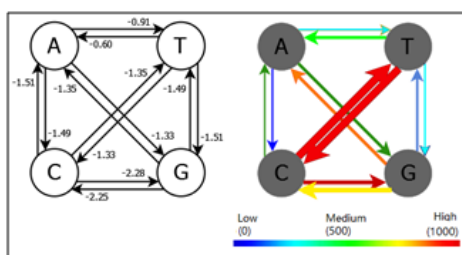

Figure 4: The paths of ACS model for DNA Sequence Problem and their pheromone for each path(Kurniawan et al., 2008)

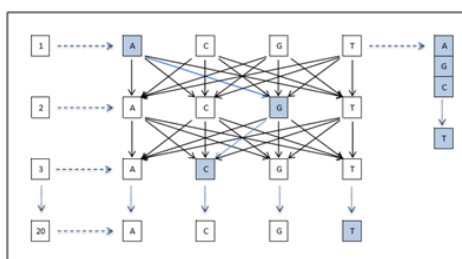

Figure 5: The Proposed Model, Hierarchical Updating Pheromone in ACS for DNA Sequence Design Problem

same level cannot be traversal to each other. This mechanism ensures that the pheromone will be updated with different path for each level of sequence.

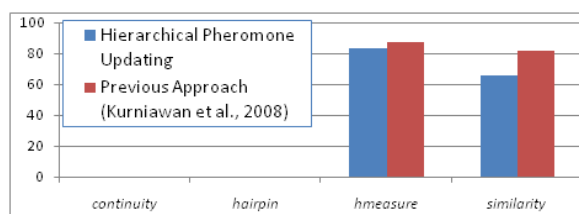

Figure 6: Average fitness comparison results between hierarchical pheromone updating and previous work (Kurniawan et al., 2008)

### 3 RESULTS AND DISCUSSION

The sequences obtained from the proposed approach are compared with the sequences generated by different methods. For comparison purposes, each of the compared methods runs 300 times and the results obtained are reported based on a same parameters reported in (Kurniawan et al., 2008).

The comparison results between our results obtained from proposed approach with result obtained from previous work (Kurniawan et al., 2008) are shown in Table 1 and Fig 6. Since

Table 2: Comparison Number of failed DNA Sequences

Approach	# Satisfy	# Not Satisfy	Total(300 x 7)
Hierarchical Pheromone Updating	1955(93.10%)	145 (6.90%)	2100
Pervious work (Kurniawan et al., 2008)	1034 (49.24%)	1066(50.76%)	2100

this optimization process is about finding the minimum values for the objective function, the smallest value will be the best result. On the other hand, since the multi-objective problem is converted into a single objective problem, the overall results reported in this paper are by the total objective values. Table 1 and Fig 6 show that the new proposed approach obtained a much lower total objective values than the previous work(Kurniawan et al., 2008). The new proposed method acquires lower similarity and hmeasure objective and the pattern shows that there are not repeating nodes in the solutions.

Further experiment has been conducted by collecting DNA sequences that were not able to satisfy the constraints. The collected sequences from two compared methods are shown in Table 2. The experiments runs for 300 iterations and for each iteration generates 7 sequences. Thus, 21,000 DNA sequences were generated for each method. Table 2 tabulates the results obtained from the experiments shows that the proposed method has smaller value (6.90%) for not satisfying the DNA Sequence constraints compared to previous works (50.76%). The results shows that the new method has better opportunity to get a better solutions.

## 4 CONCLUSION

A new method called Hierarchical Pheromone Updating Mechanism for ACS in Designing DNA is proposed and implemented with four objective functions: *hmeasure*, *similarity*, *continuity*, and *hairpin* and two constraints: *GC-content* and *melting temperature*. The DNA sequences obtained from the proposed method were compared with the results reported in (Kurniawan et al., 2008). The results show that new method can generate better DNA sequences where there are no repeated pattern of nodes and get more chance to satisfy the constraints in order to obtain better results in term of *hmeasure* and *similarity* objective.

## References

- Brenneman.A, Condon. A, (2002), Strand design for biomolecular computation, *Theory: Comput. Sci*, Vol. 287.
- Bullnheimer B., Hartl R.F., Strauss C., (1999), An improved Ant System algorithm for the Vehicle Routing Problem, *Annals of Operations Research*, Volume 89, Issue 0, 319–328.
- Deaton R., Chen J., Bi H., Garzon M., Rubin H., and Wood D.H., (2002), A PCR based protocol for in vitro selection of noncross hybridizing oligonucleotides, *Proceedings of the 8th International Workshop DNA Based Computers*, pp. 196-204.
- Dorigo M., (1992), Optimization, learning and natural algorithms, *PhD Thesis*, Dipartimento di Elettronica, Politecnico di Milano, Italy.
- Dorigo M., Luca. M.G, (1997), Ant Colony System: A cooperative learning approach to the Traveling Salesman Problem, *IEEE Trans. Evol. Comput*, vol. 1.

- Ducatelle F. and Levine J., (2001), Ant Colony Optimisation for Bin Packing and Cutting Stock Problems, *presented at UK Workshop on Computational Intelligence (UKCI-01)*, Edinburgh.
- Feldkamp U., Saghafi S., Banzhaf W., and Rauhe H., (2001), DNA sequence generator - A program for the construction of DNA sequences, *Proceedings of the 7th International Workshop DNA Based Computers*, pp. 179188.
- Frutos A.G., Thiel A.J., Condon A.E., Smith L.M., and Corn R.M., (1997), DNA computing at surfaces: Four base mismatch word design, *Proceedings of the 3rd DIMACS Workshop DNA Based Computers*, pp. 238.
- Hartemink A.J., Gifford D.K., and Khodor J., (1998), Automated constraint based nucleotide sequence selection for DNA computation, *Proceedings of the 4th DIMACS Workshop DNA Based Computers*, pp. 227-235 36.
- Kurniawan, T.B., Khalid, N.K., Ibrahim, Z., Khalid, M., Middendorf, M., (2008), An Ant Colony System for DNA Sequence Design Based On Thermodynamics. In: *Proceedings of the Fourth IASTED International Conference Advances in Computer Science and Technology (ACST 2008)*, Langkawi, Malaysia, pp. 144149.
- Maniezzo V., Colorni A., and Dorigo M., (1994), The ant system applied to the quadratic assignment problem, *Universite Libre de Bruxelles, Belgium, Tech. Rep. IRIDIA/94-28*.
- Marathe A., Condon A.E., and Corn R.M., (1999), On combinatorial DNA word design, *Proceedings of the 5th DIMACS Workshop DNA Based Computers*, pp. 7589.
- McMellan, N., (2006), RNA Secondary Structure Prediction using Ant Colony Optimisation, *Master Thesis*, School of Informatics, University of Edinburgh.
- Penchovsky R. and Ackermann J., (2003), DNA library design for molecular computation, *Journal of Computational Biology*, Vol. 10, No. 2, pp. 215229.
- Shin S.Y., Lee I.H., Kim B, Zhang B.T. (2005), Multiobjective evolutionary optimization of DNA sequences for reliable DNA computing, *IEEE Transaction on Evolutionary Computation*, Vol. 9, No. 2.
- Tanaka F., Nakatsugawa M., Yamamoto M., Shiba T., and Ohuchi A., (2001), Developing support system for sequence design in DNA computing, *Proceedings of the 7th International Workshop DNA Based Computers*, pp. 340349.
- Zhang B.T. and Shin S.Y., (1998), Molecular algorithms for efficient and reliable DNA computing, *Proceedings of Genetic Programming*, pp. 735742.

## Maximize E-Learning To Improve Students Knowledge and Interest In Learning

**Burham Isnanto, Bambang Adiwino, Ellya Helmud**

STMIK Atma Luhur, Bangka Belitung  
e-mail: Burham@atmaluhur.ac.id, baw@atmaluhur.ac.id,  
ellyahelmud@atmaluhur.ac.id

### ***Abstract***

*E-learning has been believed to be an effective method to increase the knowledge of students and increase student interest in learning. The success of an e-learning is strongly influenced by the user that is lecture and students and the media used. This study aims to create an e-learning prototype, evaluate its implementation and perform prototypes quality testing made to know what factors that should be considered to maximize the functionality of e-learning. The method used is the technique of data collection using questionnaires, design techniques using methods of object-oriented analysis and design: unified modeling language (UML), testing the quality of the e-learning prototype was tested by four characteristics ISO 9126 testing models, namely: functionality, reliability, usability, and efficiency. The result achieved is a prototype of e-learning that is attractive to students, easily updated by the lecturer, is easy to use by students and meet the quality standards of ISO 9126 with good results.*

**Keywords :** *e-learning, iso 9126, UML, prototipe*

### **1 INTRODUCTION**

Nowadays, information technology has become the solution to every problem mankind faces included in the learning process. The existence of e-learning methods facilitate the learning process so that everyone can learn anywhere anytime. The medium used for e-learning can be any combination of text, graphics, audio, video, and animation. The fact that e-learning system can help education institution in reaching more student is undeniable. This system can help lectures communicate, share, and discuss matters with their students.

The combination of e-learning media are a combination of images, illustrations, charts, audio, and visual elements that are part of multimedia learning objects (Salman, 2012). Online learning performance of several universities in Jakarta are still not maximized its use (William, 2012). The the lack of e-learning implementation are due several factors that are not easy to use, look unattractive, share data is not running good, the data is not updated, the lack of experience of lecturers, and slow internet access (Diana, 2012). Institution need to support

the implementation of e-learning (Abdillah, 2013). Learning using social media that produces some of the factors that affect learning in the public media learning is context element, content element, public customization elements, connection elements, elements of communication, and community elements (Fenny, 2013). E-learning enable knowledge maangement in education institution (Abdillah, 2014).

This study aims to create ane-learning prototype , evaluate its implementation and perform prototypes quality testing made to known what factors that should be considered to maximize the functionality of e-learning.

## **2 RESEARCH METHODOLOGY**

### **2.1 Sample Selection Methods**

Sampling selection using purposive sampling technique by taking selected respondents completely by the researcher according to specific characteristics possessed by the sample. (Nasution, 2009)

### **2.2 Data Collecting Method**

1. Observation method, or by conducting field visits and direct observation of the object of research.
2. Interview method, which is done by involving the parties involved in the research to take the data evaluation and testing ISO 9126.
3. Study library method.

### **2.3 System Design Technique**

Program design or specifications of the system, which includes:

1. Making Use Case
2. Making Activity Diagrams.
3. Making WSDL diagram.
4. Making Class Diagram.
5. Making Deployment Diagram.
6. Database Design.
7. System architecture design (hardware, software, networks).

### **2.4 Testing Model ISO 9126**

Validity of the construct testing is done by calculating the correlation between each statement with a total score. In testing the validity of the instrument of this study, using Pearson Product Moment correlation with software tools IBM SPSS Statistics 21. Reliability testing used in the study is the alpha cronbach method.

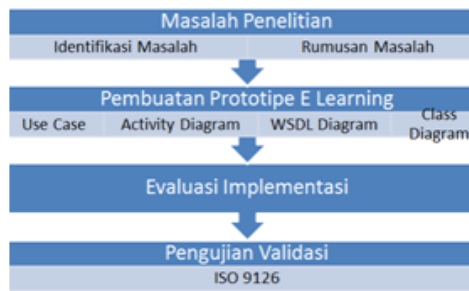

Figure 1: Research Step

## 2.5 Research Step

## 3 DISCUSSIONS

### 3.1 E-Learning

e-learning is a type of learning that allows conveyed teaching materials for students by using the internet, intranet, or other computer network media (Darin, 2001). Furthermore, It is an education system that uses an electronic application to support the teaching and learning with the Internet and network media (Jenkinson, 2009).



Figure 2: E Learning (Anderson, 2004)

Online learning allows flexibility of access from anywhere without geographical and time barrier (Anderson, 2004). However the material must be designed properly to enhance the learning effectiveness. Using media such as audio, visual or both are technologies that help students gain significant learning benefit.

Benefits of e-learning (Alsultany, 2006), among others:

1. The information obtained is consistent and can be changed as needed

2. Its contents can be updated appropriately and accurately and quickly distributed to users.
3. This method allows users to perform learning anytime anywhere.
4. E learning is universality which means that e-learning can make any users who use it to get the same learning content at the same time
5. E-learning is scalability because it can be developed with little effort and expense

### 3.2 Testing Model ISO 9126

External quality characteristics are the parts of a product related to the wearer (Simarmata, 2010), while the internal quality characteristics are not directly related to the user. ISO 9126 standard in figure 3 (Al-Qutaish, 2010) has been developed in an attempt to identify the key attributes of quality for computer software. According to ISO 9126 quality factor includes six quality characteristics as follows:

1. Functionality. The ability of the software to provide functions according to user needs
2. Reliability. Software's ability to maintain a certain level of performance
3. Usability. The ability of the software to be understood, learned, used, and attractive to users
4. Efficiency. The ability of the software to provide appropriate performance and relative to the number of sources
5. Maintainability. The ability of the software to be modified.
6. Portability. The ability of the software to be transferred from one environment to another environment.

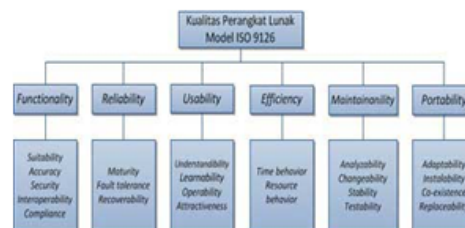

Figure 3: ISO 9126 Models

### 3.3 Interface Construction

The success of an e-learning methods can be known from the ease of lecturers provide the material and the level of student understanding. Students habits in using computer and students habits in online also affect the success of e-learning.





Figure 4: E-Learning User Interface

In addition there is a menu to support the implementation of e-learning between lecturers and students also are campus agenda as student activities of each SME, the latest announcements from the campus, and there are polling input from students on an academic issue.



Figure 5: Lecturers Control Panel

This form is used by the admin in BAAK or BSI and lecturers to upload material that will be needed by students to gain knowledge such as: lectures, coursework, SAP courses, exam results, tips and tricks ebook, ebook databases, multimedia ebook, programming ebook, and linux ebook.

### 3.4 System Testing

Respondents in the implementation of quality tests are a few lecturers and students of the total respondents as many as 200 people. Respondents were categorized by sex, education last, computer time usage, interest and use of the Internet.

Results for discussion of media is: media video and animation is very interesting, this media can add student understanding and can increase student interest in learning because it is easier for students to get knowledge that delivered by lecturers. Students do not need to interpret its own purpose. Media images in the form of twodimensional images or illustrations are also attractive and increase student comprehension but not all of the intent of the lecturers could be delivered because the data held by the student is not much that require active participation from students. Audio media into the media was not selected because it tends to

Table 1: ISO 9126 Calculation Result

Aspek	Actual Score	Ideal Score	% Actual Score	Criteria
<i>Functionality</i>	1563	2000	78,15%	Baik
<i>Reliability</i>	996	1250	79,68%	Baik
<i>Usability</i>	1604	2000	80,20%	Baik
<i>Efficiency</i>	588	750	78,40%	Baik
<b>Total</b>	<b>4751</b>	<b>6000</b>	<b>79,18%</b>	<b>Baik</b>

make students become bored, understanding gained from the audio is not great because it is from the beginning has not attractive. The existence of links to scientific reference material on the subject of discussion is felt greatly assist students in learning a subject for students to be more focused and could look for more examples.

For user that already get used to work using computer affect the student activity in finding the information contained in e-learning. Students who are already accustomed to using computers will not be difficult to find a source of learning from professors. In terms of internet usage shows that the browsing and the use of social media so dominant that it is necessary to combine e-learning with social media as a medium of learning.

### 3.5 ISO 9126 Models

Validity of test results of 200 respondents using Pearson Product Moment Correlation table values obtained correlation between the scores of the items with the total score for the four variables: functionality, reliability, usability, and efficiency is greater than 0,138 so that it can be valid. Rtable value of 0.138 for  $n = 200$  (Based on R table) (Sugiyono, 2010). Reliability tests performed with Cronbach alpha ( $\alpha$ ). Instruments used in the variable is said to reliable (reliable) if it has more than a Cronbach alpha of 0.60 (Sekaran, 2006). The test results of 4 variables produce iso 9126:

1. For functionality AC value = 0.634
2. For reliability AC value = 0.714
3. For usability AC value = 0.682
4. For efficiency AC value = 0.768

From these results we concluded that for the four variables can be said to be reliable.

ISO 9126 calculation results showed that the level of quality learning software e-learning model in the Good criteria overall, with a percentage of 79.18%. Aspects of the highest quality is based on Usability aspects with a percentage of 80.20%, which indicates that the prototype e-learning produced is easy to understand, easy to learn, easy to use, and attractive in users appearance. Following aspects with 79.68% is Reliability indicates the level of performance can be categorized either. Efficiency aspects with a percentage of 78.40% indicates that the prototype is no problem even if used simultaneously and the performance is relatively stable, while the lowest is the quality aspect of the aspects of functionality with a percentage of 78.15% which indicates the prototype could provide functions according to user needs.

### 3.6 Acunetix WVS 8 Software Testing

Acunetix is a software that is used by network security pentester web, this software is used to find the weak points of a web-based application that can subsequently be covered with repair existing weak points. Acunetix commonly used by IT consultants or Web Developer in testing web applications.

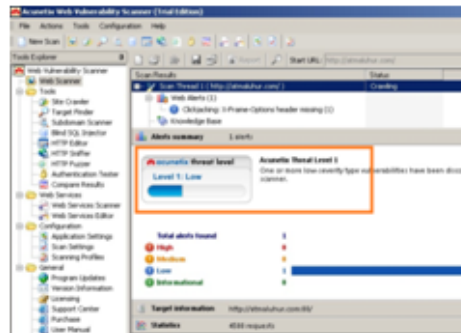

Figure 6: Average fitness comparison results between hierarchical pheromone updating and previous work (Kurniawan et al., 2008)

From the test results shows that the level of thread-level there is at level 1 (low) after the 4588 request. Threats only form of information, ie the existence of the X-Frame option header is missing in my PHP Admin her. This indicates that there are no loopholes in PHP prototype e-learning made.

## 4 CONCLUSIONS

From the discussion we concluded as follows:

1. Factors affecting the success of e-learning can come from:
  - (a) User habits: habits using a computer, and online time usage
  - (b) Media used: audio, picture, video, animation
  - (c) Application of e-learning made.
2. Results of the evaluation of e-learning on campus XYZ is easily updated by the lecturer, and easy to use by students.
3. The results of using the ISO 9126 quality testing and software are:
  - (a) ISO 9126 calculation results showed that the level of quality learning software e-learning model in the Good criteria overall, with the percentage of 79.18%. usability aspects with a percentage of 80.20%, reliability aspects with 79.68% , efficiency aspects with percentage of 78.40%, and functionality aspects with a percentage of 78.15%.
  - (b) From the results of software testing Acunetic WVS 8 indicates that there are no loopholes in PHP prototype e- learning made

## References

- Abdillah, L. A. (2013). Students learning center strategy based on e-learning and blogs, *in Seminar Nasional Sains dan Teknologi (SNST) ke-4 Tahun 2013*, Fakultas Teknik Universitas Wahid Hasyim Semarang 2013, pp. F.3.15-20.
- Abdillah, L. A. (2014). Managing information and knowledge sharing cultures in higher education institutions, *in The 11th International Research Conference on Quality, Innovation, and Knowledge Management (QIK2014)*, The Trans Luxury Hotel, Bandung, Indonesia, 2014.
- Alsultany. (2006). E-Learning System Overview Based On Semantic Web. *Electronic Journal Of E-Learning*, 4
- Al-Qutaish (2010), Rafa, E. Quality Models in Software Engineering Literature: An Analytical and Comparative Study. *Journal of American Science*, vol. 6 : 166-175.
- Anderson. (2004). *Theory and Practice Of Online Learning*. Canada: Athabasca University.
- Darin, H (2001). Selling E-Learning. *American Society For Training And Development*.
- Diana. (2012). *Evaluasi Penggunaan E-Learning Dari Sisi Dosen Dan Mahasiswa*. Jakarta: Universitas Bina Nusantara
- Fenny. (2013). *Perancangan Model Pembelajaran Menggunakan Media Sosial*. Jakarta: Universitas Bina Nusantara.
- Jenkinson, J (2009). Measuring The Effectiveness of Educational Technology. *Electronic Journal Of E-Learning* Volume 7 Issue 3, 273.
- Nasution. (2009). *Metode Research*. Jakarta: PT Bumi Aksara.
- Salman. (2012). *Analisis Faktor-Faktor Komponen Multimedia Sebagai Learning Object Dalam Bidang Edukasi*. Jakarta: Universitas Bina Nusantara
- Sekaran, Uma. (2006). *Research Methods For Business: Metodologi Penelitian Untuk Bisnis*, Buku 2. Salemb Empat: Jakarta
- Simarmata (2010). Janner. *Rekayasa Perangkat Lunak*. Yogyakarta: ANDI
- Sugiyono (2012). *Metode Penelitian Kuantitatif, Kualitatif, dan R&D*. Bandung: Alfabeta.
- William. (2012). *The Performance Expectation Of Online Learning System In Jakarta Undergraduate Universities*. Jakarta: Universitas Bina Nusantara.

## Information System of Follow Up Evaluation Report Multi User Based On The Bangka Belitung Inspectorate Department

**Ellya Helmud, Burham Isnanto, Sujono**

STMIK Atma Luhur, Bangka Belitung  
e-mail: ellyahelmud@atmaluhur.ac.id, burham@atmaluhur.ac.id,  
Sujono@atmaluhur.ac.id

### ***Abstract***

*Work performance improvement and human resources professionalism can not be separated from the infrastructure that either one of them is to have Information and Communication Technology and content in accordance with the requirements therein. Good decisions can not be separated from ICT as supporters. Where the data is processed and processed to produce an information. Follow-up information systems Evaluation Report of Examination Results-Based Multiuser is one of the content is designed and created using object-oriented methodologies with software tools UML (Unified Modeling Language), direct observation, and interviews with relevant parties. The purpose of this research is to obtain the actual data so that we can found weaknesses in the old system, then improved by using the new system. Inspectorate Department of Bangka Belitung have many targets to be met which leads to the desired conditions that minimize the use of funds even remove deviant who cause loss to the state. Research result is an application that can provide the best solution to resolve the processes associated with the results of the evaluation report on the Office of the Provincial Inspectorate of Bangka Belitung.*

**Keywords :** *Evaluation, Information, WEB, multi-user, inspectorate*

### **1 INTRODUCTION**

Bangka Belitung Inspectorate is a government agency which has an important role as a government internal control apparatus. In accordance with its vision: "Leadership in guarding Bangka Belitung province Government through increased professionalism surveillance apparatus to create Good Governance and Clean Government". Therefore, the application of information systems is necessary for data accessibility is presented in a timely and accurate for users, especially data that will be presented is very large and requires a lot of computation, especially the financial audit process with respect to the examination findings department official results concerning the use of budget funds government annually. System information such as program-multi-user based application with various reports generated are expected to

triggers all stakeholder needs so that the vision of the provincial inspectorate Bangka Belitung can be realized and moral responsibility as a government internal control apparatus can be implemented properly.

## **2 RESEARCH METHODOLOGY**

### **2.1 Observation Method**

SBy direct observation and conduct a review of the activities in the library to find the data that is in need, so it can be seen that the business process is running.

### **2.2 Interview Method**

Conducting interviews with related parties to obtain study materials that may be separated from the observations.

### **2.3 Study Library Method**

Authors also search for data and information from the library by studying books or the dictates relating to the preparation of this study.

## **3 DISCUSSIONS**

### **3.1 Object Oriented Analysis Design**

According to Adi Nugroho (Adi, 2005) system analysis can be expressed as the separation of a case in certain parts. The sections were then studied and evacuated to determine whether there are ways to better meet the needs of management. According Sutopo system analysis is the process of determining the needs of the system - what should be done to meet the needs of the client system, not how the system is implemented (Sutopo, 2002: 242). The basic concepts of object-oriented reach maturity at the time of the analysis and design problems become more noticed than the coding problem. Specifically, the term "object-oriented" (Sutopo, 2002: 3) means that "we organize the software as a collection of specific objects that have data structure and behavior".

### **3.2 Unified Modelling Language (UML)**

According to Martin (Martin, 2005) Unified Modeling Language (UML) is a "language" which has become the industry standard for visualizing, designing and documenting software systems. UML offers a standard for designing a model of a system. By using UML we can create a model for all types of software applications, where the application can run on any hardware, operating system and network sharing, and written in any programming language. Also because UML use the class and operation in the basic concept, then it is more suitable for writing software in object-oriented languages (Irwanto, 2006). UML notation is mainly derived from the 3 existing notation: Grady Booch OOD (Object-Oriented Design), Jim Rumbaugh OMT (Object Modeling Technique), and Ivar Jacobson OOSE (Object-Oriented Software Engineering).

### 3.3 Computers Network

Computer Network is a collection of computers and other equipment are connected in one unit (Budhi, 2005). Information and data moving through wires or wirelessly allowing the network users can exchange documents and data, print on the same printer and together using hardware and software that is connected in a network. Each computer, printer, or peripherals that are connected in a network are called nodes of a computer network can have two, tens, thousands, even millions of nodes (Budhi, 2005). Designed star topology where each nodes (file servers, workstations and other devices) connected to the network through a concentrator (hub or switch). This topology is used for LAN, MAN, or WAN.



Figure 1: Network Topology

### 3.4 Black Box Testing Models

Black box methods focuses on requirements or functional requirements of software are made. Black box testing methods focus on the functional needs of the software. Therefore, Black Box testing method makes it possible to create a set of input conditions that will train all the functional requirements of a program (Rex, 2002).

### 3.5 Analysis of Needs

Analysis method used in the development of this research is using object-oriented analysis with UML as modeling tools. From the analysis of the existing problems were identified object any role in the system and to be developed further and more detailed in the results of the analysis.



Figure 2: Package Diagram

Based on the analysis of existing ones, then the specified grade class involved in the system and attributes attributes of each class are described in a class diagram.

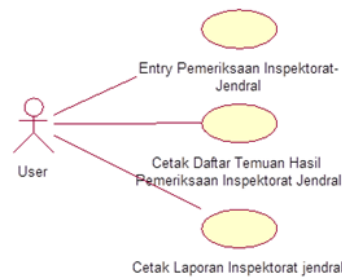

Figure 3: Uses Case Screening Packages Inspectorate

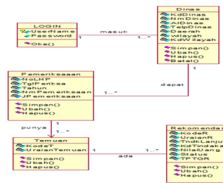

Figure 4: Class diagram for the actors and entities involved in the system

### 3.6 Software used

1. Rational Rose 2000 as a tool in the manufacture of UML modeling for process analysis and design.
2. Design Interface. In designing Form and programming language used is Microsoft Visual Basic 6.0.
3. Operating System and Database. Server with Windows Server operating system 2003, the database server by using the Oracle 10.g for data storage.

### 3.7 Display Some Important Form



Figure 5: a)Main Menu b)Form Login





Figure 6: a)Form Office Data Collection, b)Form Inspectorate Examination Entry

Collection Agency need to perform data input to all services in the Bangka Belitung  
This form is used to enter all the checks and the findings of the agency that will be in  
check.

### 3.8 System Testing

System testing by discussion was attended by the respondents representing the inspectorate concerned. Researchers do presentations and demos showing the new website that has been created and the applications made and explains every function that is based on the instrument that had been prepared. Having watched and knew how to operate the application, then respondents were given the opportunity to try to direct use. Furthermore, participants providing information, feedback and approval form that has been provided by the researcher before the respondent tried on each computer. Based on tests conducted by the respondent, it will obtain the test results of the functional system based on the needs of each user is an administrator, and staff.

Based on the results of black box testing performed by the competent persons and the inspectorate chairman, it can be concluded that the information system made are in accordance with the specification of functional requirements required of the user. Therefore, based on the analysis, design and construction of software for information system can function properly and produce a good validation

## 4 CONCLUSIONS

From the discussion we concluded as follows:

1. Information systems of follow-up evaluation reports multiuser based on the Bangka Belitung inspectorate department made will make it easier for inspectorate staff to knowing information about the examination and evaluation.
2. Facilitate the search data quickly to the results of the examination conducted by the inspectorate staff in previous years and the data can be well-documented in the electronic data storage media.

Table 1: black box test result

Data Masuk	Yang diharapkan	Pengamatan	Kesimpulan Pengujian
Username :	Muncul	Konfirmasi Login	Sesuai
Password :	pesan Login	Sukses muncul dan	
Klik tombol	Sukses dan	Halaman Utama	
Login	membuka tampilan utamanya.	langsung terbuka.	
Username : User	Muncul	Muncul	Sesuai
Password : User	Konfirmasi Gagal	Konfirmasi Gagal	
Klik tombol	Login	Login	
Login			
Masukkan	Muncul	Muncul	Sesuai
Username dan	Konfirmasi Gagal	Konfirmasi Gagal	
Password yang	Login Anda	Login Anda	
salah berulangulng	Bukan Operator	Bukan Operator	
sebanyak	Yang Berhak	Yang Berhak.	
tiga kali.		Dan program	
Klik tombol		aplikasi langsung	
Login		ditutup	

3. Based on the results of black box testing is done, application made are in accordance with the specification of functional requirements required of the user. Therefore, based on the analysis, design and construction of software work properly.

## References

- Adi. (2005). *Analisis dan Perancangan Sistem Informasi Dengan Metodologi Berorientasi Objek*. Bandung: Informatika
- Andreas. (2006). *Panduan Pemrograman dan referensi kamus Visual Basic 6.0*. Jakarta.
- Black, Rex. (2002). *Managing The Testing Process*. 2st Ed., Microsoft Press, Redmond, Washington 98052-6399.
- Budhi, Irawan. (2005). *Jaringan Komputer*. Yogyakarta:Andi
- Irwanto, Djon. (2006). *Perancangan Object Oriented Software dengan UML*. Yogyakarta:Andi
- Sopandi, Dede. (2008). *Instalasi dan Konfigurasi Jaringan Komputer*. Bandung: Informatika
- Sutopo, Hadi, Ariesto. (2002). *Analisis dan Desain Berorientasi Objek*, Yogyakarta, J&J Learning
- Martin, Fowler. (2005). *UML Distilled Edisi 3, Panduan Singkat Tentang Bahasa Pemodelan Objek Standar*. Yogyakarta: Andi
- Nugroho, Adi (2008). *Menjadi Administrator Basis Data Oracle 10g*. Bandung: Informatika
- Whitten, Jeffrey L., Lonnie D. Bently, Kevin C.Dittman. (2004). *System Analysis and Design Methods*. 6 th ed. New York : Mc Graw-Hill

## Extracting Keyword for Disambiguating Name Base on The Overlap Principle

**Mahyuddin K. M. Nasution**

Universitas Sumatera Utara  
e-mail: mahyuddin@usu.ac.id

### *Abstract*

*Name disambiguation has become one of the main themes in the Semantic Web agenda. The semantic web is an extension of the current Web in which information is not only given well-defined meaning, but also has many purposes that contain the ambiguous naturally or a lot of thing came with the overlap, mainly deals with the persons name. Therefore, we develop an approach to extract keywords from web snippet with utilizing the overlap principle, a concept to understand things with ambiguous, whereby features of person are generated for dealing with the variety of web, the web is steadily gaining ground in the semantic research.*

**Keywords :** *semantic, synonymy, polysemy, snippet*

### 1 INTRODUCTION

In semantic the disambiguation is the process of identifying related to essence of word, the nature of which is passed on to any object or entity, and also the meaning is embedded to it by how people use it. Basically, the meaning has been stored in the dictionary, the dictionary was based on events that have occurred in the social, and today they have been shared on the web page. The issues of disambiguation therefore is related to the special case of WSD (word sense disambiguation) (Schutze, 1998; McCarthy et al., 2004), especially with the name of someone who is also the words.

Today, along with the growth of the web on the Internet, it is difficult to determine a web page associated with the intended person is right and proper, especially with the presence of semantic meaning as a synonymy and polysemy. Therefore, this paper expressed an approach for identifying a person with exploring web snippets.

Our study uses natural language processing, that is named entity recognition and extraction of keyword from summaries of documents with any name. The aim is to develop a method for extracting keyword from Web. For this purpose, the related work as conceptual bridge from what is already known, a model for cognitive structures in guide data gathering, and a approach for getting outlines for presenting interpretation to others, i.e. from dataset to experiment.

## 2 RESEARCH METHODOLOGY

### 2.1 Related Work

Most of works addressed the name disambiguation, among them about preparing information for person-specific (Mann and Yarowsky, 2003); finding to the association of persons such as the social networks (Bekkerman and McCallum, 2005); distinguishing the different persons with keyword/key phrases (Li et al., 2005), associating a domain of citations in the scientific papers (Han et al., 2005), etc. However, none of the mentioned works attempt to extract dynamic features of person as the current context to do name disambiguation through queries expansion as a way for fighting against explosion of information on the Internet, that is increasing and expanding relationship between the persons and the words continuously, mainly to face the common words like "information", that is an indwell word always for each person in information era. Semantically, there are motivations of disambiguation problem (Nasution and Noah, 2012) : (1) Meronymy (Nguyen and Cao, 2008a):  $x$  is part  $y$  or "is-a", part to whole relation - the semantic relation that holds between a part and the whole. In other word, the page for  $x$  belong to the categories of  $y$ . For example, the page for the Barack Obama in Wikipedia belong to the categories (a) President of the United State, (b) United States Senate, (c) Illinois Senate, (d) Black people, etc. In other case, some entities are associated with multi-categories. For example, Noam Chomsky is a linguist and Noam Chomsky is also a critic of American foreign policy. (2) Holonymy:  $x$  has  $y$  as part of itself or "has-a", whole to part relation - the semantic relation that holds between a whole and its parts. For example, in DBLP, the author name "Shahrul Azman Mohd Noah" has a name label as "Shahrul Azman Noah". (3) Hyponymy (Nguyen and Cao, 2008b):  $x$  be subordinate of  $y$  or "has-property", subordination - the semantic relation of being subordinate or belong to a lower rank or class. In other word, the page for  $x$  has subcategories of  $y$ . For example, the homepage of "Tengku Mohd Tengku Sembok" has categories pages: Home, Biography, Curriculum Vitae, Gallery, Others, Contact, Links, etc. Some pages also contain name label "Tengku Mohd Tengku Sembok". (4) Synonymy (Lloyd et al., 2005; Song et al., 2007):  $x$  denotes the same as  $y$ , the semantic relation that holds between two words or can (in the context) express the same meaning. This means that the entity may have multiple name variations/abbreviations in citations across publications. For example, in DBLP, the author name "Tengku Mohd Tengku Sembok" is sometimes written as "T. Mohd T. Sembok", "Tengku M. T. Sembok". (5) Polysemy (Song et al., 2007): Lexical ambiguity, individual word or phrase or label that can be used to express two or more different meanings. This means that different entities may share the same name label in multiple citations. For example, both "Guangyu Chen" and "Guilin Chen" are used as "G. Chen" in their citations.

### 2.2 A Model

Let  $A = \{ai|i = 1, , M\}$  is a set of person (real-world entities). There is  $Ad = \{bj|j = 1, , N\}$  as a set of ambiguous names which need to be disambiguated, e.g., {"JohnBarnes"}, thus  $A$  is a reference entities table containing peoples which the names in  $Ad$  may represent, e.g. {"John Barnes (computer scientist)", "John Barnes (American author)", "John Barnes (football player)", }.

Consider  $D = \{dk|k = 1, , K\}$  is a set of documents containing the names in  $Ad$ , where possibility  $At = \{atl|l = 1, , L\}$  is a set of composition of name tokens (first/middle/last name

or in abbreviations), and due to a person has multiple name variations, e.g., "Shahrul Azman Noah (Professor)" has names/aliases as in {"Shahrul Azman Mohd Noah", "Shahrul Azman Noah", "S. A. M. Noah", "Noah, S. A. M.", }. Moreover, the person's name sometimes affected by the background of social communities, like nation, tribes, religion, etc., where a community simply is characterized by the properties in common. For example, some names of Malaysia or Indonesia peoples sometimes insert special terms: "bin", "b", "binti" or "bt" (respect to "son of" or daughter of"), e.g., one name variation of "Shahrul Azman Noah" is "Shahrul Azman b Mohd Noah". In another case, an certain community give the characteristic to community's members, such as the academic community will add the academic degree such as "Prof." (professor) to its members.

Identifying named entity relates to all observed names in  $D$ , i.e.,  $Ax = \{axo|o = 1, , O\}$ , which need to be patterned and disambiguated. The person's names can be rendered differently in online information sources. They are not named with single pattern of tokens, they are not also labeled with unique identifiers, and therefore the names of people also associated with the uncertain things. Text searching relies on matching pattern, searching on a name based on pattern will only match the form a searcher enters in a search box. This causes low recall and negatively affects search precision (Branting, 2002), when the name of a single person is represented in different ways in the same database (Bhattachrya and Getoor, 2006), such as on the motivation above.

Indeed, in scientific publications such as from IEEE, ACM, Springer, etc., all need the shortened forms of name, especially forenames represented only by initials. However, the shortened form of name is not only makes the name variation, but it creates the name ambiguity in online information sources, such as Web. For example, the name "J. Barnes" can represent "John Barnes (computer scientist)", "Jack Barnes (American communist leader)", "Johnnie Barnes (American football player)", "Johnny Barnes (Bermudian eccentric)", "Joshua Barnes (English scholar)", etc. Name disambiguation is an important problem in information extraction about persons, and is one of themes in Semantic Web. Thus, the persons name can be expressed by using different aliases due to multiple reasons as motives: use of abbreviations, different naming conventions, misspelling, pseudonyms in publication or bibliographies (citations), or naming variations over time. Some different real world entities have the same name, or they share some aliases. So, it is also a semantic problem. We conclude that there are two fundamental reasons of name disambiguation semantically for identifying entities generally, or persons specially, i.e., (a) different entities can share the same name (lexical ambiguity), and (b) a single entity can be designated by multiple names (referential ambiguity). Formally, these name disambiguation problems have tasks: (a) for all  $a$  in  $A$ , there is a relation  $\xi$  to assign a list of documents  $D$  containing  $a$  such that  $\xi(M : N)A \rightarrow Ad$ ,  $Ad$  is a subset of  $Ax$ , where  $\xi(a)$  in  $Ad$ , (b) for all  $a$  in  $A$ , there is a relation  $\zeta(M : L)A \rightarrow At$ ,  $At$  is a subset of  $Ax$ , where  $\zeta(a)$  in  $At$ . Semantically, extracting the keyword from web snippet is to tie  $\xi$  and  $\zeta$  into a bundle whereby a group of documents exactly associate with one entity only (Nasution and Noah, 2012).

### 2.3 Proposed Approach

We start this approach with describing some concepts: (1) A word  $w$  is the basic unit of discrete data, defined to be an item from a vocabulary indexed by  $\{1, \dots, K\}$ , where  $w_k = 1$  if  $k$  in  $K$ , and  $w_k = 0$  otherwise; (2) A term  $tx$  consists of at least one word or a sequence

Table 1: Statistics of our dataset

Personal Name	Position	Number of pages
Abdul Razak Hamdan	Professor	85
Abdullah Mohd Zin	Professor	90
Shahrul Azman Mohd Noah	Professor	134
Tengku Mohd Tengku Sembok	Professor	189
Md Jan Nordin	Professor	41

of words, or  $tx = (w_1, \dots, w_l)$ ,  $l = k$ ,  $k$  is a number of parameters representing word, and  $|tx| = k$  is size of  $tx$ ; (3) Let a web page denoted by  $\omega$  and a set of web pages indexed by search engine be  $\Omega$  containing pairs of term and web page. Let  $tx$  is a search term and a web page contain  $tx$  is  $\omega_{tx}$ , we obtain  $\Omega_{tx} = \{(tx, \omega_{tx})\}$ ,  $\Omega_{tx}$  is a subset of  $\Omega$ , or  $tx$  in  $\omega_{tx}$  in  $\Omega_{tx}$ .  $|\Omega_{tx}| = |\{(tx, \omega_{tx})\}|$  is cardinality of  $\Omega_{tx}$ ; (4) Let  $tx$  is a search term.  $S = \{s_1, \dots, s_{max}\}$  is a web snippet (briefly snippet) about  $tx$  that returned by search engine, where  $max = \pm 50$  words.  $L = \{S_i | i = 1, \dots, N\}$  is a list of snippet.

Based on these concepts, we develop an approach based on the overlap principle (Nasution, 2010a) to extract keywords from web snippet. The interpretation of overlap principle by using the query as a composition of  $tx \cap ty$  or " $tx, ty$ " is to get a reflection the real world from the web, while to implement it we use one of similarity measures, for example, the similarity based on Kolmogorov complexity (Nasution, 2010b)

$$Sim(t_x, t_y) = \log(2|\Omega_{t_x} \cap \Omega_{t_y}| / (\log(|\Omega_{t_x}| + |\Omega_{t_y}|))) \quad (1)$$

We assume that all the ambiguity is caused by overlapping interpretations and understanding of the things that exist in the real world. This assumption describes the usefulness of intersection of regular sets. Therefore, we can formulate the conditions of the overlap principle as follows. For first condition (Condition 1): Let  $t_x$  be a term and  $t_a$  is a representation term of person name  $a$  in  $A$ . We define a condition of overlap principle of  $t_x$  and  $t_a$ , i.e.,  $t_a \cup t_x = \emptyset$ , but  $t_a, t_x$  in  $\omega_{t_a}$  and  $t_a, t_x$  in  $\omega_{t_x}$ , such that  $t_a, t_x$  in  $S$ . Second condition (Condition 2): Let  $t_a, t_x, t_y$  in  $S$  with  $|\Omega_{t_x}| = |\Omega_{t_y}|$ . We define a condition of overlap principle between  $t_a$  and  $t_x$  or  $t_y$ , i.e.,  $|\Omega_{t_a} \cup \Omega_{t_x}| > |\Omega_{t_a} \cup \Omega_{t_y}|$ .

### 3 RESULTS AND DISCUSSION

#### 3.1 Evaluation and Dataset

Consider a set  $L$  of documents or snippets, each containing a reference to a person. Let  $P = \{P_1, \dots, P_{|P|}\}$  be a partition of  $x_i$  and  $zeta$  into references to the same person, so for example  $P_i = S_1, S_4, S_5, S_9$  might be a set of references to "Abdul Razak Hamdan" the information technology professor. Let  $C = \{C_1, \dots, C_{|C|}\}$  be a collection of disjoint subset of  $L$  created by algorithm and manually validated such that each  $S_i$  has a identifier, i.e., URL address, Table 1. Then, we will denote by  $L_C$  the references that have been clusters based on collection. Based on measure were introduced (Lloyd et al., 2005), we define a notation of recall  $Rec()$  as follows:  $Rec(S_i) = (|\{S_j \in P(S_i) : C(S_j) = C(S_i)\}|) / (|\{S_j \in P(S_i)\}|)$  and a notation of precision  $Prec()$  as follows:  $Prec(S_i) = (|\{S_j \in C(S_i) : P(S_j) = P(S_i)\}|) / (|\{S_j \in C(S_i)\}|)$

where  $P(S_i)$  as a set  $P_i$  containing reference  $S_i$  and  $C(S_i)$  to be the set  $C_i$  containing  $S_i$ . Thus, the precision of a reference to Abdul Razak Hamdan is the fraction of references in the same cluster that are also to Abdul Razak Hamdan. We obtain average recall ( $REC$ ), precision ( $PREC$ ), and  $F$  – measure for the clustering  $C$  as follows:

$$REC = \frac{\sum_{\{S_{inLC}\}} Rec(S)}{|LC|} \quad (2)$$

$$PREC = \frac{\sum_{\{S_{inLC}\}} Prec(S)}{|LC|} \quad (3)$$

$$F = \frac{2REC PREC}{(REC + PREC)} \quad (4)$$

### 3.2 Experiment

Let us consider information context of actors, that includes all relevant relationships as well as interaction history, where Yahoo! Search engines fall short of utilizing any specific information, especially context information, and just use full text index search in web snippets. In experiment, we use maximum of 1,000 web snippets for search term ta representing an actor. The web snippets generate the words list for each actor, outputs very rare words because of the diversity its vocabularies. For example, the list of words for a named actor "Abdul Razak Hamdan" generated a list of 26 candidate words. For example, we have as many as 85 web pages about Abdul Razak Hamdan in our dataset. By using Yahoo! Search, we execute the query "Abdul Razak Hamdan" and a keyword "science", then we get 39 web pages that contain the name Abdul Razak Hamdan and a word "science", and in accordance with our dataset. We obtain this value when loading 387<sup>th</sup> web page, and this value persists until the maximum number of loading of web pages, i.e., 500. Thus, we obtain  $Rec("Abdulah Razak Hamdan,science") = 46\%$  and  $Prec("Abdullah Razak Hamdan,science") = 10\%$ . There are 11 words, science, Malaysia, software, data, based, technology, study, computer, using, nor, system, and we have the counting of  $REC = 0.82$ ,  $PREC = 0.23$  and  $F = 0.36$ , see Table 2.

## 4 CONCLUSIONS

The approach based on overlap principle has the potential to be incorporated into existing method for extracting personal feature like as keyword. It shows how to uncover a keyword by exploiting web snippets and hit counts. Our near future work is to compare some methods for looking into the possibility of enhancing this method.

### References

- Bekkerman, R. and McCallum, A. (2005). Disambiguating web appearances of people in a social network, *The Fourteenth International World Wide Web Conference or Proc. Of WWW*, 463-470.
- Bhattachrya, I. and Getoor, L. (2006). A latent Dirichlet model for unsupervised entity resolution, *In Proceedings of the 6th SIAM Conference on Data Mining (SIAM)*, J. Gosh, D. Lambert, D. B. Skillicorn, and J. Srivastave, Eds., 47-58.

Table 2: Recall, Precision, F-measure for Abdul Razak Hamdan

Keyword	Recall	Precision	F-measure
science	0.46	0.10	0.16
Malaysia	0.40	0.20	0.27
software	0.38	0.10	0.16
data	0.30	0.25	0.27
based	0.25	0.26	0.25
technology	0.25	0.28	0.26
study	0.24	0.30	0.27
computer	0.23	0.40	0.29
using	0.20	0.40	0.27
nor	0.15	0.40	0.21
system	0.10	0.40	0.16
Overlap for (2) (3)(4)	0.82	0.23	0.36

- Branting, L. K. (2002). Name-matching algorithm for legal case-management system, *Journal of Information, Law, and Technology (JILT)*, 1.
- Han, H., Zha, H. and Giles, C. L. (2005). Name disambiguation in author citations using a K-way spectral clustering method, *Proceedings of the 5th ACM/IEEE-CS Joint Conference on Digital Libraries (JCSDL 2005)*, Denver, USA, June, 334-343.
- Li, X., Morie, P. and Roth, D. (2005). Semantic integration in text: From ambiguous names to identifiable entities, *AI Magazine*, 26(1), 45-58.
- Lloyd, L., Bhagwan, V., Gruhl, D. and Tomkins, A. (2005). Disambiguation of references to individuals, *RJI0364 Computer Science*, October 28.
- Mann, G. S. and Yarowsky, D. (2003). Unsupervised personal name disambiguation, *Proceedings of Computational Natural Language Learning (CoNLL 2003)*, 33-40.
- McCarthy, D., Koeling, R., Weeds, J. and Carroll, J. (2004). Finding predominant word senses in untagged text, *Proceedings of the 42nd Meeting of the Association for Computational Linguistics (ACL04)*, 279-286.
- Nasution, M. K. M. and Noah, S. A. M., (2010a). Extracting social networks from web documents, *The 1st National Doctoral Seminar on Artificial Intelligence Technology (CAIT)*, Universiti Kebangsaan Malaysia, 27-28 September, 278-281.
- Nasution, M. K. Mahyuddin (2010b). Kolmogorov complexity: Clustering and similarity. *Bulletin of Mathematics*, 3(1), 1-16.
- Nasution, M. K. Mahyuddin and Noah, S. A. M. (2012). Keyword extraction for identifying social actors. *arXiv:1212.3023v1*.



- Nguyen, H. T. and Cao, T. H. (2008a). Named entity disambiguation on an ontology enriched by Wikipedia, *IEEE*, 247-254.
- Nguyen, H. T. and Cao, T. H. (2008b). Named entity disambiguation: A hybrid statistical and rule-based incremental approach, *In ASWC 2008, LNCS 5367*, J. Domingue and C. Anutariya, Eds, Heidelberg: Springer, 420-433.
- Schutze, H. (1998). Automatic word sense discrimination, *Computational Linguistics*, 24(1), 97-123.
- Song, Y., Huang, J., Councill, I. G., Li, J. and Giles, C. L. (2007). Generative models for name disambiguation (*poster paper*), *WWW 2007, May 8-12, Banff, Alberta, Canada: IEEE*, 1163-1164.

# Design XML Web Services As A Data Integration Method Of Between Unit Health Health Surveillance For Support Health Epidemiology Data Warehousing

Slamet SN, Fikri Budiman, Sudaryanto

Universitas Dian Nuswantoro

e-mail: slametalica301@gmail.com, fikri@dosen.dinus.ac.id, musd4rs@gmail.com

## *Abstract*

*Data monitoring disease outbreaks in the region and specific populations (epidemiology) requires the support of a complete and integrated data from each unit surveillance. Integration of data sources between health care units (health centers/puskesmas, clinics, laboratories, hospitals) as a surveillance unit to be managed effectively so as to facilitate the monitoring, analysis and decision making fast to the outbreak of the disease. It is necessary for the management of data centers in the data warehouse to create an integrated surveillance system (Sistem Surveilans Terpadu/SST). The problem faced is interoperability, or the ability to integrate data from different applications platform between the health care unit. To resolve these problems required a method of XML Web Services, which is a method that can integrate applications and data exchange in XML (Extensible Markup Language). Exchange data in XML format using SOAP technology (Simple Object Access Protocol) and WSDL (Web Services Description Language) and using NuSOAP library. Web Services which will bridge the gap platform databases and applications in the context of integration into the data center. NuSOAP used to provide class soap and SoapServer Client or as a listener that will receive and respond to requests for access to web services. The results will be obtained in this study is reporting applications clinic surveillance unit and hospital surveillance unit that can be integrated reporting system on the server data center in public health office (dinas kesehatan) as epidemiological data warehouse.*

**Keywords :** *Epidemiology, Interoperability, NuSOAP, XML Web Services*

## 1 INTRODUCTION

Public health indicators related to the epidemiology of cases in a particular region. So that no widespread epidemic its escalation monitoring system is needed to develop a method to systematically analyze the state of a disease in an effort to cope with rapid and integrated. To the Ministry of Health has issued a ministerial decree No.1479/Menkes/SK/X/2003 about: Guidelines for the Implementation of Surveillance System Integrated Infectious Diseases Epidemiology and Communicable Diseases. In the surveillance guidelines affirm the need for

an Integrated Surveillance System (SST) with the support of standard data where the main epidemiological surveillance system covering all health care surveillance units (health centers, Laboratory, Hospital) at the local government level with the model: Reporting Recording System Integrated Health Center (SP2PT) and Hospital Reporting System (SPRS). Operational implementation of SST on local governments were given to local health authorities to be a system of epidemiological information. But in the implementation and operation of an integrated surveillance system (SST) the level districts / cities facing an obstacle in transferring health data to the health department. This constraint is because the source data from surveillance units scattered and obtained from a variety of applications and database management systems (DBMS) are varied (multi-platform). Synchronization of data interoperability and data integration between health department surveillance unit of the local government level the main problem. Every surveillance unit has lack of uniformity application platform and database (heterogeneous). The problem is principally related to interoperability or the ability to integrate different applications and data between surveillance units. XML Web Service can be a solution.

XML Web Services is a software system designed to support inter-operation of the machine to machine interactions in a network (Erl, 2007). Interaction is done through a specific mechanism or protocol. Thus the ability of web services can increase the ability of the web to communicate and exchange information and data with the pattern of program-to-program. With the design of XML Web Services will be able to integrate systems, programming languages, database and operating system platforms that are different from protocol HTTP (Hyper Text Transfer Protocol), so that different applications between surveillance units can communicate with the data center with good so as to support the epidemiological data warehouse.

The objective of this study is to perform analysis, design, implementation and integration of data synchronization between the data surveillance unit (health centers/puskesmas and hospitals) with the data center (data warehouse epidemiology) in a web-based application model. The benefits of this research is to give an overview of how the steps that must be done and prepared to realize the integration of data between units of surveillance in support of health epidemiological data warehouse.

## 2 RESEARCH METHODOLOGY

This research is a case study for integrating epidemiological data two surveillance units (health centers and hospitals) into data center health department of epidemiology. Data epidemiological surveillance unit used at health center level using standard daily epidemiological report LB1, while the rate of hospital epidemiology data using daily epidemiological report data W1. Epidemiological data used health center level DBMS MySQL DBMS while epidemiology at the hospital level PostgreSQL use traditional DBMS.

1. Requirement Analysis: Studying the database structure epidemiological hospitals and health centers to get the data requirements and data structure epidemiological. Furthermore, in the design of a prototype web service at the health centers and hospitals to manage the epidemiological data that can be integrated with the needs of the data center data base of epidemiology at the health department.
2. Design : The design phase is done by the architectural design of data integration

between the surveillance unit with epidemiological data center . Creating test design synchronization of data transmission units towards the data center surveilans health department epidemiology.

3. Implementation : Furthermore, doing web design services to perform data conversion epidemiology of dbms into text form in XML SOAP . With the data in the DMS soap in fregistrasikan to the needs of receipt and delivery of data services. Programs created with PHP and NuSOAP to make fil WSDL. Simulations carried out by using 3-connected computer, the first computer simulate clinic surveillance, computer b simulate surveillance house saki and computer c simulate data center health department epidemiology.
4. Testing : Testing is done with the parameter functionality, which is done maker epidemiological surveillance report on computer a and b, then run the web services of data transmission that epidemiological data sent and can be monitored results on the level of health services (computer c) . From this test the function of sending data generated by monitoring the results on the data center epidemiology.

### 3 RESULTS AND DISCUSSION

#### 3.1 Design Model Architecture

In the design for application integration architecture to be built with these services webs are epidemiological data integration unit and hospital clinic surveillance. Where the surveillance unit that uses dbms and different applications (My Sql and PostgreSQL). Access will be built in the inter-application communication occurs in both directions, which through web services each surveillance unit will take a local database riding epidemiological data converted into the format of the document in the form of certain parameters (SOAP Services). Then web service to send and request access Atar will forward the application to the health department epidemiology database as a data center epidemiological.

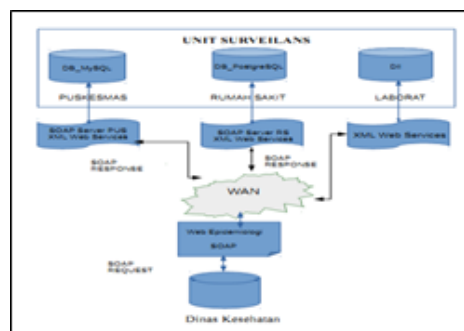

Figure 1: Epidemiology Data Architecture Integration

#### 3.2 Implementasi Web Services

In this study we created a prototype data center (dataware house epidemiology) which obtained epidemiological data sources of health centers and hospitals. The data center will

obtain epidemiological data sources in the process of making XML Web Services, there are several services or functions that were made to access the database. The services that will be on the call and is used to build the system integration of epidemiological reports of health centers and hospitals to the health department epidemiology data center as a unified data base system integrated surveillance (SST).

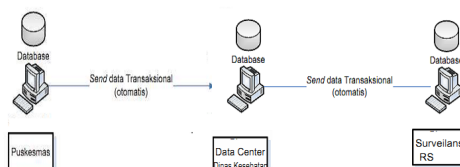

Figure 2: Design of Delivery Function Data between Surveillance Units

The first integration process is to integrate epidemic report LB1 (Puskesmas daily epidemiology format) from a puskesmas to the health department epidemiology data center. Delivery LB 1 has been done manually, so that the data center to work extra to enter data for the subsequent conduct of epidemiological data processing. The process of data transmission is done on a daily. By creating services that can integrate epidemiological data automatically into data center health department would have an impact of efficiency in processing and analyzing epidemiological data as well as integrated with other Surveillance units.

Algorithm making of services WSDL for epidemiological data from surveillance unit can be seen as shown below.

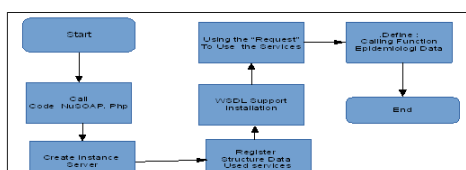

Figure 3: WSDL Services Getting Data Surveilans Algorithms

Step algorithms of making such services are:

1. The first step in programming WSDL is calling NuSOAP code which is a PHP class to send and receive SOAP messages over HTTP using needs (nusoap.php).
2. Next create a server instance: `$ server = new soap_server ();`.
3. Do initialization WSDL Support: `$ server -i configurWSDL ('AServer', 'urn: Aserver).`
4. The next step is to register epidemiological data structures used by these services (Services: `$ services-$ i wsdl-$ i addComplexType`) in the format of LB1 and W1 into an array (registers ('surveaailans', array ('param', tns: typeDataInput), array ('return' -\$ i xsd: string ')).
5. The final step is to define a function call epidemiological data from surveillance unit and use the request for services: `$ server -i services ($ HTTP_RAW_POST_DATA).`

### 3.3 Result of Integration of XML Web Service

Prototype integration of data center that was developed at the health department is the integration of the two units of surveillance that health centers and hospitals. To design XML Web Services data from two surveillance units can be unified into a system that are integrated although originating from different applications and dbms (multi-platform). Figure below shows the number of data reports epidemiological information sourced from health centers and hospitals.

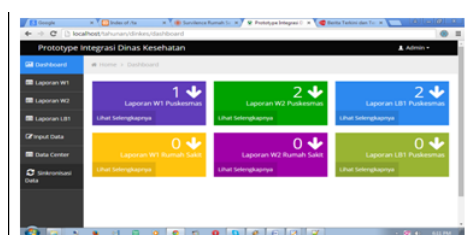

Figure 4: Pages on Information Epidemiology Data Center Dinkes

To monitor the epidemiological data transmission from the surveillance unit shipment data synchronization can be performed on each unit of surveillance every day or per date. With this daily monitoring system will be able to ensure the surveillance unit anywhere that does not perform epidemiological data transmission so that it can be done a certain action, It is very important to monitor epidemic especially for epidemics and infectious diseases.

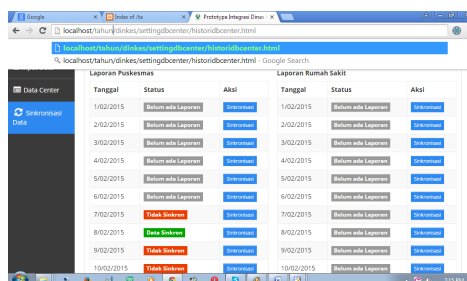

Figure 5: Page Data Center Monitoring Data Reporting Epidemiology

## 4 CONCLUSION

In this study has been conducted services web design development with XML and has conducted testing of prototype data center epidemiological dinkes which epidemiology data sources derived from epidemiological data reporting daily health centers (LB1) and daily epidemiological data reporting hospitals (W1). From the test results of the prototype data center epidemiology, web design service successfully integrated reporting system of units surveillance although epidemiological data sources come from different applications and dbms (MySQL and PostgreSQL). This shows the communication protocol middleware web service that is

capable of performing as a message epidemiological data exchange by using the HTTP protocol, with a computer network between web-based and database application between surveillance units with database data center health department epidemiology. Integration between surveillance units with web services technology in computer networks also shows communication between providers and services requester services can be used for monitoring the delivery of data in real time, so it can be designed application monitoring and effectively synchronize data transmission.

## References

- Ahmadi, A., (2007), Implementasi Web Services pada Content Management Sistem. *Tesis*.ITB Central Library, Bandung
- Booch, G., Maksimuchuk, R., Engle, M., Young, B., Conallen J., Houston, K., (2007), *Object Oriented Analysis and Design with Application*, Pearson Education Corporate, Boston.
- Boy, S., (2003), *Sistem Informasi Manajemen Rumah sakit*, Editor Berkas, Tim Konsorsium, Cetakan 1, Yogyakarta.
- Daconta M.C., Obrst L.J., dan Smith, K.T., (2005). *The Semantic Web: A Guide to the Future of XML, Web Services, and Knowledge Management*, John Willey
- Erl, T. (2005). *Service Oriented Architecture: Concepts, Technology, and Design*. Indiana: Prentice Hall PTR.
- Fowler, M., (2003), *UML Distilled, A Brief Guide To The Standart Object Modelling Language*, Pearson education Corporate, Boston.
- Gottschalk, K., Grahan, S., Kreger. H., dan Snell, J., 2002, Introduction to Web Services Architecture, *Journal IBM Systems Journal* Vol 41, No. 2.
- Guruge, A., (2004), *Web Services: Theory And Practice*, Digital Press, Boston.
- Hori, M., Ohashi, M., Suzuki, S., (2006). Citizen-centric approach and healthcare management based on the xml web services, *Electronic journal of information systems evaluation*, 8(3):179 186.
- Jorgensen, David, (2002), Developing .Net Web Service with XML. Syngress, <http://www.nusphere.com>, diakses tanggal 06 september 2010.
- Huang, D., (2004), *Integrating Web Services with competitive Strategies: The Ballanced Score-card Approach*.
- Mawarni, B.E. (2006). *Pengembangan XML Web service (Studi Kasus Situs Web Info Lowongan Kerja)*. Penelitian Tidak Terpublikasi. Yogyakarta: Magister Teknologi Informasi Universitas Gadjah Mada.
- Putra, A. (2009). *Perancangan Prototype Sistem Informasi Perizinan Penelitian berbasis SOA (Service Oriented Architecture)*. Penelitian Tidak Terpublikasi. Yogyakarta: Magister Teknologi Informasi Universitas Gadjah Mada.

- Pressman, R., (2001), *Software Engineering: a Practitioners Approach*, Fith Edition, McGraw-Hill Companies, Inc.
- Rasdiyanti. (2008). *Pengembangan Database Sarana Pelayanan Kesehatan dan Tenaga Kesehatan Di Dinas Kesehatan Kabupaten Buton*. Penelitian Tidak Terpublikasi. Yogyakarta: Program Pasca Sarjana Fakultas Kedokteran Universitas Gadjah Mada.
- Robby, O.K., Wardana, F.M. (2009). *Analisis dan Perancangan Basis Data untuk Mendukung Aplikasi ERP Education pada Bina Nusantara University (Studi Kasus: Academic Management and Content Preparation)*. Penelitian Tidak Terpublikasi. Jakarta: Bina Nusantara University.
- Rusiawan, FX., (2004), Penerapan Web Services dalam Konteks Enterprise Application Integrateion (EAI)pada Industri Proses. *Tesis*, ITB Central Library, Bandung.



# Study of Wavelet Transformation Method for feature Extraction Characteristics Based In Identifying Authenticity Indonesian Batik

**Fikri Budiman**

Universitas Dian Nuswantoro  
e-mail: fikri.budiman@dsn.dinus.ac.id

## *Abstract*

*Batik is the cultural heritage of indigenous peoples in Indonesia. The original Indonesian batik cap and tulis has a characteristic in the production process that uses a technique closing malam / wax from wax-resist dyeing process. Currently developing the promotion and online sales through cyberspace. To help viewers and consumers cyberspace recognize the authenticity of Indonesian batik, so in this paper, the authors will review the image processing to be able to recognize batik photo circulating in the virtual world is an original photo of Indonesian batik or not. This is done to discuss and review studies feature extraction prior to recognize characteristic motif using wavelet method.*

**Keywords :** batik, feature extraction, wavelet

## 1 INTRODUCTION

Batik from Indonesia received international recognition by UNESCO on October 2, 2009 as "Reperesentatif List of the Intangible Cultural Heritage of Humanity". In this case UNESCO recognized batik is not the object, but what distinguishes the batik from other countries is technically unique manufacturing process using the closing malam / wax with a canting and cap, as well as produce a pattern in the form of a cultural symbol that became a philosophy of life and identity of the people Indonesia.

One attempt to introduce the authenticity of Indonesian batik on e-supermuseum Indonesian batik (budiman, 2012a) designed an e-museum merging function with the e-marketplace, in an e-museum (budiman, 2012b) can provide knowledge about the authenticity and beauty of the motif of Indonesia to visitors online. But at this e-supermuseum consumer has not received assurance of authenticity of products sold batik artisans in the virtual stalls contained in the e-marketplace, this is because the products offered batik craftsmen online only through media images. Of the batik photo consumers can not see whether the results from the process of batik cap, canting, or screen printing (printing). Printing, screen printing, and through painting techniques have also been carried out in the process of making batik or patterned fabric by other countries, so it is not characteristic of batik from Indonesia. Thus,

to provide customer satisfaction in online shopping batik needed software that can distinguish batik produced from the cap, tulis, or printing of a photograph of batik.

Results interview with the curator of the museum batik batik solo Danarhadi (budiman, 2012a) that the authenticity of batik and write can be seen easily because it almost has a front and rear color brightness are almost the same, this is what distinguishes the batik printing or screen printing has a bright color only on the front side. But this can not be seen through the images show only one side. Batik and writing can also be seen from the nearby has a distinctive character strokes, namely the edge image is not perfect due to overtopping or color leakage at the closing malam / wax from wax-resist dyeing process. This is what can be the problem so it can be raised in this study to be able to recognize the authenticity of batik tulis, cap, and printing through media images using image analysis with the introduction of the character and characteristics of the leakage rate pattern color of the outline drawing on batik tulis, cap, and sablon (printing).

## 2 BATIK PATTERN RECOGNITION

Digital image processing research in batik today is to recognize the pattern motif (Rangkuti et al, 2014; putra et.al, 2011; Imanuddin et al, 2010; moertini and sitohang, 2005). Indonesia is rich motif that required recognition motif based on the region of origin to identify the origins of batik (Rangkuti et al, 2014).

Batik in Indonesia is recognized worldwide through UNESCO is not the object of batik, but the unique manufacturing process hereditary and contains original Indonesian culture philosophy (budiman, 2012a). Manufacturing process by hand using canting or cap to cover the fabric with malam (wax), so that the cloth that covered the wax is not affected by the color in the color by dipping a cloth in a vessel containing drugs color, it is called with the wax -resist dyeing. The process of making the canting called batik tulis, and with a cap called batik cap.

Batik tulis and cap the original write hereditary made in Indonesia. With the development of time to simplify the process and reduce the price of emerging batik sablon (printing) processes. To distinguish it can be seen directly on batik and cap both sides of the fabric has a color that is almost as bright as through the process of dyeing color, but the only bright batik color printing on one side. In a previous study (budiman, 2012a), has not been able to verify the authenticity of batik through media images in e-marketplace. Further research is to be able to analyze the texture through the photo media characterize the pattern and color leakage rate in the region given the closure of wax. In Batik has a distinctive character because it is done by hand, so that at the edges of the image motif is not too neat, there is overflow or leakage of colors that penetrate the cover of night / wax, this does not happen at the edge of the motif batik printing where the image is very symmetrical and neat.

## 3 FEATURE EXTRACTION

Batik is a unique characteristic feature of an object image batik. So, we need to be able to distinguish the feature extraction or recognize a batik. In the feature extraction acquired traits distinguishing objects that have to be used as the data set and used in pattern recognition training.

Introduction authenticity and cap batik is very dependent on the quality of feature extraction, to obtain the characteristics karakteristik batik motif or pattern images to generate

the data set of training with a good degree of accuracy, it is very influential in getting the recognition motif texture analysis for quality. Features a unique characteristic of the characteristics of the texture of the image to be recognized by digital image processing. Feature extraction is performed to find the area that has the characteristic features in the image, the region can didibedakan based on the characteristics of color, shape, texture, size, intensity, or statistical properties. Statistical characteristic features commonly used is standard deviation, correlation, contrast, energy, entropy, and homogeneity.

To measure the characteristics of the texture is done with the method of analysis which is a fundamental feature extraction in image analysis (nixon and Aguado, 2008). Feature extraction is done after the Region of Interest (ROI) is known from the results of the pre-process and segmentation. The results of the statistical characteristic feature extraction form will be used for the classification stage recognition phase. Statistical characteristic features commonly used is standard deviation, correlation, contrast, energy, entropy, and homogeneity. Methods for generating unique characteristic traits of the few studies using wavelet transform method, such as used for recognition motif (Rangkuti et al, 2014; son et.al, 2011; Imanuddin et al, 2010; moertini and Sitohang, 2005). Wavelet transform method is suitable for feature extraction applications involving signals or data that a-periodic, discontinuous (intermittent), full of noise (noisy), and transients. In wevelet transformation time analysis with different frequency from STFT (Short-Time Fourier Transform), and a family of functions generated by wavelet bases  $\psi(x)$  is called the mother wavelet and develop into a variety of methods based on wavelet transform to the analysis of data on the extraction features. Wavelet transformation process data in the form of other changes are more easily analyzed.

As far as I read to study texture analysis and image classification is applied to determine the authenticity of Indonesian batik from a photograph has not been performed, previous studies merely perform pattern recognition motifs native Indonesian batik (Rangkuti et al, 2014; son et .al, 2011; Imanuddin et al, 2010; moertini and Munaf, 2005). Introduction motif identification dilakukan to show the origin of batik (Rangkuti et al, 2014) with a unique texture and shape of the motive, so it can be made to match to identify the origin of the characteristics of the target image in the image database. In that study (rengkuti et al, 2014) in analyzing the character of the texture used Daubechies wavelet transform method type 2 and invariant moment. In the study (moertini and Sitohang, 2005), the use of multiple algorithms dilakukan to determine the performance of the algorithm is good for cluster and batik classification based on color, contrast, and motifs to match the consumer's personal appearance batik. In research Imanuddin (Imanuddin et al, 2010) was limited to categorize motif pattern features in the database by region of origin using morphological processing with methods dilation and erosion, it is also done in the study (putra et al, 2011) with the extraction batik using wavelet transform with a combination of discrete wavelet transform and rotate wavelet filter can produce a more optimal accuracy characteristics compared to using separately.

Character recognition research models the number of pixels of color leakage at the edges of the image batik pattern to produce a dataset based on the class in accordance with batik features, cap, and printing it refers to previous research related to texture analysis algorithm for the extraction and classification pixel based image penyepadanan pattern edge of the image, as shown in Table 1.

Table 1: Related Journals

Researcher name	Research themes	Method	Advantages	Disadvantages
Moertini, Veronica S., Sitohang, Benhard. (2005)	Batik classification based on color, contrast, and motives.	Classification Motif combining Shape-bases using mask and texture-bases using wavelet method. With the classification using the K-Nearest Neighbor.	Analysis of the development of algorithms is done in detail by comparing eight kinds of wavelet algorithms. And can be used to test on other issues.	The duration is not too high, and only in test them with a range of sizes and ornaments, not in the detailed test them on motives.
Putra, Ricky Eka., Suciati, Nanik., Wijaya, Arya Yudhi. (2011)	Motif batik documenting.	Texture feature some combination of DWT and RWT. By using the classification method Canberra Distance.	Merger better than the DWT or RWT only.	Results of average accuracy of 70% is required classification by other methods (MLP, SVM, etc.). Only 5 motifs tested.
Arisandi, Bernardinus., Suciati, Nanik., Wijaya, Arya Yudhi. (2011)	Introduction batik motif based image spatial and frekuensi.	Feature extraction by decomposition using wavelet transformation (DWT + RWT). And classification with Neural Network Multilayer perceptron variant.	Classification of multilayer perception can be overcome massive parallelism in wavelet decomposition results more quickly.	Accuracy is still low for testing data that is different from the training data.
Rangkuti, A., Haris, Harjoko, Agus., Putro, Agfianto Eko. (2014)	Batik motif Characteristics	Using the wavelet decomposition method with four statistical parameters and variants moment. Classification using fuzzy S Curve.	Made more specific wavelet method using wavelet transform method daubeches type 2 and invariant moment.	Not to use the unique features for image identification. Optimal precision below 95%
Rangkuti, Abdul Haris. (2014).	Image classification for the texture characteristics.	Wavelet Decomposition with three statistical parameters. Classification using Fuzzy Neural Network.	Optimizing precision reaches 95%. simplify parameters without entropy.	Need to be tested kekarakteristik picture is more complicated and complex.

## 4 CONCLUSION

From the description above it can dilakukakan research is to develop a model approach to feature extraction through statistical parameter characteristic features with wavelet method, and can be used as a data set that contains the characteristics of texture as a distinguishing characteristic color leakage at the edges of the image batik pattern, cap, and printing. To measure the effectiveness of problem-solving skills can be compared again with the combine wavelet-based texture or by any other method of neural network, GLCM (Gray Level Co-occurrence Matrix), and edge detection.

Good extraction results will largely determine the success of the classification in pattern recognition. With the initial development for introduction and cap batik as Indonesian nation's indigenous culture will produce a contribution to the field of information technology culture in the form of software applications that can provide information to consumers about the authenticity batik offered by e-commerce or e-marketplace with media images. And to contribute to the field of science is the development of the application of the model in classifying batik pattern recognition based on the production process by measuring the unique characteristics as a characteristic texture based on the shape and the number of points widening the color of the edge image patterns of batik.

## References

- Arisandi, Bernardinus., Suciati, Nanik., Wijaya, Arya Yudhi., (2011), *Pengenalan Motif Batik Dengan Rotated Wavelet Filter Dan Neural Network*, Jurusan Teknik Informatika, Fakultas Teknologi Informasi, Institut Teknologi Sepuluh Nopember.
- Budiman, Fikri., Sudaryanto, Slamet., Susanto, Ajib., (2012), *Rekayasa Model Supermuseum Batik Online Untuk Mengenalkan Keanekaragaman Motif Batik Tradisional di Indonesia Dalam Upaya Meningkatkan Pemasaran Batik Produk Usaha Kecil dan Home Industri*. Penelitian Hibah Strategis Nasional, DP2M Direktorat Jendral Pendidikan Tinggi Pendidikan Nasional.
- Budiman, Fikri., (2012), *Rekayasa Model Museum Batik Online Untuk Mempopulerkan Warisan Budaya Motif Batik Tradisional*, *Proceding Konferensi Nasional Sistem Informasi*, STIKOM Bali.
- Imanuddin, (2010), *Batik Identification Based On Batik Pattern And Characteristics Using Fabric Pattern Feature Extraction*, Undergraduate Program, Faculty of Industrial Engineering, Gunadarma University.
- Moertini, Veronica S., Sitohang, Benhard, (2005), *Algorithms of Clustering and Classifying Batik Images Based on Color, Contrast and Motif*, *PROC. ITB Eng. Science* Vol. 37 B, No. 2, 2005, 141-160.
- Putra, Ricky Eka., Suciati, Nanik., Wijaya, Arya Yudhi., (2011), *Implementing Content Based Image Retrieval For Batik Using Rotated Wavelet Transform And Canberra Distance*, *Articles Bali International Seminar On Science And Technology*, Bali-Indonesia.
- Rangkuti, A., Haris, Harjoko, Agus., Putro, Agfianto Eko, (2014), *Content Based Batik Image Retrieval*, *Journal of Computer Science* 10 (6): 925-934, Science Publications.

Rangkuti, Abdul Haris, (2014), Content Based Batik Image Classification Using Wavelet Transform And Fuzzy Neural Network, *Journal of Computer Science* 10 (4): 604-613, Science Publications.

## Survey on Development Method of Ontology

Ria Andryani, Edi Surya Negara

Universitas Bina Darma

e-mail: ria@mail.binadarma.ac.id, e.s.negara@mail.binadarma.ac.id

### *Abstract*

*Ontology has strategic function in developing web based on knowledge. To develop the ontology, there is much methodologies which suggested by the researchers. This article will discuss and describe methodology methodology which has been developed in current decades. The methodologies are covered into many forms, such as: Uschold Methodology, Grninger and Fox Methodology (TOVE), METHONTOLOGY Methodology, IDEF5 Methodology, Ontolingua Methodology, SENSUS Methodology, CYC Mehtodology, Mikrosmos Methodology, PLINIUS Methodology, CommonKADS and Kactus Methodology, ONIONS Methodology (Ontologic Integration Of Naive Sources), On-To-Knowledge methodology, MENELAS Methodology, PHYSSYS Methodology, 101 Methodology, UPON Methodology (Unified Process for ONtology building), BORO Methodology.*

**Keywords :** *Ontology, Development Method*

## 1 INTRODUCTION

Development and growth of ontology tend to strategic technique in developing knowledge based on system. Looking to the previous relevant research, there is much advantages which got from development of ontology, such as: a) knowledge sharing, b) re-using knowledge, c) innovation and acquisition on knowledge based on system, d) verification and maintenance, etc. Development knowledge based system refers to the design of web technology in the future. Explicitly, ontology determines concepts to development of knowledge based web. Moreover, the ontology has strategic role to develop application based on knowledge.

In information study, according to Smith (2003)[19] definition of ontology is term which formulated in canonical syntax and it will be designed to produce lexical conceptual or taxonomy to represent the knowledge that functioned to the different information system. Therefore, this article will discuss methodology the methodology on development of ontology in current decades. Moreover, this study will analyze each methodology by looking the criteria which has been determined and it will give deep concept which important to the current methodology.

## 2 LITERATURE REVIEWS

Nowadays, there is much ontology development method which specific to cover problems on ontology development. For this case, the writer will show survey method the method which is used to ontology development.

### 2.1 Uschold Methodology

Uschold Methodology has been developed by Mike Uschold and Martin King in 1995 [21]. Uschold Methodology refers to first methodology which develop to development enterprise ontology[4]. This methodology gets four phases to develop the ontology [21], , namely:

- Identify Purpose
- Building the Ontology
  - Ontology Capture
  - Ontology Coding
  - Integrating Existing Ontologies
- Evaluation
- Documentation

### 2.2 Grninger and Fox Methodology (TOVE)

Grninger and Fox Methodology or TOVE Methodology has been developed by Michael Gruninger and Mark S. Fox in 1995[10]. This methodology has offered to cover TOVE (Toronto Virtual Enterprise) project and it is used to develop methodology on - toloy which tends to business domain. In first phase, this methodology focuses to create regulations on ontology by handling informal description. Furthermore, it is used to transform the informal order to formal order. For this case, the first case can be called as logic ontology model [22]. Motivation scenario is used to get semantic which describe in informal order. The description and formulation have been created by first-calculus order. By composition and de-composition, it will help to integration the ontology. In deep, the procedure and evaluation of the ontology can be seen in figure 1.

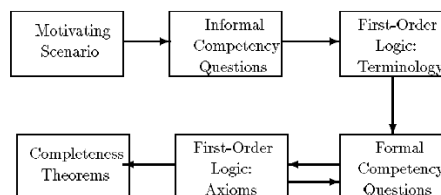

Figure 1: Procedure to design and evaluation the ontology (TOVE)



## 2.3 METHONTOLOGY Methodology

METHONTOLOGY Methodology is a structured method which functioned to create the ontology in the beginning form. [7]. METHONTOLOGY explains the activities and techniques which needed in partial way. To develop the creating ontology in knowledge level and to follow cycle life based on development prototype. The methodology covers the activities which oriented to development, which is specification, conceptualization, formulation, integration, and implementation, such as in the figure 2. METHONTOLOGY Methodology offers development prototype as cycle life which is compatible with ontology of life. The cycle allows to decrease or modification of definition in many situation. It is also allowed to develop knowledge acquisition, evaluation, integration, and documentation. Moreover, it has been tested by developing the ontology for the others domain, such as chemistry materials[7].

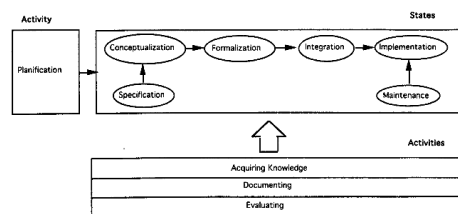

Figure 2: Parts and activities on METHONTOLOGY Methodology

## 2.4 IDEF5 Methodology

IDEF5 Methodology tends to methodology which developed based on development prototype model and independent application [11]. This methodology supports to maintenance phases through two languages order. In the beginning, the ontology is known by using schema language and it looks for graphic notion which describe general information of ontology. The language schematic is used as communication tools between expert domain and the ontology developer. But, the language is used in the first order later it analyze and transform into structural language based on KIF [11]. In the simple way, the process of development IDEF5 ontology includes into five activities, such as following elaboration. [11]

### 1. Organizing and Scoping

This activity includes into determining the goals, concepts, and context to development ontology project and sharing application and function for each members of team.

### 2. Data Collection

This activity aims to get authentic data which needed to develop the ontology.

### 3. Data Analysis

This activity aims to analyze data in order it is able to extract the ontology.

### 4. Initial Ontology Development

This activity includes first ontology development from data that got by the team.

## 5. Ontology Refinement and Validation

This activity refers to the part of re-check and validation of the ontology to solve the process of development.

## 2.5 Ontolingua Methodology

Ontolingua Methodology is a methodology ontology which shows a usefully concept. The ontology defines term which oriented to the object and language frame. On-tolingua server has expanded the source language in two ways. First, it gives explicit link to create possible ontology module, later it expands and keep into new ontology. Second, it allows generating certain lock between presentation and representation ontology [5].

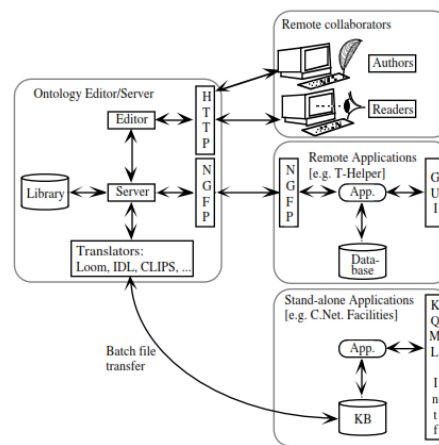

Figure 3: Architecture of Ontolingua Server

Phase Development Ontolingua Methodology [5] :

1. Browsing Ontologies
2. Building Ontologies
  - (a) Maintaining Ontologies
  - (b) Sharing Ontologies
  - (c) Collaboratively Developing Ontologies
  - (d) Ease of Use
3. Using Ontologies

## 2.6 SENSUS Methodology

SENSUS Methodology is a methodology which support to the concept reusability, redesign and both of them links with natural language processing (NPL) domain, it likes concept on Ontolingua Methodology. SENSUS Methodology has been developed by using many sources, such as: PENMAN Upper Model, ONTOS, WordNet and many e-dictionary (English, Spanish

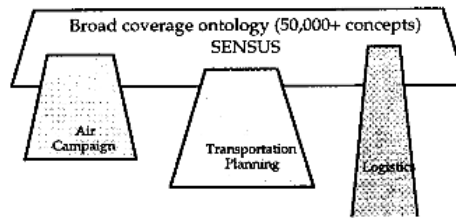

Figure 4: Links between Domain at SENSUS Methodology

and Japanese)[18]. In the figure 4 has been showed the links between domain and prerequisite on SENSUS Methodology.

SENSUS Methodology runs by looking these steps: 1) identify important terminologies (seed); 2) create link terminologies to Sensus manually; 3) add the node from path to root; 4) re-add sub-tree with rules heuristic if much node in a relevant sub-tree meaning [22]. SENSUS Methodology offers a basic concept of hierarchy structure in which the term is used as proof in expressing Interlingua to translator machine. The term of abstract on hierarchy show the linguistic generalization even the term middle and low levels have been familiar or daily terminologies [18]. See figure 5.

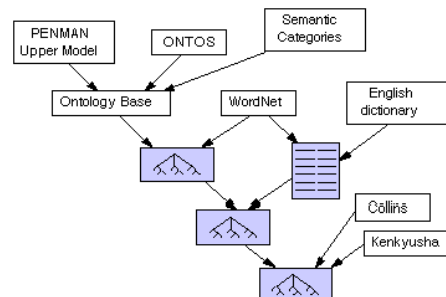

Figure 5: Combination Strategy by SENSUS Methodology

## 2.7 CYC Methodology

CYC Methodology is a methodology which developed based on knowledge. Ontology is core component from CYC Knowledge [12]. In developing, CYC methodology gets three phase [6], namely:

- First phase offers manual coding, implicitly and implicitly in source knowledge without supporting from natural language and learning system. This phase is done manually because natural language and learning systems cannot explore general or new knowledge.
- Second phase offers re-coding knowledge which support by tools knowledge on CYC Knowledge base.

- Third phase determines delegation to create tools. The people just will recommended source of knowledge which possible to read, and they will explain difficult part from the text.

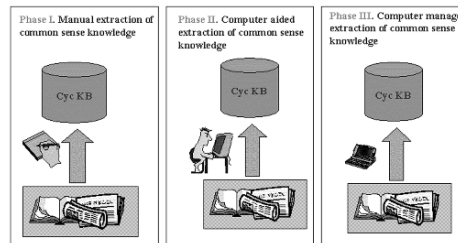

Figure 6: Building phase of CYC Knowledge Base

## 2.8 Mikrosmos Methodology

Mikrosmos methodology is ontology development which includes into natural language processing (NLP) development, and machine translation (MT) [13]. Ontology on natural language processing (NPL) tends to the concept of knowledge which explores: a) repository symbol primitive to present a meaning, b) regulator symbols which subsumption hierarchy, and c) inter-connection symbols with semantic systems. In deep, this ontology looks as database into the following information [13]:

1. what categories (or concepts) exist in the world/domain,
2. what properties they have,
3. and how they relate to one another

In machine translation (MT), the main reasons to use ontology are following elaboration: [13]

1. Give a basis to delegate meaning of text in Interlingua.
2. To activation lexicons for different languages, especially to share knowledge.
3. To analyze source language and target language in sharing knowledge.

## 2.9 PLINIUS Methodology

Plinius Methodology is a ontology method which extracts semi-automatic knowledge from natural language text. Plinius ontology is developed to support the translating sentences from natural-language to expression on knowledge representation language [14]. The principles to create the ontology are following explanation.

1. The opposite statements with entity can find in easy way if the concept has been showed maximally.

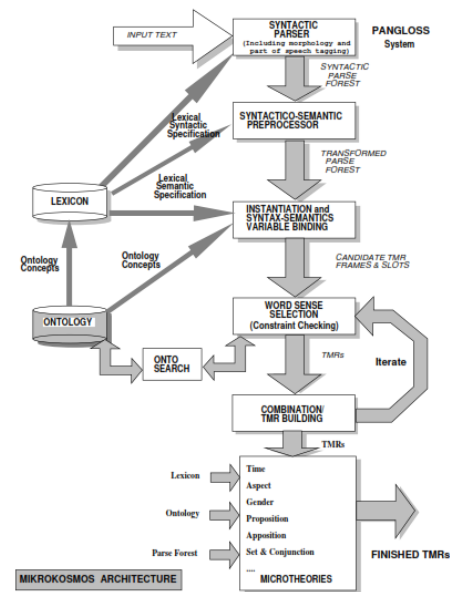

Figure 7: Mikrokosmos Methodology at NLP Architecture

2. The previous formal theory is got and the domain of ontology cannot determine the logical construct from semantics.
3. Ontology should independent from knowledge representation language.
4. Conceptual principle should construct to show the ontology has been arranged from primitive concepts and regulation construction which shows the others primitive concepts.
5. An approach bottom-up is taken to show the complete ontology that should be filled.
6. The ontology development should be created based on policies of innovation, such as: policy about cost-benefit analysis.
7. The ontology should evaluate from completely work view.

## 2.10 Common KADS and Kactus Methodology

CommonKADS and Kactus Methodology is development project which focuses on ontology development issues. Innovation approach on ontology adopted which look to modular design. [2]. The ontology is developed from a library in small scale which map between the old ontology and the new one. Kactus Methodology gets many phases, such as following statements [1]:

1. Specification from application;
2. First design base on top-level ontology;
3. Finishing and re-constructing ontology.

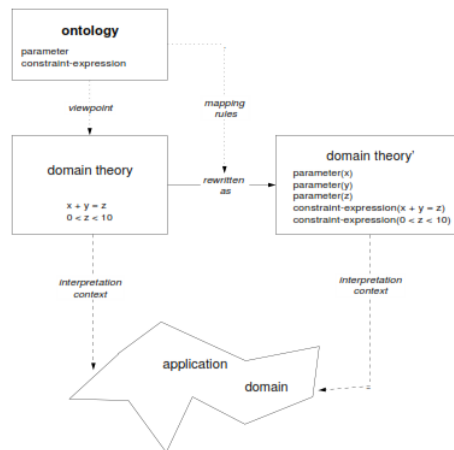

Figure 8: Ontology as meta-model which describes domain theories on CommonKADS and Kactus Methodology

## 2.11 ONIONS Methodology (Ontologic Integration Of Naive Sources)

ONIONS Methodology is development method which develop by motivation to integrate sources of information which heterogenic in knowledge acquisition. For this case, the specific aspect in ONIONS approach is ontology acquisition method. This acquisition will produce non-formal ontology. Furthermore, the following elaborations tend to show phases of ontology development based on ONIONS Methodology [9].

1. Phase I
  - (a) Extraction of source terms
  - (b) The medical sources
2. Phase II
  - (a) Local (or surface) definition of terms
3. Phase III
  - (a) Multi-local (or shallow) definition of terms: triggering theories related to distinctions made in local definitions
4. Phase IV
  - (a) Multi-local (or shallow) definition of terms: triggering theories for top-level categories design
  - (b) A guide in the general ontology forest: the ontological frame of a State of Affairs
5. Phase V
  - (a) Multi-local (or shallow) definition of terms: merging local definitions and top-level categories

## 6. Phase VI

- (a) Formalization of an Integrated Model
- (b) The current state of the implemented medical ontology as an output of ONIONS

### 2.12 On-To-Knowledge methodology

On-To-Knowledge methodology shows an approach which aims to make balancing between human solve problem and automatic IT solution. This methodology focuses on knowledge of meta- process and knowledge process. [20]. On-To-Knowledge methodology has many phases like following statements [20]:

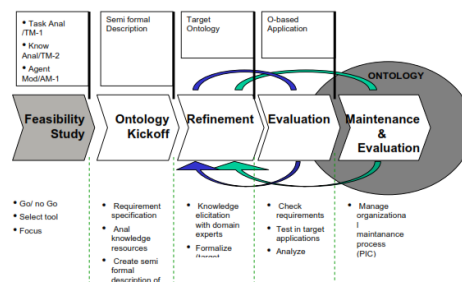

Figure 9: On-To-Knowledge (OTK) Methodology

1. Feasibility study,
2. Ontology kickoff,
3. Refinement,
4. Evaluation and refinement-evaluation.

### 2.13 MENELAS Methodology

MENELAS Methodology tends to ontology method which design as part of natural language system in medical domain [3]. This method has developed by using graphic concept as the core formal. MENALAS gets four principles to develop taxonomy knowledge, namely: similarity, specifies, opposition, and access unique semantic. All of them are used to support acquisition control and re-form ontology. But, this methodology has point of view that ideal taxonomy which affects it incompatible for others domain.

### 2.14 PHYSSYS Methodology

PHYSSYS Methodology tends to ontology development which uses to solve problem in e-library. This method aims to facilitate the choosing to current ontology method based on construction dynamic knowledge. There are two types of this ontology, namely:

1. Primary (domain from many views)
2. Secondary (shows the others distinction from the object)

## 2.15 101 Methodology

101 Methodology is ontology method which used to develop ontology domain [16]. The phases on ontology development of 101 Methodology are following statements:

1. Defines class on ontology,
2. Arranges the class into subclass and super-class hierarchy taxonomy.
3. Defines slot and describes values which allows to slot.
4. Analyze the value of slot.

## 2.16 UPON Methodology (Unified Process for ONtology building)

UPON is ontology development method which comes from Unified Software Development Process[15]. UPON Methodology uses Unified Process (UP) and Unified Modeling Language(UML) to support planning of Blue Print on a project ontology. UPON is developed to facilitate the user even human or automatic system to produce ontology.

UPON get cycle, phase, iteration, and work procedures. Every cycle includes with four phase, namely: a) inception, b) elaboration, c) construction and d) transition. Every phase has divided into iteration. For each iteration, there are five work procedures, namely: a) requirements, b) analysis, c) design, d) implementation and e) test [15].

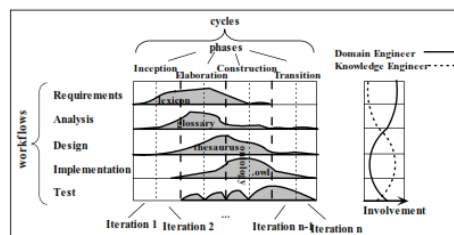

Figure 10: UPON Framework

## 2.17 BORO Methodology

BORO Methodology is an approach to develop model of ontology or semantic for wide complex operational application which include of ontology and process in developing ontology. This methodology, in the beginning, it is developed as method to determining ontology from legacy system it is used as first phase to transform architecture [8] or modernization of software. For this case, it is also used to allow semantic inter-operation between legacy systems. In fact, it tends to analyze method for development and maintenance on civil defense department of AS Architecture Framework (DoDAF) Meta Model (DM2).

BORO Methodology is cycle processes which develop formal ontology in simple way. This method takes extensional approach to develop ontology. The advantages of BORO from the others method is to have foundation in physic reality. It means that this method always produces similar ontology if it get similar stimulus [8]. For this case, BORO rise to be filled



to compare with many sources of semantic comparison/ un-similar and to re-innovate many legacy systems to be a unity or coherent (it tends to new monolite or many methods which design current federation system). The development BORO methodology aims to improve information quality and model information, to integrate sources of information and extract hidden semantic [17].

The aims of this method is to re-engineer the others sources of data into general model [8]. For this case, it gives benefit point at semantic analyze and it determines whether two concepts are similar, whether if they are controversial, or whether they are not link each other. In other side, traditional method of analyze data tends to linguistics and comparison concepts based on label concepts. This method tends to modern that shows in semantically in which analyze will tend to analysis meaning behind the word. But, this method tends to produces accurate comparison and wider, according to domain analyzes knowledge and linguistic interpretation [17].

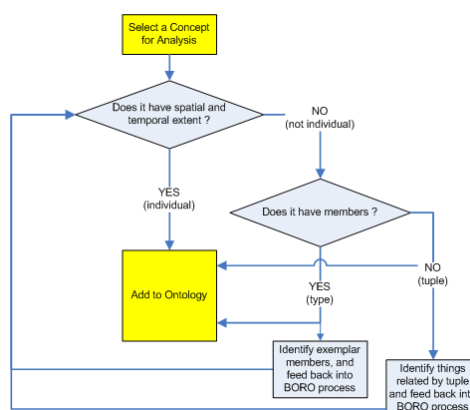

Figure 11: BORO Methodology

### 3 CONCLUSION

This article has been discussed several ontology development methodology, including the Uschold Methodology, Grninger and Fox Methodology (TOVE), METHONTOLOGY Methodology, IDEF5 Methodology, Ontolingua Methodology, SENSUS Methodology, CYC Mehtodology, Mikrosmos Methodology, PLINIUS Methodology, CommonKADS and Kactus Methodology, ONIONS Methodology (Ontologic Integration Of Naive Sources), On-To-Knowledge methodology, MENELAS Methodology, PHYSSYS Methodology, 101 Methodology, UPON Methodology (Unified Process for ONtology building), BORO Methodology. ontology development methodology is a guideline in developing ontology. There are some advantages and disadvantages of each - each methodology. Degree of maturity of the methodology of the discussion above with order maturity is OTK, Methontology, Grninger & Fox, Uschold & King, Census and Kactus. Census has a very different approach compared to other methodologies. This condition refers to the further research in order to develop a methodology that more mature is important.

## REFERENSI

- [1] A. Bernaras, L. Laresgoiti, and J. Corera, "Building and reusing ontologies for electrical network applicationh," in 12 th European Conference on Artificial Intelligence, 1996, pp. 298–302.
- [2] G. S. Bob, B. Wielinga, and W. Jansweijer, "The kactus view on the 'o' word," in In IJCAI Workshop on Basic Ontological Issues in Knowledge Sharing, 1995, pp. 159–168.
- [3] J. Bouaud, B. Bachimont, J. Charlet, and P. E. Zweigenbaum, "Acquisition and structuring of an ontology within conceptual graphs," in Proceedings of Workshop on Knowledge Acquisition using Conceptual Graph Theory, 1994.
- [4] O. Corcho, M. Fern, and A. Gomez-perez, "Methodologies, tools and languages for building ontologies. where is their meeting point," *Data & Knowledge Engineering*, vol. 46, pp. 41–64, 2003.
- [5] A. Farquhar, R. Fikes, and J. Rice, "The ontolingua server: a tool for collaborative ontology construction," *International journal of human-computer studies*, vol. 46, no. 6, pp. 707–727, 1997.
- [6] M. Fernandez-Lopez and A. Gomez-Pérez, "Overview and analysis of methodologies for building ontologies," *The Knowledge Engineering Review*, vol. 17, no. 02, pp. 129–156, 2002.
- [7] M. Ferndndez, A. G.-P. rez, and N. Juristo, "Methontology: From ontological art towards ontological engineering," AAI Technical Report SS-97-06. Compilation copyright 1997, AAI ([www.aaai.org](http://www.aaai.org)). All rights reserved., 1997.
- [8] B. G, "Nine things you can do with old software." *IEEE Software*, vol. 25, no. 5, pp. 93–94, September 2008.
- [9] A. Gangemi, G. Steve, and F. Giacomelli, "Onions: An ontological methodology for taxonomic knowledge integration," in *ECAI-96 Workshop on Ontological Engineering*, 1996.
- [10] M. Grninger and M. S. Fox, "Methodology for the design and evaluation of ontologies," 1995.
- [11] J. Holden, J. MacDougall, and R. McGuire, "Information integration for concurrent engineering (iice) ideo5 method report," Armstrong Laboratory AL/HRGA, 1994.
- [12] D. B. Lenat and R. V. Guha, *Building Large Knowledge-Based Systems: Representation and Inference in the CYC Project*. Reading, Massachusetts: Addison-Wesley, 1990.
- [13] K. Mahesh, "Ontology development for machine translation: Ideology and methodology," 1996.

- [14] N. MARS, W. TER STAL, H. DE JONG, P. VAN DER VET, and P.-H. SPEEL, "Semi-automatic knowledge acquisition in plinius: An engineering approach," in Proc. 8th Banff Knowledge Acquisition for Knowledge-based Systems Workshop, Banf, ser. 4.1-4.15, January 30th-February 4th 1994.
- [15] A. D. Nicola, M. Missikoff, and R. Navigli, "A proposal for a unified process for ontology building: Upon," in In Proceedings of 16th International Conference on Database and Expert Systems Applications (DEXA, 2005.
- [16] N. F. Noy and D. L. McGuinness, "Ontology development 101: A guide to creating your first ontology," Stanford University, 2001.
- [17] C. Partridge, Business Objects: Re-Engineering for Re-Use [2nd Edition]. BORO Centre, 2005, no. ISBN 0-9550603-0-3.
- [18] R. Patil, K. Knight, and T. Russ, "Towards distributed use of large-scale ontologies," in In AAAI Spring Symposium on Ontological Engineering, 1997.
- [19] B. Smith, "Ontology," The Blackwell guide to the philosophy of computing and information, pp. 153–166, 2003.
- [20] Y. Sure, S. Staab, R. Studer, and O. Gmbh, "On-to-knowledge methodology (otkm)," in Handbook on Ontologies, International Handbooks on Information Systems. Springer, 2003, pp. 117–132.
- [21] M. Uschold and M. King, "Towards a methodology for building ontologies," in In Workshop on Basic Ontological Issues in Knowledge Sharing, held in conjunction with IJCAI-95, 1995.
- [22] I. W. S. WICAKSANA, "Survei dan evaluasi metode pengembangan ontology," in Komputer dan Sistem Inteligen (KOMMIT 2004), Agustus 2004.

# **ENGINEERING APPLICATION**

# Design of Portable Digester for Domestic and Restaurant Organic Solid Waste Processing as Clean Biogas In Replacing LPG as Alternative Energy Source

**Agus Mansur, Agus Taufik, Dian Janari**

Industrial Engineering Department, Faculty of Industrial Technology  
Universitas Islam Indonesia  
e-mail: gus\_mansur@uii.ac.id,kerjadian@gmail.com

## ***Abstract***

*Fuel consumption that reaches 1,3 millions/barrel is unbalance with production that only reaches 1 million/barrel. Its shortage, hence, has to be fulfilled by importing. This research is designated to apply biogas technology in the form of applicative Portable Digester, suitable for public under good quality, reasonable price and applicable in limited area. Based on the research, the selected designs for Portable Digester to be assessed using Scoring concept are: (a) design concept 2 that will later be applied as design A; (b) design concept 3 that will later be applied as design B; (c) design concept 5 that will later be applied as design C. The selected design concept is the concept B with score of 1,98.*

**Keywords :** *biogas, digester, portable digester*

## **1 INTRODUCTION**

The raise of worlds oil price provides huge effects to Indonesian development. Fuel consumption that reaches 1,3 millions/barrel is unbalance with production that only reaches 1 million/barrel. Its shortage, hence, has to be fulfilled by importing. According to 2006 data issued by ESDM, Indonesian oil reserves only 9 billion barrel remain. Excessive oil use will cause terrible consequences to earth, for instance global warming. It elevates within 1% raise every year and continues raising (Qasim 1994). For the last decades, alternative energy source that can be employed as the replacement of petroleum fuel are biofuel and biogas that using sustainable organic material or degradation process. Biogas is a gas that produces micro-biologically from anaerobic organic waste (Khorsidi and Arikan, 2008). Biogas consists of methane CH<sub>4</sub> (55-70%), CO<sub>2</sub> (25-50%), H<sub>2</sub>O (1-5%), H<sub>2</sub>S (0-0,5%), N<sub>2</sub> (0-5%) and NH<sub>3</sub>(0-0,05%) (Deublein dan Steinhauser, 2008). Entire biological process can be classified into four consecutive reactions, which are: hydrolysis (liquefaction), acidogenesis, acetogenesis and methanogenesis.

Anaerobic digestion process that is designated to produce biogas of organic matters is influenced by several factors, which are: (1) fermented substrate that is a better substrate

(Winarno, 1992); (2) anaerobe fermentation process is sensitive to temperature changes (Wellinger and Lindeberg, 1999), hence the increasing of temperature can enhance the production of biogas (Metcalf dan Eddy 2003; NAS 1981; Bitton 1999; Wllinger 1999); (3) Neutral pH ranged between 6,6 7,6 is the best pH to be used in anaerobe decomposition process (Ikbal et al 2003; Kadarwati 2003; Reith et al. 2002); (4) Volatile Solids (VS) are the food for hydrolysis process as well as acid formation anaerobically (Karki et al. 1994); (5) Total Solid is the solids that measured based on its remaining quantity (mg/l) on heating temperature between 103-105 C (Isa.etal.,1980); (6) hydraulic retention time (HRT) is the duration of substrate in reactor before flowing out as effluent (Kida et al. 1990)

Biogas process of organic matters that conducted by selecting wastes is reluctant to be performed by Indonesian people. Narrow area also emerged as other potential problems. Hence, the digester unit that produces biogas is created. It uses for cooking by using SOP for domestic scale. It turns to be an effective solution to bridge Indonesias two main problems. This unit later called as Portable Digester. This research is purposed to implement the biogas technology in the form of applicative Portable digester unit, under good quality, reasonable price and able to be installed on limited area. A business unit with capability of designing and producing the Portable Digester is expected as the result of the research. Therefore, it can be distributed to public with competitive cost. This designated to assist society to fulfill their needs on energy yet reducing the burden of governments subsidy cost on energy and waste management.

## **2 RESEARCH METHODOLOGY**

### **2.1 Data Collecting**

Data collecting is conducted under certain ways:

1. Interviewing the waste managements experts by proposing general questions in order to observe the biofuel process
2. Literature study, to be familiar with theories and basic concepts that related to product design and sources of references to formulate basic theories that later will be used as a basic of the research
3. Questionnaire distribution to assess the alternative designs as a filtering process and concept assessment.

### **2.2 Design Process**

This process actively involves stakeholders that highly related to biogas process. Active participation on the designing process involves experts on biofuel, community of waste management and users. First stage consists of several steps. First step is team selection that consists of 1 person from mechanical engineering background, 1 person from waste management field, and another person as a representative of waste management community. Second step is designing Portable Digester with various alternatives by conducting routine discussion based on classification tree that already approved by other team members. Third step is conducting evaluations toward several design alternatives.

## 2.3 Design Selection

On this stage, Portable Digester unit design selection is performed out of several purposed alternatives under specific steps as follows: (1) Gathering all team members and explaining the method to fulfill the questionnaire; (2) Fulfilling the questionnaire conducted by team members; (3) Processing the questionnaire that will be later used to assess the alternatives of designs. The design that reaches highest score will be the selected design. It will be later designed as expected by waste management community on how a portable digester should be.

## 2.4 Raw Material and Tools in Making Portable Digester

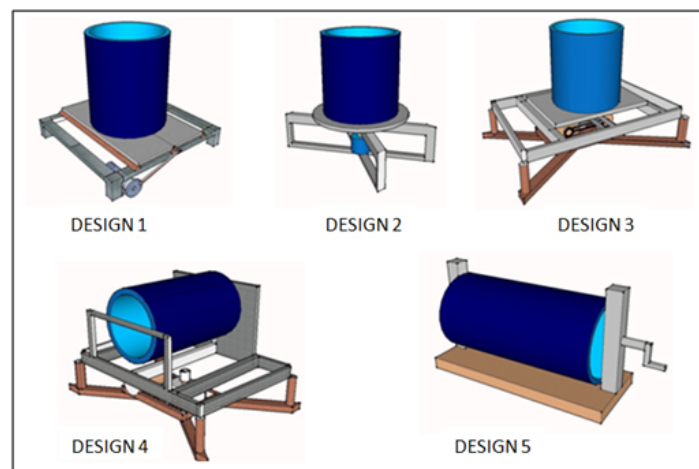

Figure 1: Designs of Portable Digester

Raw material and tools that will be employed are: (1) elbow plate 50x50x4 that is used as main frames supporting; (2) cutting grinding disc that is used to cut elbow plate; (3) Steel plate and axle are used to cover the main frame; (4) Bearing UFC and buckshot 30 mm for upper drum rotating axle; (5) Plastic drum with 220 liter capacity that used to hold the liquid of biofuel former; (6) elbow plate (40x40x4) 4 m for supporting upper drum; (7) bolt nut 14 mm to lock upper drum rotation; (8) trellis plate 4 mm to reinforce side main frame; (9) Bearing 6204 for drum rotating ball; (10) Steel pipe 5 inch to support additional main frame; (11) Various of glues and Shock pipes to flow the liquid inside or outside; (12) Various pipes and faucets for the flows; (13) Epoxy and putty for painting supporting; (14) Spray gun for painting spraying; (15) Thinner to dilute the paints

## 3 RESULT AND DISCUSSION

### 3.1 Need Identification of Waste Management Community

Portable Digester is designed based on communitys need as follows:(1)compact design (2)using available material (3)safe (4)reasonable production cost (5)good safety system (6)con- cise biogas process (7)Flexible usage (8)good durability and strong (9) considerably cheap.

Table 1: Design Concept Filtration of Portable Digester

Selection Criteria	Alternative Design Concept				
	Portable	Portable	Portable	Portable	Portable
	Digester 1	Digester 2	Digester 3	Digester 4	Digester 5
Compact Production	+	0	+	-	+
Easyto produced	-	+	-	-	+
Cheap Material	0	-	+	+	0
Appropriate extents	+	+	+	0	0
Easy to use	+	+	+	+	+
Easy to fix	-	0	0	-	+
Easyto maintain	0	+	+	0	-
Low Price	-	-	+	+	+
Total +	3	3	6	3	5
Total 0	2	2	1	2	2
Total -	3	2	1	3	1
<b>Final Score</b>	<b>0</b>	<b>1</b>	<b>5</b>	<b>0</b>	<b>4</b>
<b>Level</b>	<b>4</b>	<b>3</b>	<b>1</b>	<b>4</b>	<b>2</b>
<b>Decision</b>	<b>N</b>	<b>Y</b>	<b>Y</b>	<b>N</b>	<b>Y</b>

Description :

N = NO (Design is rejected)

Y = YES (Design is accepted)

### 3.2 Filtering Identification of Design Concept

The considerations on Portable Digester designing are the shape, materials and biogas process capacity. Based on the concept classification tree and interviews with community and experts of waste management, hence, five alternative concepts of Portable Digester are proposed. They are shown on below figure 1:

According to above five alternative designs, design filtering concept is then conducted. This filtering is based on society and designers assessment. The result of filtering concept is shown on table 1:

From the results shown by table 1, it can be concluded that:

1. Design concept 2 is accepted; therefore, it converted to be design A and later assessed using scoring concept.
2. Design concept 3 is accepted; therefore, it converted to be design B and later assessed using scoring concept.
3. Design concept 5 is accepted; therefore, it converted to be design C and later assessed using scoring concept.

Later, the concept design will be converted to A, B and C as illustrated by figure 2



Design Concept and Specification	
	<p>Concept A:</p> <ol style="list-style-type: none"> <li>1. Casting frame with solid gray</li> <li>2. Prime system is electric motor</li> <li>3. 360 rotation on di pedestal axle</li> <li>4. Direct Mover</li> <li>5. Drum capacity of 220 liter</li> <li>6. Drum Pedestal of casting plate</li> <li>7. Supported solid construction</li> </ol>
	<p>Concept B:</p> <ol style="list-style-type: none"> <li>1. L Plate frame</li> <li>2. Prime system is OEM electric motor</li> <li>3. Supported Oval Rotation</li> <li>4. UFC 1/50 mover</li> <li>5. Drum capacity of 220 liter</li> <li>6. Flat plate drum pedestal 5 mm Knock down construction</li> </ol>
	<p>Concept C:</p> <ol style="list-style-type: none"> <li>1. Square plate frame</li> <li>2. Manual system</li> <li>3. 360 rotation on pedestal axle</li> <li>4. Direct mover</li> <li>5. Drum capacity of 220 liter</li> <li>6. Solid wood drum pedestal Supported solid construction</li> </ol>

Figure 2: Concept design will be converted to A, B and C

### 3.3 Selected Portable Digester Design

Table 2 shows the result of filtering and concept assessment using scoring method, while, selected design is shown on figure 3.

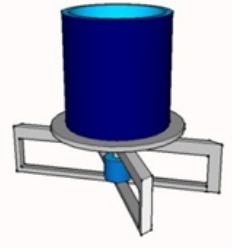
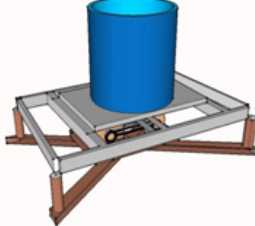
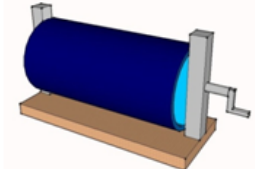
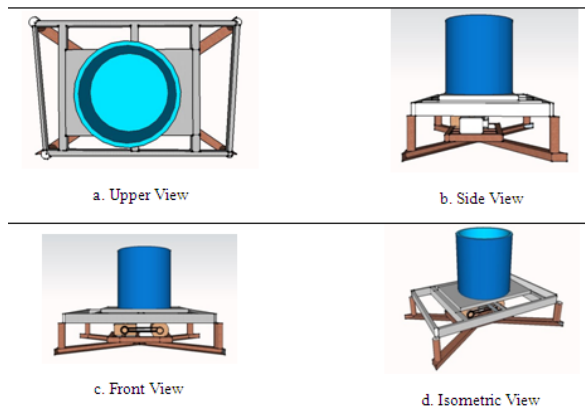

Figure 3: Design of Selected Portable Digester

The selected Portable Digester design is concept B with score of 1,98.

## 4 CONCLUSION

Based on the research, the selected designs for Portable Digester to be assessed using Scoring concept are: (a) design concept 2 that will later be applied as design A; (b) design concept 3 that will later be applied as design B; (c) design concept 5 that will later be applied as design C. The selected design concept is the concept B with score of 1,98. The design specifications of portable digester are as follows: (1) Frame of digester is using L plate; (2) prime system is using electric motor OEM; (3) rotating drum table is using oval that supported by UCF; (4) the table pedestal is using UCF 1/50; (5) drum capacity is 220 liters; (6) drum plate pedestal is 5 mm; (7) Whole construction is knock down system.

## References

- Bitton, G. (1999). *Wastewater Microbiology*. 2nd ed. Wiley Liss Inc. New York
- Deublein, D. and Steinhauser, A. (2008). *Biogas from Waste and Renewable Resource*, Wiley-VCH Verlag GmbH & Co. KGaA, Weinheim.
- Ikbal, Tang, Y., Fujimura, Y., Shigematsu, T., Morimura, S., and Kida, K. (2003). *The affecting factors for optimization of mesophilic aceticlastic methanogenesis*. J. Water Treatment Biology, 39, 189- 197
- Isa, Z., Yong, W. M and Singh, M. M. (1980). *Manual of Laboratory Methodes for Chemical Analysis of Rubber Effluent*. Kuala Lumpur, Rubber Research Institute of Malaysia.
- Kadarwati, Sri, (2003). *Studi Pembuatan Biogas dari Kotoran Kuda dan Sampah Organik Skala Laboratorium*. Publikasi P3TEK Vol. 2, No.1
- Karki, A. B., Gautam, K. M. and Karki, A. (1994). Biogas for Sustainable Development in Nepal. *Second International Conference on Science and Technology for Poverty Alleviation*, organized by Royal Nepal Academy for Science and Technology (RONAST), Kathmandu, Nepal.
- Khorshidi, N. and Arian, B. (2008). *Thesis, Experimental Practice in order to Increasing Efficiency of Biogas Production by Treating Digestate of Sludge*, University College of Boras School of Engineering
- Kida, K., Morimura, S., Sonoda, Y., Obe M., and Kondo, T. (1990). *Support media for microbial adhesion in an anaerobic fluidized-bed reactor*. J. Ferment. Bioeng. 69, 354-359
- Metcalf, Eddy Inc., (1991). *Wastewater Engineering Treatment, Disposal, Reuse* (3rd Ed). McGraw-Hill International Edition
- National Academy of Sciences (NAS) (1981). *Methane generation from human, animal, and agricultural wastes*. Second edition. National Academy of Sciences, Washington, D.C. 131p.
- Wellinger A, A. Lindeberg (1999). *Biogas upgrading and utilization*. IEA Bioenergy Task 24: energy from biological conversion of organic wastes
- Winarno, F.G., (1992). *Kimia Pangan dan Nutrisi*. Penerbit PT Gramedia Jakarta

## Clustering Analysis for Tourism Research: Segmentation Based On Travelers Activities

Imam Djati Widodo, Harwati, Agus Mansur

Universitas Islam Indonesia

e-mail: imamdjati@uii.ac.id, harwati@uii.ac.id, harwati@uii.ac.id

### **Abstract**

*Yogyakarta is one of the most promising tourism destinations in Indonesia. This is because Yogyakarta has many supporting aspects as potential natural beauty: the area is rich in ancient sites, and cultural attraction. The purpose of this study is to classify tourists by tourism activities in the area of Yogyakarta. Industry market segmentation in Yogyakarta tourism is expected to provide a description of the type of tourists visiting Yogyakarta as a basis for drafting the products and services in accordance with the wishes of tourist travelers. The result of the analysis shows that there are for cluster of tourism in Yogyakarta, they are: established travelers (19%), group travelers (35%), regular travelers (22%) and frugal travelers (24%). Biggest tourist cluster is the group of tourists with typical students, come in large numbers and spending money in small amounts during in Yogyakarta.*

**Keywords :** *Tourism, Clustering, Yogyakarta, Segmentation, K-mean, Activities*

### **1 INTRODUCTION**

Tourism is an industry that is experiencing rapid growth worldwide and has gradually changed from a secondary requirement (luxuries) to a primary requirement (basic needs) which means that at a certain period a person must be able to carry out tourism activities (Putra, 2008). The growth of a particular industry sector would require a sufficiently specific strategy concept on how the services supplied tourist products to offset the desire of the consumer as a connoisseur product. Similarly, the industrial sector in the Special Region of Yogyakarta (DIY). DIY is one of the tourist destinations both locally and overseas beside of Bali, Bandung, Lombok, etc. The arrival of tourists each year continues to increase as shown in Figure 1.

Yogyakarta is one of the most promising tourism destinations in Indonesia. This is because Yogyakarta has many aspects that support them as potential natural beauty, the area is rich in ancient sites, and cultural distinctiveness. Besides, Yogyakarta also has a lot of souvenirs and handicrafts such as batik, silver and pottery with competitive quality. With these forces Yogyakarta has a chance to become one of the important tourist destinations, at the national, regional, and international levels. With a fairly large tourism potential, should be able to attract tourists Yogyakarta greater.

Has done a lot of business and marketing strategies for the attractions in the province, however the marketing effort is still not optimal (Wicaksono, 2013). Refocusing is necessary so that the effectiveness of the marketing strategy could be better (Nuryanti, 2010). To optimize the marketing of the city of Yogyakarta as a tourism product need further study on the characteristics of consumers, which in this case tourists who visit, so in the end the manager of tourism activities, both government and private sector can provide details of all requests related to Yogyakarta tourism activities.



Figure 1: Graph Arrivals DIY 2005-2011 (Source: BPS)

Activities to understand consumers more deeply are also called market segmentation, namely the division of the market into different groups based on the needs, desires, behavior or tastes for different products or services (Day in Onalapo, 2011). Market segmentation in Yogyakarta tourism industry is expected to provide a description of the type of tourists visiting Yogyakarta as a basis for drafting the tourism products and services in accordance with the desire of tourists.

## 2 RESEARCH METHODOLOGY

### 2.1 Research Purpose

The purpose of this study is to tourists grouping tourist based on activities in the area of Yogyakarta. The results will be obtained through this study can be utilized various stakeholders such as local government, other institutions as a basis for consideration in decision making in the management of the tourism industry in DIY.

### 2.2 Research Method

Some research on the analysis of the tourism industry have been done before from various aspects. Marcel Meler, Dragan Magas, and Duro Horvat (2011) reviewed the literature on tourism industry groupings based group of small and medium industries in the Republic of Croatia. This study concluded that the development of the tourism industry in the Republic of Croatia which is based on the development of small industries is very feasible. This is because small industry is on of the important segment in the development of the national economy. Grouping can be based on several things such as tourist attractions, transportation advice, shopping, hotels, restaurants and so that all of these aspects can be developed into a kind of small industries that benefit society. Chul-Min Mo, Mark E Havitz, and Dennis R

Howard (1994) conducted a study to classify tourists according to a scale that is contained in the International Tourism Role (ITR). The results showed that of the 461 respondents can be grouped into four main clusters based on the socio demographic and travel behavior of tourists. Four clusters are groups of adventurous travelers, tourists who like a new tourist destination, tourist groups who want the convenience and the last group of tourists who like social contact with the environment.

A few years after that, clustering method is also used to classify tourists in the UK. Alzua, et al (1998) classify tourists according to several variables include demographic, travel characteristics, goals and objectives visited most likely to visit, activities involved, tourist philosophy, benefits sought, and habits during the tour. The results showed that there are five groups of tourists were formed, namely cluster teenagers traveled with backpackers, tourists cluster medium families with destination public places, family tourist cluster of old age, with a medium-sized tourist cluster specific tourist destination, and tourists who visit the family clusters.

More specifically Hsueh and Tseng (2012) examines the tourist cluster based on the type of accommodation that is used in the city of Cing Jing Taiwan. The results showed that the factors that influence tourists in choosing among others tranquility accommodation facilities, accessibility, location, and the scenery around the site. Tourist clusters are formed among other tourists who prefer to live in the mountains more than tourists who choose to live in urban areas.

Tourist clusters can also be the first step to develop the tourism potential of a region or country. As found in research Barahi, et al (2011) in the country of Nepal. Tourist cluster aimed at providing a strong foundation for the development of tourism potential in Nepal as one of the poorest countries in the world.

This study is part of a series of studies to develop the concept of Yogyakarta as a tourism city. The grand design of this study is to design the concept of Yogyakarta as a city tour includes a study to analyze public perceptions of tourist arrivals, tourist mapping studies, research to identify potential and tourist facilities and so forth. In this study will be carried out various activities to be able to classify tourists by tourism activities are carried out. Cluster analysis is done to classify tourists by tourism activities undertaken. This is done to determine the segmentation of tourists as consumers of attractions in Yogyakarta so that profiling in industrial policies related to tourism in Yogyakarta will run well.

### **3 RESULT AND DISCUSSION**

#### **3.1 Profile of Respondent**

Collecting data in this study is done through the deployment of 250 questionnaires in several tourist destinations in Yogyakarta. Traveler profiles collected are as follow:

#### **3.2 Tourism Cluster**

The next calculation is to Yogyakarta traveler grouping based on the profile and the activities conducted. Grouping is done with non-hierarchical clustering method using k-means cluster algorithm with the number of clusters (k) is determined at the beginning of four clusters. Variables used in the clustering process as many as ten (10) variables, namely:

1. Origin Travelers

Table 1: Profile of the Respondent

Nu	Variabel	Result of the Survey
1	Gender	Man: 56.2% Women: 43.2%
	Age	15-20 years old: 35.2% >20-30 years old: 54.4% >30-40 years old: 6% >40-50 years old: 2.8% > 50 years old: 1.6%
2	Origin	Midle Java: 37.6% West Java and Jakarta: 24.8% East Java: 14% Outside Java: 19.2% Etc: 4.4%
3	Occupation	Student: 58.8% Civil Staff: 17.2% Trader: 1.2% Bussinessman: 12.8% Etc: 10%
4	Income per month	0mil -5mil: 81.6% >5mil -10mil: 12% >10mil -15mil: 2.8% >15mil 20mil: 2.4% > 20 mil: 1.2%
5	Frequency per year	Once: 10.8% Twice: 14.8% Three times: 8.4% Four times: 10.8% Etc : 55.2%
6	Duration of Vacation	< 3 days: 59.2% 1 Week: 25.2% 2 Weeks: 2.8% 1 Month: 2.4% ≥ 1 month: 10.4%
7	Community in Vacation	Alone: 8.8% Friends: 50% Family: 31.5% Group: 4% Etc: 5.6%
8	Budget	< 2 mil: 62.8% 2 <3mil: 18.4% 3 - 4 mil: 8.8% 4 5 mil: 3.6% > 5 mil: 6.4%
9	Accomodation	Family: 38.4% Star Hotel: 14% Cheap Hotel: 11.6% Homestay: 12.4% Etc: 23.6%
10	Transportation	Private Car: 46.4% Rent Car: 22% Taxi: 9.2% Public Transport: 13.6% Etc: 8.8%
11	Fovourite Destination	Natural: 34.4% Shopping: 26.4% Food: 9.05% Local People: 6.8%

2. Work Travelers
3. Revenue Travelers
4. Frequency
5. Duration Travelers
6. Accomodation
7. Transportation Travelers
8. Budget Travelers
9. Interest Travelers
10. Community on Vacation

From the initial output of SPSS 16 above can be concluded that the data used for the formation of clusters is valid then later clustering process is done. By using the k-means cluster algorithm obtained results are presented in the following figure 2:

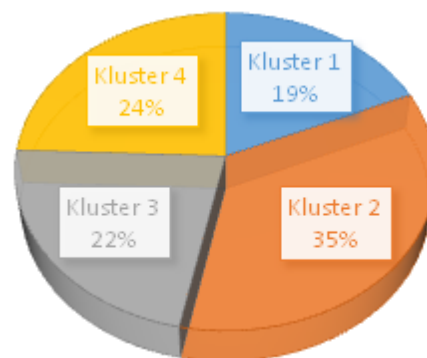

Figure 2: Result of Clustering

Respondents were used as input in this research is the data tourists who come to Yogyakarta with a variable that is used as a criterion pengkluster consists of origin of tourists, tourists job, tourist income, frequency of visits, length of tourist visits, lodging, transportation of tourists, budget travelers, tourist attraction , and tourist communities. Respondents were then grouped based on existing criteria. The amount of data used is 250 data.

At this early stage in the method of "K-Means Cluster" begins by determining in advance the number of desired clusters. In this study used cluster number is 4 cluster. Based on the ten criteria used, traveler profiles formed four major groups as follows:

1. Cluster 1. Consists of 46 respondents or 19% of the total respondents. In this group contains most of the tourists who come from areas outside of Java that works as a self-employed with incomes between 5-10 million per month. In a year, this cluster could visit Yogyakarta three times with an average spend a week during in Yogyakarta.

The visit is usually done with the family and spend 3-4 million dollars for a visit, stay in hotels and using charter transportation to visit another area of the area of unity mainly to natural attractions. Viewing of profiles generated clusters, cluster "established tourists" is the right name to describe the characteristics of the tourist group.

2. Cluster 2. Consists of 87 respondents or 35% of the total respondents. In this group contains most of the tourists who come from Central Java and West Java are still a student or students. Income below 5 million per month. The frequency of visits could not be determined. However, in a single visit can spend 3 days to 1 week. Most stay in the middle class and visited attraction in the form of natural attractions and shopping. The tourist group was also staying at the hotel and using charter transportation to visit unity area to another. Viewing of profiles generated clusters, clusters of "tourist group" is the right name to describe the characteristics of the tourist group.
3. Cluster 3. Consists of 55 respondents or 22% of the total respondents. In this group contains most of the tourists who come from Central Java and West Java who work as employees with incomes between approximately 5 million per month. Within a year of this cluster group average visit Yogyakarta by more than three times the average spend a week during in Yogyakarta. The visit is usually done with the family and spend 2-3 million dollars during the visit, the usual hotel stays and using charter transportation to visit the entire attractions object in Yogyakarta, such as nature tourism, shopping tourism, cultural tourism, etc. Viewing of profiles generated clusters, cluster "ordinary tourists" is the right name to describe the characteristics of the tourist group.
4. Consists of 61 responden or 24% of the total respondents. In this group contains most of the tourists who come from the Central Java and East Java who work as employees with incomes between under 5 million per month. In a year, this cluster can only visit Yogyakarta Once-twice with an average spend between three days to a week for at Yogyakarta. The visit is usually done alone or together and spend 1-2 million dollars for a visit, stay in your home or hotel class jasmine and using charter transportation to visit another area of the area of unity especially to attractions shopping. Viewing of profiles generated clusters, cluster "frugal traveler" is the right name to describe the characteristics of the tourist group.

Furthermore it can be seen that there is a unique character that appears in each cluster after profiling.

- That is: Travelers who come from outside the island of Java, it turns more included in the established tourist groups who spend a lot of money to travel in Yogyakarta.
- Travelers group mostly from areas in Central Java and West Java. This group came role in large quantities, but only spend a little money for in Yogyakarta.
- Natural and shopping object shopping is visited by almost all groups / clusters of tourists.



## 4 CONCLUSION

From the analysis of the application cluster technique in finding the characteristic pattern of tourists visiting Yogyakarta can be concluded that there are four clusters are formed based on ten criteria: established travelers (19%), group travelers (35%), regular travelers (22%) and frugal travelers (24%). Biggest tourist cluster is the group of tourists with typical students, come in large numbers and spending money in small amounts during in Yogyakarta.

## 5 ACKNOELEDGMENT

This research was supported by a grant of Directorate of Research and Community Service Universitas Islam Indonesia. The data, statement, and the view expressed are solely the responsibly of the authors.

## References

- Dinardani Ratrisari, Hadi Wahyono, (2012), Kontribusi Obyek Wisata Di Kota Yogyakarta Terhadap Pendapatan Asli Daerah (PAD), *Jurnal Tata Loka*; Volume 5; Nomor 1, Universitas Diponegoro, Semarang.
- Marcel Meler, Dragan Maga, Duro Horvat, (2011), The SMEs Role in the Tourism Industry Cluster Formation in the Republic of Croatia, *TMC Academic Journal*, 5(2): page 24-33.
- Chul-Min Mo, Mark E Havitz, dan Dennis R Howard , (1994), Segmenting Travel Markets with the International Tourism Role (ITR) Scale, *Journal of Travel Research 1994*; 33; page 24.
- Hsueh Ya-Hui Tseng, Hsiu-Yuan, (2012), Exploring the Clustering Location of Accommodation Units through the Tourism Development in the Cing Jing area of Taiwan, *International Journal of Basic & Applied Sciences IJBAS-IJENS* Vol:13 No:04
- Barahi Shraddha, Fan Rui Hung Phoebe, MallaPukar, YeungRaymond, (2011), *Tourism Cluster in Nepal Microeconomics of Competitiveness*, Harvard Bussiness School, USA.
- AlzuaAurkene,Leary T.O Joseph, Morrison M Alastair, (1998),Cultural and Heritage Tourism: Identifying niches for international Travelers, *The Journal Of Tourism Studies* Vol. 9, No. 2
- IordacheCarmen, CiochinIuliana, AsandeiMihaela, 2010, Clusters -Tourism Activity Increase Competitiveness Support, *Theoretical and Applied Economics Volume XVII (2010)*, No. 5(546), pp. 99-112
- Kartajaya, H., (1998), *Marketing Plus 2000: Siasat Memenangkan Persaingan Global*, Gramedia, Jakarta
- Kotler, P. & Amstrong, G. 91997), *Prinsip-prinsip Pemasaran*, Penerbit Erlangga, Surabaya
- Nuryanti, W., (2010), Strategi pemasaran pariwisata diy tahun 2010, <http://www.slideshare.net/EddyPurnomo/strategi-pemasaran-pariwisata-diy-prof-wiendu> (accessed 1/16/2014)

- Putra D.C Kadek, (2008), Strategi Public Relations Pariwisata Bali, *Jurnal Ilmu Komunikasi* Volume 5, Nomor 1.
- Pemerintah Republik Indonesia, (2009), *Undang-undang Pariwisata No 10 Tahun 2009*.
- Oyelade, O. J, Oladipupo, O. O, Obagbuwa, I. C, (2010), Application of k-Means Clustering algorithm for prediction of Students *Academic Performance*, *International Journal of Computer Science and Information Security*, Vol. 7
- Setiadi, N. J., (2008), *Perilaku Konsumen: Konsep dan Implikasi untuk Strategi dan penelitian Pemasaran*, Kencana, Jakarta
- Wicaksono Soni, (2013), *Pengembangan Pasar Pariwisata Jogja Masih Terbuka*, SuaraMerdeka.
- Onaolapo A. A., Salami A. O, Oyedokun A. J, (2011), Marketing Segmentation Practices and Performance of Nigerian Commerical Banks, *European Journal of Economics, Finance and Administrative Sciences* ISSN 1450-2275 Issue 29.

## Design of Ergonomics Ladle Appliance for Metal Casting Process

A. Hartomo Soewardi, B. Rizki Budhisaputra

Industrial Engineering Department  
Faculty of Industrial Technology  
Islamic University of Indonesia Yogyakarta  
e-mail: hartomo@uii.ac.id, rizkibudhisaputra@gmail.com

### *Abstract*

*The ladle appliance is a tool used to pour liquid metal into mold in the metal casting process. Two workers with use a certain posture do this process manually. This activity may cause musculoskeletal disorder at whole workers body part. It was indicated that more than 55% of worker experiencing pain in back, neck, arm and leg. Objective of the research is to propose an ergonomic design of ladle tools for reducing unnatural posture such that it can avoid musculoskeletal disorder. Rapid Entire Body Assessment method was used to identify work posture and NIOSHs lifting equation was used to determine the optimal method in pouring activity. Result of the research show that ergonomic ladle designed can reduce musculoskeletal disorder on workers body part about 29%.*

**Keywords :** *Ergonomics, Musculoskeletal Disorder, lifting equation, REBA, Ladle*

### 1 INTRODUCTION

Recently metal is one of the raw materials that are still needed in manufacturing industry. In 2013, Ansari Bukhari state that growth of metal, iron and steel industry increased by 12.74% (antaranews.com,2013). Therefore, the metal industries should conduct an improvement to adapt in the condition. CV. Sisptra Jaya Logam is company that produce raw material metal. One main activity is metal casting process that is by pouring liquid metal into mold manually. It used manual a tool that called Ladle. The tool is like spoon and made from iron. The weight of Ladle is 10 kg and after filled with liquid metal, it is becomes 40 to 60 kg. When using ladle many parts of body are at risk of musculoskeletal disorder. It is caused by unnatural posture and heavy load while working. Musculoskeletal disorder is a disease caused by repetitive activities, static activities and lacks of rest (Hagberg, 1997). Maximum pressure accepted by human muscle is about 30 to 40 Newton (Grandjen in Tayyari, 1997). Therefore, load that can be held by human must be calculated to avoid muscle overwork.

Many methods used to analyze posture. One of them is Rapid Entire Body Assessment method that effective to analyze all part of body (Budiman&setiyaningrum, 2004; McAtamney, 1993). Another method is NIOSH lifting equation. It is a measure tool to analyze manual material handling. This method is used to analyze load that can be lifted by body especially the spine (Sari, 2011; Kroemer at.al, 1994).

The purpose of this study is to redesign of ladle for casting metal that can reduce musculoskeletal disorder on workers body part.

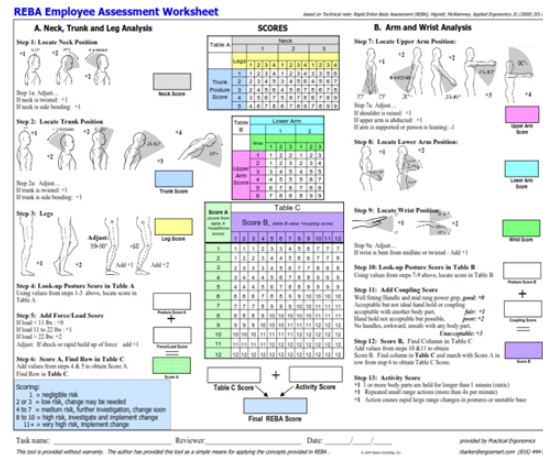

Figure 1: REBA Employee Assessment Worksheet

## 2 RESEARCH METHODOLOGY

### 2.1 Scoring Method of REBA

Scoring posture in REBA method is divided into 13 steps which is each parts has a different assessment criteria. The steps can see in figure 1.

### 2.2 Method of Recommended Weight Limit

Recommended Weight Limit trial in NIOSH’s is useful to provide the workers when safety lifting loaded. There are 7 factor variables to calculate RWL, which is (Tayyari,1997):

1. Load Constant (LC) : The LC is the maximum load that can be lifted safely, that is 23 kg
2. Horizontal Multiplier (HM). HM calculated from:

$$25/H \tag{1}$$

H : The horizontal location of the hands from the midpoint between the ankle.

3. Vertical Multiplier (VM), VM calculated from :

$$(1 - 0.003|V - 75|) \tag{2}$$

V : The vertical location of the hands from the standing floor.

4. Distance Multiplier (DM), DM calculated from :

$$(0.82 + 4.5/D) \quad (3)$$

D : The vertical distance travel between the location of the hands at the origin and the destination of the lift.

5. Asymmetry Multiplier (AM), AM calculated from :

$$(1 - 0.0032A) \quad (4)$$

A : The angular displacement of the load from the sagittal plane, measured from the origin and the destination of lift.

6. Frequency Multiplier (FM) : The average frequency rate of lifting, measured in lifts per minutes. Look at the table of Frequency Multiplier.
7. Coupling Multiplier (CM) : quality of worker's grip when lifting process. Look at the table of Coupling Multiplier.

The formula used to measure RWL is:

$$RWL = LC \times M \times VM \times DM \times FM \times AM \times CM \quad (5)$$

The formula used to measure Lifting Index is :

$$LI = \text{Lifting Load}/RWL \quad (6)$$

### 3 RESULT AND DISCUSSION

#### 3.1 Design of Ergonomic Ladle

Distance reduction of liquid metal containers adjusted to the size of the knee height so that the workers can always be in the upright position when using this tool. The width of the handle on the operator 1 also made changes since the previous tool grip is too wide so that the arm away from the body of workers in lifting process.

#### 3.2 REBA Score

REBA score in casting workstation is 8 for operator 1 and 10 for operator 2. It means that the score shows the high risk level. It is caused by use of unnatural posture while working such us squat posture and stoop posture. In ergonomics, good posture while working is when spine bent no more than 20 from the axis of the upper body, while head is not look down or look up more than 20 of the axis perpendicular to the collar bone and shoulder in a relaxed while working (Humantech,1995). After redesign, REBA scores obtained 3 for operator 1 and 4 for operator 2. That means there is a decrease in the risk of worker's posture.

REBA score obtained in smelting workstation is 10 for both of operator. That score included in the high risk level, this is caused the unnatural posture while working such us squat posture and stoop posture. In ergonomics, good posture while working is when spine

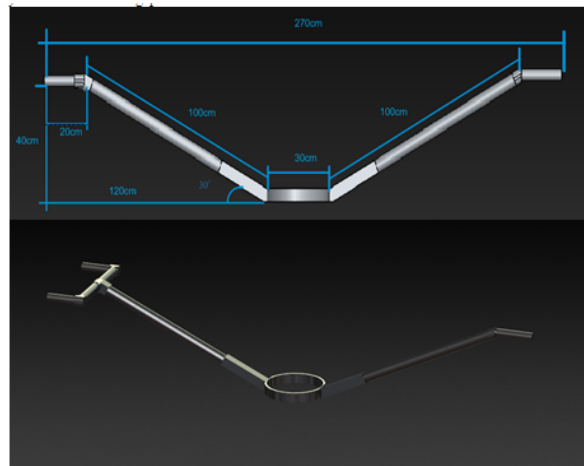

Figure 2: Design of New Ladle

Table 1: REBA Score in Casting Workstation

	Casting Workstation			
	Before		After	
	Op 1	Op 2	Op 1	Op 2
REBA Score	8	10	3	4
Action Level	3	3	1	2
Level of Risk	High	High	Low	Medium

bent no more than 20 from the axis of the upper body, while head is not look down or look up more than 20 of the axis perpendicular to the collar bone and shoulder in a relaxed while working (Humantech, 1995). After redesign, REBA scores obtained 3 for operator 1 and 4 for operator 2. That means there is a decrease in the risk of worker's posture.

### 3.3 Recommended Weight Limit

Load received by the operator 1 is 30.9 kg and operator 2 is 29 kg. All of RWL in both of workstation under load lifted workers with the result lifting index value greater than 1. The lifting task greater than 1 present a risk of musculoskeletal disorder (Tayyari,1997).

## 4 CONCLUSION

Based on the research, it can be concluded :

1. New ladle designed can reduce musculoskeletal disorder on workers body part about 29%.
2. Recommendation load of new design is 18.5kg for each worker.

Table 2: REBA Score in Smelting Workstation

	Smelting Workstation			
	Before		After	
	Op 1	Op 2	Op 1	Op 2
REBA Score	10	10	3	4
Action Level	3	3	1	2
Level of Risk	High	High	Low	Medium

Table 3: Value of Recommended Weight Limit and Lifting Index

Smelting Workstation	Before	Op 1	RWL	LI
			Op 2	11,36kg
Casting Workstation	Before	Op 1	10,9kg	2,83
		Op 2	10,4kg	2,78
	After	Op 1	18,5kg	1,24
		Op 2	20,3kg	1,13

## References

- Budiman, Edi., (2006), *Perbandingan Metode - Metode Biomekanika Untuk Menganalisis Postur Pada Aktivitas Manual Material Handling*. Purwokerto : Sekolah Tinggi Wiworotomo Purwokerto.
- Hagberg, M., Hansson-Risberg, E and Karlqvist, L. (2002), *Influence of Laptop Computer Design and Working Position on Physical Exposure Variables*. Clinical Biomechanics. Bristol : Avon
- Kroemer, K.H.E. (1994), *Ergonomics : How to Design for Ease and Efficiency*. New Jersey : Prentice-Hall Inc.
- McAtamney, L. (1993), *Handbook of Human Factor and Ergonomics Methods*.
- Prasetyowibowo, Bagas. (1999), *Desain Produk Industri*. Bandung : Yayasan Delapan Sepuluh
- Sari, Emelia. (2011), *Analisis dan Perancangan Ulang Leaf Trollys Yang Memenuhi Kaidah - Kaidah Ergonomi*. Jakarta : Universitas Trisakti
- Sastrowinoto, Suyatno. (1985), *Meningkatkan Produktivitas Dengan Ergonomi*. Jakarta : IPPM
- Tayyari, F. & Smith, J.L. (1997), *Occupational Ergonomics : Principles and Applications*. London : Chapman & Hall

## Glass Fiber Composites and Polypropylene Construction, Application for Aluminum Boat

A. Mataram, AA. Febriansyah, S. Rizal, A. Zamheri

Universitas Sriwijaya

Politeknik Negeri Sriwijaya

e-mail: agungsini@gmail.com, e-mail:aditchacha@yahoo.com,  
e-mail:arjuna68@yahoo.com, e-mail:zamherinanung@gmail.com

### *Abstract*

*Polypropylene (PP) including a type of plastic which ranks second on the most number of types of plastic waste after the type of High Density Polyethylene (HDPE). Glass fibers have superior mechanical properties of natural fibers. Because it has good mechanical properties of glass fibers currently plays an important role in the use of composite reinforcement. Aluminum has particularly lightweight and corrosion resistant properties. Of mechanical properties owned fiber glass, aluminum and PP waste can be utilized as composite reinforcement and matrix materials. This research was carried out by hand lay-up methods. Comparison of fiber volume fraction of glass, plastic and aluminum type of PP in this study are set 5x5 mm with a variation of 0% fiber glass 100% matrix, 15% fiber glass 85% matrix, 30% fiber glass 70% matrix, 45% fiber glass 55% matrix, and 60% fiber glass 40% matrix.*

**Keywords :** Composite, aluminum, fiber glass, bending test, impact test, the plastic waste

## 1 INTRODUCTION

Indonesia is a maritime country, it earned the nickname because two thirds widespread throughout Indonesia is the ocean which means more water than land. Sea separates the islands located in Indonesia, for the uniting of all we need a means of water transportation. Boat, is one of the most traditional transportation wood raw material, over time and the times, wood has more steps and expensive. Aluminum has several properties that support the transport of water to be applied.

Aluminum is a material that has the strength and the severity level of the ratio is very good compared to other materials that are often used as a material for ship construction. So also with a relatively light weight compared to other materials as the main ingredient in the construction of ships such as steel, ferro cement, wood and even though.

In real life - the results are found from the waste products that become a problem. One of them is a pile of garbage that can be one of the causes of natural disasters, flooding one.



Problems caused by the large number of plastic waste was even getting worse due to the lack of processing of the waste itself.

One of the top ranks garbage is garbage based on the amount of polypropylene plastic types. Polypropylene is a type of plastic that is often used because it has chemical resistance properties (Sahwan, 2005). One way to overcome this is by stacking bins for recycling (recycle), made of plastic waste into new materials that have added value to the function and strength of materials by adding reinforcing materials called composite materials.

Composite materials are a combination of two or more components or materials that have some characteristics that may not be owned by each of these components. The use of composite materials with the matrix and filler (filler) has become a popular type of plastic to replace metal in industry. This is due to the severity of components made of metal, which is a relatively difficult process of its formation, can experienced corrosion and high production costs.

Based on the description above, the researchers conducted a study to utilize optimally polypropylene plastic waste by making it as matrices in composites reinforced with glass fiber (fiberglass) which is then coated on metal materials, namely aluminum. With a simple processing and searching for the best volume fraction of the matrix and fibers on the mechanical properties of the resulting composites will help increase the quality, usability and protecting the environment.

## 2 EXPERIMENTAL DETAILS

### 2.1 Composite

COMPOSITE MATERIAL is a macroscopic combination of two or more different materials, can be identified with the inside of them. Composites are used not only for its structural properties, but also for electrical, temperature, tribological, and environmental applications. Modern composite materials are usually optimized to achieve a certain balance of properties required for various applications. Given the variety of materials that can be considered as composites produced and variety of uses composite materials that can be designed, composite itdak can stand alone, simple, and usability can be adjusted.

### 2.2 Classification of Composites

Composite fiber based amplifier can be categorized by chemical composition, morfologi-struktural, and commercial functions. Composites are usually classified in two different levels. The first level of classification is usually made in conjunction with the main elements of the matrix. Composite main classes including organic composites - matrix (OMCS), metal-matrix composite (MMC), and ceramic-matrix composites (CMC).

The term "organic matrix composites" are generally considered to be included in the second class composites: polymer composites - matrix (PMC) and carbon-matrix composites (often referred to as carbon-carbon composites). Carbon composites - matrix is usually formed from PMC to incorporate extra steps carbonization and original density matrix polymer. In the research and development community, intermetallic - matrix composite (be set up) is sometimes listed as a different classification of the MMC. However, the most important application of (be set up) does not exist, and in practice these materials do not provide a radical difference of nature relative to the MMC. In each of these systems, usually the entire

matrix in the continuous phase in all the components (Carl Zweben, 1998).

### 2.3 Fiber Composite Materials

The main element is a composite fiber, fiber composite material made up of fibers that are bound by a matrix of interconnected.

Fiber composite material consisting of two kinds, namely

1. long fibers (continuous fiber)
2. fiber (short fiber and whisker).

Composite materials generally use plastic because plastic is easy to come by and easy treatment, rather than metallic materials that require materials themselves.

### 2.4 Polypropylene (PP)

Several researchers have conducted studies on the use of polypropylene as a matrix in a composite of them, Research on polypropylene is also done by creating a composite with 3 types of mixtures, the first pure polypropylene matrix (without fibers), both with 30% polypropylene fiber jute, polypropylene third with 30% sisal fiber. From research obtained on the best tensile strength polypropylene fiber flax plus 30% to the value of 32.0 Mpa then polypropylene sisal plus 30% of 26.6 MPa and a final pure polypropylene its strength of 26.0 MPa (Bourmad et al, 2008).

Research using polypropylene as matrix reinforcement 2 types of fiber that pandanus fiber and banana stem fiber and polypropylene fiber pandanus formulate that has better tensile strength compared with the banana stem fiber polypropylene (Maulida, 2006).

Polypropylene has a low density compared to other types of plastic and polypropylene have a fairly high melting point (190C up to 200C), while the crystallisation point between 130oC up to 135oC. Polypropylene has a resistance to chemicals (chemical resistance) is high, but impact resistance (impact strength) is low (Mujiarto, 2005).

### 2.5 Fiber Glass

Plastic fiber glass (glass-reinforced plastic - GRP), which is also known as plastic is reinforced by glass fibers (glass fiber-reinforced plastic - GFRP), is a reinforced polymer. This polymer is made of plastic materials reinforced by fine fibers made of glass. This material is also known as GFK which is a continuation of Glasfaserverstrkter Kunststoff, or are generally more familiarly known by the glass fibers are used in the process of strengthening, which in the English language called fiberglass. GRP is a lightweight and strong material with many uses, such as in the manufacture of boats, cars, water tanks, roofing, piping, coating, motorcycle delivery box, promotional umbrella, fiberglass etc. booth. Fiberglass or glass fiber is often translated into molten glass is drawn into a thin fiber with a diameter of about 0.005 mm - 0.01 mm. These fibers can be spun into yarn or woven into fabric, which is then impregnated with a resin material so that it becomes a strong and corrosion resistant.

### 2.6 Aluminum

The ancient Greeks and Romans used alum in medicine as an astringent, and in the dyeing process. In 1761 De Morveau suggested the name "alumine" for the base in alum. In 1807,

Table 1: Studied composition formula (%)

No	Polypropylene	Fiber Glass	Al
1	100	0	10 x 10 x 55 (mm)
2	85	15	10 x 10 x 55 (mm)
3	70	30	10 x 10 x 55 (mm)
4	55	45	10 x 10 x 55 (mm)
5	40	60	10 x 10 x 55 (mm)

Davy gave a proposal to name the Aluminum metal, although in the end agreed to replace it with Aluminum. The last name is the same as the name of a lot of other metallic elements that end with "ium". (Totten and MacKenzie, 2003).

## 2.7 Mechanical Properties of Materials

After producing specimens of experiments comparing the volume fraction, the composite materials usually will do some testing in between load testing, drag, tap, slide or latitude, bending, and density to determine the physical and mechanical properties of the material examined. However, in this study only focused on the characters generated by the bend test results, and test a notch. Additional measurements are required when there are changes in the system variables occur as.

### 2.7.1 Studied composition formula (%)

Relative volume of the element, the element of nature, and the process of manufacture. Experiments can be time consuming and expensive. Mechanics-based models and methods semiempiris determining composite properties so that it can be useful to predict the effect of a large number of system variables.

### 2.7.2 Impact Test

Impact testing is a test used to determine the purpose of a brittleness or ductility material (specimen) to be tested by the sudden imposition of the object to be tested statistically.

### 2.7.3 Bending Test

In this test will be used Hydraulic Universal Material Tester with JIS Z 2248 standard to determine the plastic deformation will occur at a particular angle of curvature. To determine the magnitude of the angle of curvature that can be given to a material then tested the arch.

## 3 RESEARCH METHODOLOGY

### 3.1 Flow Chart

Research methodology in the schematic below:

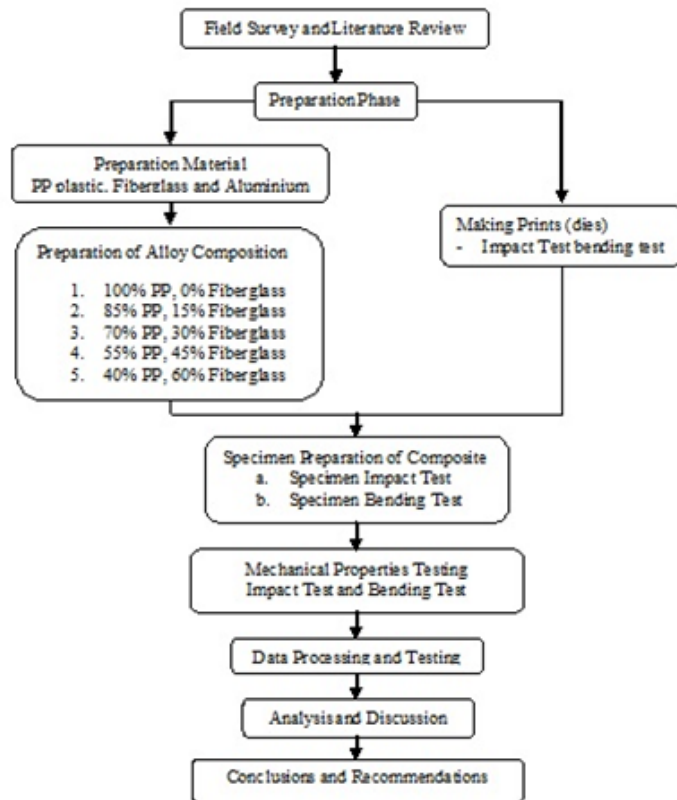

Figure 1: Research methodology

#### 4 DATA ANALYSIS AND DISCUSSION

Making plastic matrix composite materials with the former type of glass fiber reinforced polypropylene done using hand lay-up methods. Samples were prepared then testing, such as tensile testing and impact testing.

Tests performed on each - each different sample variation of the volume fraction, namely:

1. 0% = Matrix 100% with 0% reinforcement aluminum reinforcement as much as 3 specimens
2. Matrix 15% = 85% to 15% of reinforcing aluminum reinforcement as much as 3 specimens
3. Matrix 30% = 70% to 30% of reinforcing aluminum reinforcement as much as 3 specimens
4. Matrix 45% = 55% to 45% of reinforcing aluminum reinforcement as much as 3 specimens
5. Matrix 60% = 40% to 60% of reinforcing aluminum reinforcement as much as 3 specimens

#### 4.1 Impact test

From the impact test data obtained, and then viewed in graphical form, as follows :

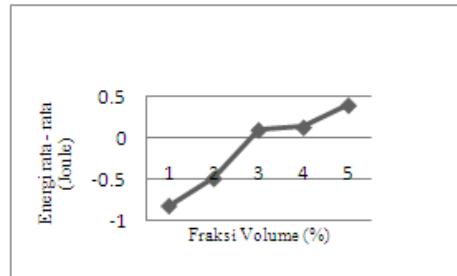

Graph showing the relationship between energy Impact (E) average - average volume fraction of the variation in the ratio

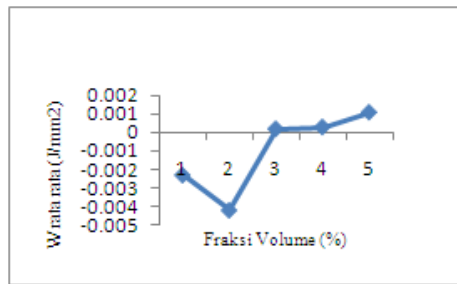

#### 4.2 Bending Test

Based on the test results and test data processing bending plastic matrix composite materials with the former type of glass fiber reinforced polypropylene obtained average value of the voltage - the highest average obtained from the variation of the matrix volume fraction 60% to 40% in the amount of reinforcement kgf/mm<sup>2</sup> 0.956, while the average value of the voltage - lowest average obtained from the variation of the matrix volume fraction of 100% with 0% reinforcement is equal to 0 kgf/mm<sup>2</sup>.

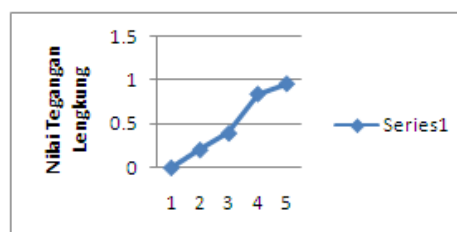

## 5 CONCLUSIONS AND RECOMMENDATIONS

### 5.1 Conclusion

Based on the research that has been conducted on composite materials bermatriks glass fiber reinforced plastic waste by hand lay-up method, it can be deduced as follows:

1. The more the percentage of glass fibers, the resulting mechanical properties, the better.
2. The optimum conditions obtained in this study is the comparison of the variation occurs in 40% volume fraction of matrix types of polypropylene plastic waste with 60% glass fiber reinforcement.

### 5.2 Advice

This study was conducted only on the volume fraction of 0% to 60% then for further research is recommended to increase the glass fiber volume fraction above 60% in the composite mixture to find a limit on the effect of raising the value of mechanical fiber composite. Further testing is also recommended for the temperature difference to get the best temperature in the recycling of waste polypropylene.

## References

- Ashby, Michael F, (2005), *Materials Selection In Mechanical Design*, Third Edition, Burlington
- ASM Handbook International, *The Materials Information Company*, Volume 4 of the ASM Handbook Heat Treating was launched in Detroit (1991).
- ASM International Handbook Committee, (2001), *Composites*, Volume 21.
- Bakri, (2011), Tinjauan Aplikasi Serat Sabut Kelapa Sebagai Penguat Material Komposit, *Jurnal Mekanikal* Vol 2 No 1 : Januari 2011 : 10 15, Jurusan Teknik Mesin, Fakultas Teknik Universitas Tadulako, Palu.
- Bhaskar, Pal, dan Haseebuddin, (2012), Analytical Estimation of Elastic Properties of Polypropylene Fiber Matrix Composite by Finite Element Analysis, *Scientific Research, Mechanical Engineering Department, Dayananda Sagar Academy of Technology and Management*, Bangalore, India.
- Bormand Alain, Christophe Baley,(2009), *Rigidity Analysis Of Polypropylene / Vegetal Fibre Composites After Recycling*, Polymer Degradation and Stability 94, 297-305.
- Chandra, R.M Dimas A, (2011), *Studi Eksperimental Pengaruh Penambahan Cacahan Limbah Polythylene Terephthalate Terhadap Kekuatan Hollow Core Slab In Situ Nonprategang*, Program Studi Teknik Sipil Fakultas Teknik Universitas Indonesia
- Darmanto, Seno, (2010), Analisa Perlakuan Silane Untuk Meningkatkan Kualitas Serat Pelepah Kelapa, *Teknis* Vol 5 No. 3 December 2010 : 112 116 Program Diploma III Teknik Mesin Universitas Diponegoro, Semarang.

- Dewi, Sinta Kristi, Yuliati, Anita dan Munadziroh, Elly, (2012), Evaluasi Perubahan Warna Resin Komposit Hybrid Setelah direndam Obat Kumur, *Jurnal PDGI* Vol 61, No. 1 Januari April 2012, Hal 5 – 9 ISSN 0024 – 9548, Departemen Material Kedokteran Gigi Fakultas Kedokteran Gigi Universitas Airlangga.
- Ginting, M Hendra S, (2006), Pembuatan Komposit dari Karung Bekas dan Polietilena dengan Pelembut Heksan, *Jurnal Teknologi Proses* 5(2) Juli 2006 : 138 – 141 ISSN 1412 – 7814, Departemen Teknik Kimia, Fakultas Teknik Universitas Sumatera Utara, Medan.
- Kaufman, J. Gilbert, dan Rooy Elwin L, (2004), Aluminium Alloy Castings : Properties, Process and Applications, *ASM International*, USA.
- Mujiarto Imam, (2005), Sifat dan Karakteristik Material Plastik dan Bahan Aditif, *Jurnal Traksi*. Vol. 3. No. 2.
- Nasmi H S, dkk, (2011), Ketahanan Bending Komposit Hybrid Serat Batang Kelapa / Serat Gelas Dengan Matrik Urea Formaldehyde, *Jurnal Ilmiah Teknik Mesin Cakram* Vol 5 No. 1 April 2011 (91 – 97), Fakultas Teknik Universitas Mataram, Mataram.
- Ron Cobden, (1994), *Aluminium : Physical Properties, Characteristic and Alloys*, TALAT Lecture 1501, Alcan, Banbury.
- Schwartz M.M, (1984), *Composite Material Handbook*, Mc Graw-will, Singapura.
- Suharto,(1995), *Teori Bahan dan Pengaturan Teknik*, Jakarta : Rineka Cipta.

## Rapid Synthesis of Graphene Nanosheets and Its Structural Properties Study for Direct Methanol Fuel Cell

Mohamad Fahrul Radzi Hanifah, Juhana Jaafar, Madzlan  
Aziz, Ahmad Fauzi Ismail

Advanced Membrane Technology Research Centre (AMTEC)  
Faculty of Petroleum and Renewable Energy Engineering  
Universiti Teknologi Malaysia, 81310 UTM Skudai  
Johor, Malaysia  
Department of Chemistry, Faculty of Science  
Universiti Teknologi Malaysia, 81310 UTM Skudai  
Johor, Malaysia  
e-mail: agungcini@gmail.com, e-mail:aditchacha@yahoo.com,  
e-mail:juhana@petroleum.utm.my

### **Abstract**

*Platinum is frequently used as the catalyst in direct methanol fuel cell (DMFC) due to high catalytic activity compared to other catalyst. However, the practical application using platinum is still limited due to high platinum cost. Graphene is the most precious carbon-based material used as the platinum support to reduce the platinum loading which is can reduce the cost. Herein, simple and rapid synthesis of graphene nanosheets (GNs) via chemical reduction of exfoliated graphene oxide nanosheets (GO) was carried out by using sodium oxalate ( $\text{Na}_2\text{C}_2\text{O}_4$ ) as reducing agent. The comprehensive characterizations were conducted in term of structural and morphology analysis such as Raman spectrometer, high resolution transmission electron microscopy (HRTEM) and x-ray diffractometer (XRD). The number of layers of the GNs was determined by HRTEM which is almost revealed the formation of monolayer. The XRD analysis showed that the large interlayer distance of GO disappeared after reduction process due to the removal of oxygen functional groups to form GNs. Therefore, the reduction process using  $\text{Na}_2\text{C}_2\text{O}_4$  can lead to the efficient removal of the oxygen functional groups from the surface of GO to produce high quality of single layer GNs which is can be applied as the catalyst support in DMFC.*

**Keywords :** *Graphene nanosheets, chemical reduction, structural, characterization*



## 1 INTRODUCTION

Direct methanol fuel cell (DMFC) is excellent power sources has been focused intensive interest for several decades due to their high efficiency of energy-conversion, low pollutant emission, availability of methanol fuel, easy handling and distribution (G. Wu et al. 2013). However, the practical applications are still limited due to the expensive platinum catalyst which is currently the most promising anode catalysts (K. Ji et al. 2012). Therefore, many efforts have been made to overcome this problem, while reducing the use of Pt-based catalysts. One of the best strategies is to use novel support of carbon-based materials to reduce the platinum loading. A Graphene nanosheet (GNs) is a carbon-based material of two-dimensional (2D) sheet consisting of sp<sup>2</sup> hybridized carbon atom that arranged in a honeycomb lattice structure (H. J. Choi et al. 2012). Recently, it has received significant attention owing to its unique characteristics such as large surface area (K. Ji et al. 2012), strong mechanical (C. Lee et al. 2008), excellent electrical conductivity (R. F. Service 2009) and good thermal stability (A. A. Balandin 2008) making it as a promising candidate for the catalyst support in DMFC. The most typical method used to produce GNs in a large quantities with the low in cost is the chemical reduction of GO (Y. Jin et al. 2013).

Graphite powder can be used as the precursor to produce GNs through the formation of graphene oxide (GO) by oxidation reaction with concentrated acid using modified Hummers method and subsequently the chemical reduction process. Hydroxyl and epoxy groups are mostly decorated onto the basal plane of GO layers, while carboxyl and carbonyl groups are decorated at the edges (K. Satheesh and R. Jayavel 2013). Recently, the uses of green and environment-friendly reducing agents to synthesis GNs have been reported such as dipotassium hydrogen phosphate (X. Zhang et al. 2013), ascorbic acid (J. Zhang et al. 2009) and L-glutathione (T. A. Pham, J. S. Kim and Y. T. Jeong 2011). However, its feasibility still requires further evaluations due to some of its drawbacks such as high in cost, experimentally time consuming and limited applications (J. Gao et al. 2010). Sodium oxalate is cheap, effective and less hazardous in the reducing process as compared with other strong reducing agents such as hydrazine and its derivatives. Therefore, in this paper, we prepare GNs via chemical reduction of exfoliated GO by using sodium oxalate as the reducing agent, the morphology and structural properties of the prepared GNs was well investigated.

## 2 RESEARCH METHODOLOGY

### 2.1 Chemicals

Purified graphite powder was obtained from Superior Graphite Co. and all the other chemicals were analytical grade and used as received without further purification.

### 2.2 Preparation of graphene nanosheets

The GO was synthesized through the oxidation of the purified graphite powder via modified Hummers method. Three grams of  $NaNO_3$  was dissolved in 140 mL of concentrated  $H_2SO_4$  in an ice bath. Then, 15 g of  $KMnO_4$  and 3 g of graphite powder were gradually added into the mixture. The temperature was kept below  $20^\circ C$  under vigorous stirring using a mechanical stir bar for 2 hours. The temperature of the mixture was then increased and maintained at  $35^\circ C$ . The mixture was continuously stirred for another 12 hours until it turned into a brown paste. After that, 250 mL of deionized water was added into the mixture

and stirred for 30 minutes. Next, 20 mL of 35% H<sub>2</sub>O<sub>2</sub> and 800 mL of deionized water were added into the mixture. The stir was continued until the mixture color changed from brown into brilliant yellow. The mixture was filtered and washed using 1 M HCl and deionized water until the pH of the filtrate became neutral. Lastly, the mixture was dried in oven at 80°C. In typical synthesis of GNs, 200 mg of solid GO was dispersed in 200 mL of deionized water under ultra-sonication for 3 hours by using a high power ultrasonic pole at 0°C until it turned into a dark-brown GO aqueous colloid. In typical reduction process from GO to RGO, 100 mL of GO colloid was mixed with 40 mL of sodium oxalate solution in a 250 mL conical flask under vigorous stirring. The final solution was kept at ± 95°C for a period 2 hours. Then, the products were centrifuged for 20 minutes at 3000 - 4000 rpm and washed using deionized water repeatedly. Finally, the products were dried at 80°C in oven.

### 2.3 Characterization

The X-ray diffraction (XRD) patterns were taken on a high resolution x-ray diffractometer (Bruker D8 Advance) using  $Cu-K\alpha$  ( $\lambda = 1.54\text{\AA}$ ) radiation with  $2\theta$  range between 5° and 40°. The morphology of the synthesized GO and GNs were characterized by transmission electron microscopy (TEM, FEI/Philips CM12) and high-resolution transmission electron microscopy (HRTEM, FEI TECNAI G2) at acceleration voltage of 120 and 200 kV, respectively. Raman spectra were recorded from 800 to 3000 cm<sup>-1</sup> on a Renishaw 1000 confocal Raman microprobe (Renishaw instruments) using 514 nm argon ion laser.

## 3 RESULTS AND DISCUSSION

### 3.1 Morphology analysis

TEM images of the GO and GNs are shown in Fig. 1a and b, respectively. GO consists of aggregation of corroded sheets while for GNs, there is wrinkle with a decrease in thickness. The clear idea of the number of the layers could be given by the folder edges of the GNs (P. Liu et al. 2013). The HRTEM images that capture the border of GNs are shown in Fig.1c. It showed that the produced GNs has the single layer as indicated by the arrow. Therefore, we can conclude that the nanoscale structure of GNs was likely to be monolayer.

### 3.2 XRD analysis

XRD was used to identify the interlayer changes of GO and GNs. The XRD patterns of the GO and GNs are shown in Fig. 2a. A typical broad diffraction peak near 12.0° which corresponded to the (002) basal plane with d-spacing  $\sim 7.37\text{\AA}$  was observed for the GO. This is due to the existence of oxygenated functional group on the GO and also the intercalation of water molecules (Y. Jin et al. 2013). For the XRD pattern of the GNs, the intensity of the peak at 12.0° was totally disappeared after reduction process. The disappearance was accompanied by a little shift of the broad band to a higher  $2\theta$  angles at 24.6.0° (inset of XRD pattern of GNs). The band corresponded to (002) plane with d-spacing  $\sim 3.61\text{\AA}$ . This suggests that the produced GNs have better order in two-dimensional (2D) structures with the removal of oxygenated functional groups from the surface of GO.

### 3.3 Raman spectra analysis

Raman spectrometer is used to determine the structural and electronic properties of prepared GNs and GO. Fig. 2b showed the Raman spectra of the GO and GNs. The D and G bands in the spectra of the GO and GNs are corresponded to the breathing mode of point phonons of  $A_{1g}$  symmetry and the first order scattering of the  $E_{2g}$  phonons of  $sp^2$  hybrid carbon atoms respectively (P. Song et al. 2012). D and G bands are related to the defects of  $sp^2$  carbon lattice of GNs and disordered conformations (X. Zhang et al. 2014). The G band of the GO was located at  $1600\text{ cm}^{-1}$  while for GNs, it shifted to  $1598\text{ cm}^{-1}$  which is closer to the pristine graphite after the reduction. It indicates that the GO has been successfully reduced. The D band of the GNs shifted to  $1351\text{ cm}^{-1}$  from the original GO location which was at  $1352\text{ cm}^{-1}$  indicating the presences of defect and disorder of the in-plane  $sp^2$  domains in the sample. Measurement of relative disorder present in a graphitic structure can be detected through a ratio between D and G bands intensities ( $I_D/I_G$ ). The intensity ratio of the D and G bands ( $I_D/I_G$ ) increased from 0.96 (GO) to 1.02 (GNs). This is due to the formation of some new  $sp^2$  carbon lattice structures during the reduction process (X. Zhang et al. 2014). In addition, the Raman spectrum of GNs exhibited a broadened 2D band at around  $2719\text{ cm}^{-1}$  as evidence that the analyzed region presence of almost single layer of GNs.

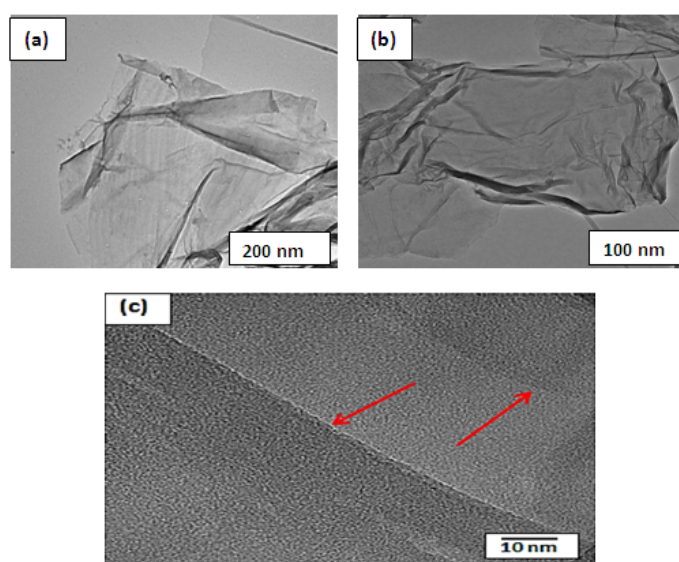

Figure 1: TEM image of (a) GO and (b) GNs, (c) HRTEM image of GNs layer

## 4 CONCLUSION

A rapid synthesis of GNs using sodium oxalate as the reducing agent has been reported. The morphology analysis of the produced GNs by the HRTEM almost revealed the formation of single layer. The XRD analysis showed that the peak of the large interlayer distance almost disappeared after reduction process due to the removal of the oxygen containing functional group. Based on the Raman spectra, the  $I_D/I_G$  ratio increased after the reduction

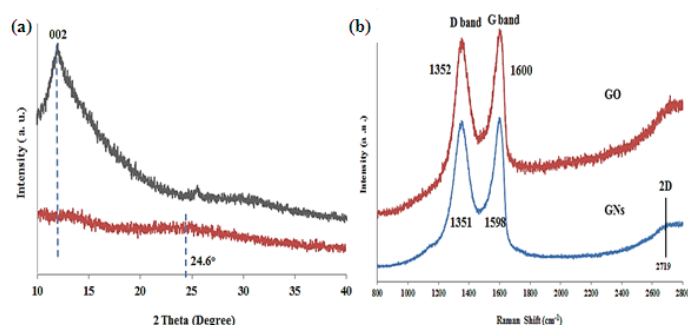

Figure 2: XRD pattern of GO and GNs (b) Raman spectra of GO and GNs

process indicating a higher degree of disorder that results in a more defective state of GO. This produced single layer of GNs could be valuable for the practical application in direct methanol fuel cell.

## 5 ACKNOWLEDGEMENT

The authors would like to express gratitude to the Ministry of Science Technology and Innovation (MOSTI) and Ministry of Education Malaysia for the research funding under Science fund Grant (Vot.R.J130000.7942.4S057) and Fundamental Research Grant Scheme (R.J130000.7809.4F592) respectively.

## References

- A. A. Balandin, S. Ghosh, W. Bao, I. Calizo, D. Teweldebrhan, F. Miao, and C. N. Lau (2008). Superior Thermal Conductivity of Single-Layer Graphene, *nano letters* 8, 902-907.
- C. Lee, X. Wei, J. W. Kysar, J. Hone (2008). Measurement of the Elastic Properties and Intrinsic Strength of Monolayer Graphene, *Science* 321 (5887): 385-388.
- G. Wu, H. Huang, X. Chen, Z. Cai, Y. Jiang, X. Chen (2013). Facile synthesis of clean Pt nanoparticles supported on reduced graphene oxide composites: Their growth mechanism and tuning of their methanol electro-catalytic oxidation property, *Electrochimica Acta* 111, 779-783.
- H. J. Choi, S. M. Jung, J. M. Seo, D. W. Chang, L. Dai, J. B. Baek (2012). Graphene for energy conversion and storage in fuel cells and supercapacitors, *Nano Energy* 1, 534-551.
- J. Gao, F. Liu, Y. Liu, N. Ma, Z. Wang, and X. Zhang (2010). Environment-Friendly Method to Produce Graphene That Employs Vitamin C and Amino Acid, *Chem. Mater.* 22, 2213-2218.
- J. Zhang, H. Yang, G. Shen, P. Cheng, J. Zhang and S. Guo (2010). Reduction of graphene oxide via L-ascorbic acid, *Chem. Commun.* 46, 1112-1114.

- K. Ji, G. Chang, M. Oyama, X. Shang, X. Liu, Y. He (2012). Efficient and clean synthesis of graphene supported platinum nanoclusters and its application in direct methanol fuel cell, *Electrochimica Acta* 85, 84-89.
- K. Satheesh, R. Jayavel, (2013). Synthesis and electrochemical properties of reduced graphene oxide via chemical reduction using thiourea as a reducing agent, *materials letters* 113, 5-8.
- P. Liu, Y. Huang, L. Wang (2013). Synthesis of reduced graphene oxide using indole as a reducing agent and preparation of reduced graphene oxide-Ag nanocomposites, *Synthetic metals* 167, 25-30.
- P. Song, X. Zhang, M. Sun, X. Cui and Y. Lin (2012). Synthesis of graphene nanosheets via oxalic acid-induced chemical reduction of exfoliated graphite oxide, *RSC Advances* 2, 11681173.
- R. F. Service, (2009). *Carbon Sheets an Atom Thick Give Rise to Graphene Dreams*, 324 (5929): 875-877.
- T. A. Pham, J. S. Kim and Y. T. Jeong (2011). One-step reduction of graphene oxide with L-glutathione, *J. Colloids Surf. A: Physicochem. Eng. Aspects* 384, 543-548.
- X. Zhang, K. Li, H. Li, J. Lu, Q. Fu, Y. Chu (2014). Graphene nanosheets synthesis via chemical reduction of graphene oxide using sodium acetate trihydrate solution, *Synthetic metals* 193, 132-138.
- X. Zhang, K. Li, H. Li, J. Lu (2013). Dipotassium hydrogen phosphate as reducing agent for the efficient reduction of graphene oxide nanosheets, *Journal of Colloid and Interface Science* 409, 1-7.
- Y. Jin, S. Huang, M. Zhang, M. Jia, D. Hu (2013). A green and efficient method to produce graphene for electrochemical capacitors from graphene oxide using sodium carbonate as a reducing agent, *Applied Surface Science* 268, 541-546.

## Antifouling Enhancement of Dual Layer Hollow Fiber Membrane By Adding $TiO_2$ Nanoparticles

Mohd Hafiz Dzarfan Othman, Hanif Mossadeq, Hazlini  
Dzinun, Ahmad Fauzi Ismail, Mohd Hafiz Puteh,  
Mukhlis A. Rahman, Juhana Jaafar

Advanced Membrane Technology Research Centre (AMTEC)  
FUniversitiTeknologi Malaysia, 81310 UTM Johor Bahru, MALAYSIA  
Faculty of Civil Engineering, UniversitiTeknologi Malaysia, 81310 UTM Johor Bahru,  
MALAYSIA

e-mail: hafiz@petroleum.utm, myhan.if91@yahoo.com, hazlini4@live.utm.my,  
afauzi@utm.my, mukhlis@petroleum.utm.my, juhana@petroleum.utm.my,  
mhafizputeh@utm.my

### **Abstract**

*Recently, titanium dioxide ( $TiO_2$ ) has been widely studied as a good antifouling material, low cost, good stability, environmental benefit, and its potential in commercial applications. Many of the pure and modified  $TiO_2$  powders, films, nanorods and nanosheets have been prepared previously for the improvement of filtration in water purification process. Polyvinylidene fluoride (PVDF) as a ferroelectric material of high ionic conductivity, good mechanical and membrane-forming properties, was known to have high chemical stability in acidic, basic, rigorous thermal and hydrolytic environment. PVDF has been combined with many different antifouling material to improve its antifouling properties. This paper reports the characterization and performance of dual layer hollow fiber with immobilized  $TiO_2$  in the outer layer membranes. In comparison, neat membrane and single hollow fiber membrane were also analyzed. The hollow fiber membranes were characterized using scanning electron microscopy (SEM), contact angle goniometer and filtration experiments. The experimental results demonstrated that dual layer hollow fiber membranes able to enhance the pure water flux and antifouling properties.*

**Keywords :** *Antifouling, PVDF, Titanium dioxide, Nanocomposite membrane*

## 1 INTRODUCTION

Membrane filtration is playing a more prominent role in the treatment of wastewater due to its advantages: no chemical additives are needed to break the pollutant, high chemical oxygen demand (COD) removal efficiencies are achieved, and treatment facilities are quite

compact and fully automated. Membrane filtration does not only facilitate the separation of suspended catalysts but also improves the effluent quality by selective separation at molecular level (Ho, Vigneswaran, & Ngo, 2009). Many studies have been done on the wastewater treatment with different membranes (Alhakimi, Studnicki, & Al-ghazali, 2003; R. A. Damodar, You, & Ou, 2010; Masuelli, Marchese, & Ochoa, 2009; Nghiem, Manis, Soldenhoff, & Schfer, 2004; Wintgens, Gallenkemper, & Melin, 2002). The selection of polymers in membrane fabrication are most important because the success of any separation system involving membrane depends on the quality and suitability of membrane incorporated in the system.

Several high performance membrane materials are found within last two decades accordingly to the advancement of membrane technology. Polyvinylidene fluoride (PVDF) has been selected as one of the most attractive polymer in membrane fabrication due to its unique properties such as excellent chemical resistance and thermal stability, high mechanical strength, its outstanding antioxidation activity, highly organic selectivity, as well as good mechanical and membrane forming properties (Ngang, Ooi, Ahmad, & Lai, 2012; Yuliwati & Ismail, 2011). In the previous study, they stated that PVDF membranes is one of membranes that possess highest stability and resistivity in comparison to other membrane types. Due to hydrophobic nature of PVDF, a number of novel strategies have been carried out on improving the PVDF membrane hydrophilicity and performance (Cruz, Semblante, Senoro, You, & Lu, 2013; Dong et al., 2012; Li, Shao, Zhou, Li, & Zhang, 2013; Madaeni, Zinadini, & Vatanpour, 2011; Rahimpour, Jahanshahi, Rajaeian, & Rahimnejad, 2011; Yan, Hong, Li, & Li, 2009).

A variety of nanoparticles have been introduced to modify organic membranes, such as  $SiO_2$ ,  $Al_2O_3$  (Yan et al., 2009),  $Mg(OH)_2$  (Dong et al., 2012) and  $TiO_2$  (Rahimpour et al., 2011; Vatanpour et al., 2012) have been extensively studied. Between them,  $TiO_2$  has acquired popularity in the hydrophilic modification of membranes because of it is superb stability, inexpensiveness, and accessibility (Razmjou et al., 2011). Moreover, it displays photocatalytic, antibacterial, self-cleaning, and ultra-hydrophilic properties upon UV irradiation (R. a Damodar, You, & Chou, 2009; Rahimpour, Jahanshahi, Mollahosseini, & Rajaeian, 2012).

Recently, many researchers have attracted to fabricate dual layer hollow fibre membrane due to its advantages such as (1) low material cost; (2) elimination of complex post treatment process; (3) optimized membrane performance by using a functional material of high performance as the selective layer. Various studies clearly reveal the applicability of dual layer fibre spinning technology for various gas (Ahmad & Ramli, 2013; Fei, Chung, Wang, & Liu, 2002; Husain, 2006; Jiang, Chung, Fei, Cao, & Kulprathipanja, 2004; Widjojo, Chung, & Kulprathipanja, 2008) and liquid separations applications (Bonyadi & Chung, 2007; Ong & Chung, 2012; Sun, Hatton, Chan, & Chung, 2012; Wang, Teoh, & Chung, 2011). Most of the researchers have focused on morphological studies and application of dual layer hollow fibre membranes as a separation medium. There is a very limited publication reported on the dual layer hollow fibre membrane structure for antifouling properties. As mentioned by Bhandari (Bhandari, Olanrewaju, Bessho, Breedveld, & Koros, 2013), the morphology of inner and outer layer of hollow fibre membrane are formed based on the required properties in each layer by manipulating of spinning parameters.

Therefore, the objective of this study is to investigate the effectiveness of  $TiO_2$  as an antifouling property in the outer layer of dual layer nanocomposite PVDF/ $TiO_2$  hollow fiber. For comparison, single layer nanocomposite PVDF/ $TiO_2$  hollow fiber that comprised the same formulation as the outer dope of dual layer hollow fibre membranes was also fabricated

and characterized. Dual layer pristine PVDF hollow fiber membranes also fabricated as a control membrane. It is expected that the dual layer hollow fiber as illustrated in Figure 1 would reduce the amount of  $TiO_2$  used and also enhance the  $TiO_2$  dispersion in the membrane.

## 2 RESEARCH METHODOLOGY

### 2.1 Preparation of Membrane

PVDF and  $TiO_2$  were dried in a  $50^\circ$  vacuum oven for 24 hour to remove moisture prior to dope preparation. Two dopes was prepared where the outer layer comprised of 15wt% of PVDF/ 3wt% of titanium dioxide while the inner layer was 18wt% of PVDF and the rest was dimethylacetamide (DMAc) solution. Firstly, the  $TiO_2$  and DMAc were added in Scott bottle with an overhead stirrer. After the  $TiO_2$  mixture became a homogeneous solution, the desired amounts of polymer was added to the solution. Then, the solution was degassed by using ultrasonic bath system at ambient temperature over night prior to spinning. The spinning dope mixture was extruded using a triple orifice spinneret to form dual layer hollow fiber membranes as stated detail elsewhere (Dzinun et al., 2015). Three types of hollow fibers were fabricated which are (i) dual layer nanocomposite PVDF/ $TiO_2$  hollow fiber (DL-T3), (ii) single layer nanocomposite PVDF/ $TiO_2$  hollow fiber (SL-T3) and (iii) dual layer pristine PVDF hollow fiber (DL-T0). For the nanocomposite membrane, 3wt.% of  $TiO_2$  was used together with 15wt.% of PVDF in dimethylacetemide (DMAc) solvent.

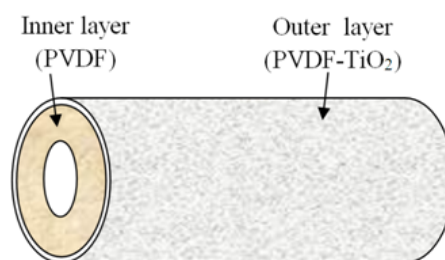

Figure 1: Illustration of dual layer nanocomposite hollow fiber

### 2.2 Characterization Methods

The morphology of the cross section membranes were inspected by SEM (Model: TM 3000, Hitachi). The hollow fibres were immersed in liquid nitrogen for 10 min and then fractured into short samples, for the purpose of maintaining the original cross sectional of the membranes. The samples were then positioned on a metal holder and sputter coated with gold under vacuum for 3 min. The micrographs of the cross section and surface of the hollow fibre membranes were taken at various magnifications. The images of membranes before and after UV irradiation were also captured for comparison purposes.

Contact angle measurements on the hollow fibre membranes were conducted using the contact angle goniometer (Model: OCA 15EC, Dataphysics) with deionized water as contact liquid. The water droplets of 2 L were dropped on the fibre surfaces. An average and standard deviation of at least 10 independent measurements was obtained at different points of one



sample.

Pure water flux experiments were conducted in a U-like membrane module filtration apparatus. For each module, twenty fibres with 30 cm length were assembled into the filtration module and pure water flux measurements were performed in a cross flow mode through outside-in configuration. The compressed distilled water will be used as permeate for pure water flux measurements. Membranes will initially pressurized with distilled water at 0.15MPa for 0.5h to compact membranes for getting a constant flux. The steady water fluxes will be measured at 0.1MPa and the flux will be calculated according to equation 1 and 2:

$$F = \frac{V}{Axt} \quad (1)$$

$$A = \Pi d_o L \quad (2)$$

where F is the membrane flux ( $L/m^2h$ ), V is the volume of permeate at time t (L), A is the effective filtration area of the membrane ( $m^2$ ),  $d_o$  is the outer diameter of hollow fibers (cm) and L is the effective length of hollow fibers (cm).

### 2.3 Nonylphenol Rejection

Nonylphenol(NP) rejection test is the same as water permeability test. A 1 ppm of feed solution was prepared by dissolving 1 g nonylphenol (NP) in 1L of volume. Permeate was collected after 30 minutes and examined using a HACH DR5000 UV-Vis spectrophotometer. The scanning determination of absorbance at a fixed wavelength at 282nm. NP rejection was calculated from the NP solution at initial feed 1ppm using the equation 3:

$$NP_{rejection} = \left( \frac{Abs_{permeate}}{Abs_{feed}} \right) \quad (3)$$

## 3 RESULTS AND DISCUSSION

Figure 2 shows SEM images of the PVDF/TiO<sub>2</sub> hollow fiber membranes with different configurations. As can be seen in the Figure 2 (a & b), both layers are compatible with each other and there are no delamination and interfacial resistance when PVDF was used for both inner and outer layer dopes. All hollow fiber membrane exhibits sandwich like structure that consists of finger like structure in the inner and outer layer, separated by sponge like structure. As stated in Table 1, single layer hollow fiber membrane was slightly thicker compared to dual layer PVDF/TiO<sub>2</sub> hollow fiber membranes and neat membranes. This thickness would affect the pure water flux and also NP rejection as can be discussed in the next section.

Surface hydrophilicity is a membrane property that influences flux and antifouling ability. It is evaluated by measuring the contact angle between water and membrane surface, wherein a decrease in angle indicates an increase in hydrophilicity. The contact angle data as stated in Table 1 shows that in addition of TiO<sub>2</sub> resulted to an improvement in the hydrophilicity due to the hydroxyl groups of TiO<sub>2</sub> nanoparticles on the membrane surface.

Even though the single layer hollow fiber is more hydrophilicity than the dual layer, the pure water flux results were not in good agreement with the hydrophilicity as shown in Figure 3. It may be due to the particle aggregation causing decrease in effective hydrophilic area

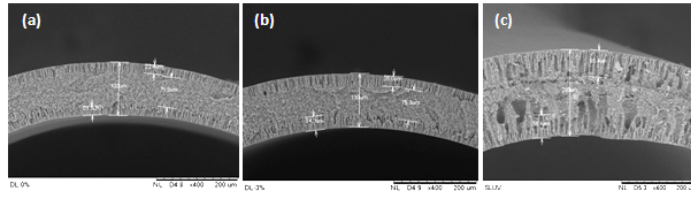

Figure 2: Partial cross sectional SEM images of the hollow fiber membranes with different configurations; (a) DL neat membrane, (b) DL TiO<sub>2</sub> 3wt%, (c) SL TiO<sub>2</sub> 3wt%

Table 1: Examples of writing table

Configuration	Membrane identification code	Thickness (m)	Contact angle (degree)
Dual Layer Hollow Fibre TiO <sub>2</sub> 3wt%	DL-T3	130	76.3
Dual Layer Hollow Fibre TiO <sub>2</sub> 0wt%	DL-T0	130	80.4
Single Layer Hollow Fibre TiO <sub>2</sub> 3wt%	SL-T3	209	71.7

and hydroxyl group number (Cruz et al., 2013). Besides, the pore size and macrostructure difference between these two membranes could be the main reason for such trend.

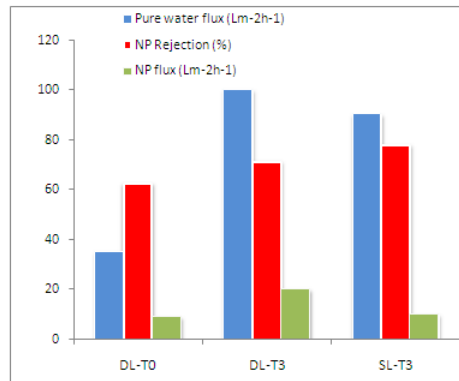

Figure 3: Pure water flux, NP flux and rejection by using different membrane configuration

The NP flux of nanocomposite dual layer hollow fibre (DL-T3) possesses the highest value compared to single layer and neat membrane. The obtained results clearly reveal that the antifouling property of TiO<sub>2</sub> in the dual layer hollow fiber membranes was significantly improved.

From Figure 4, the fouling behavior of the membrane can also be observed. In comparison to dual layer pure PVDF hollow fiber, it can be seen that the nanocomposite PVDF/TiO<sub>2</sub> membranes (both single and dual layer hollow fiber) have better anti-fouling property since the flux drops from minute 30 to minute 240 of the membranes with TiO<sub>2</sub> are much lower than the pure PVDF one. The result indicates that membrane fouling will increase drastically

with absence of  $TiO_2$ . In addition, the obtained results also shows that the dual layer hollow fiber that utilized much smaller amount of  $TiO_2$  (since  $TiO_2$  only dispersed on the thin outer layer) has a comparable anti-fouling property compared to single layer one, which used more amount of  $TiO_2$  due to its thicker nanocomposite thickness.

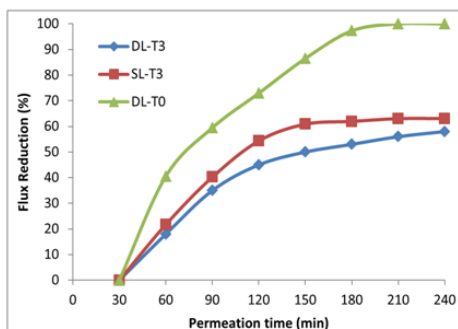

Figure 4: Flux behaviors during NP filtration

## 4 CONCLUSION

This work has focused on the effectiveness of  $TiO_2$  nanoparticles as an antifoulant in different membrane configuration. The experimental results showed that by addition of  $TiO_2$  in the membrane could enhanced the membrane hydrophilicity and resulted increase the flux. It revealed that  $TiO_2$  nanoparticles are more effective in the dual layer configuration. It will reduce the material cost due to the amount of  $TiO_2$  used in outer layer of dual layer hollow fibre membranes will be less than single layer.

## 5 ACKNOWLEDGEMENT

The authors gratefully acknowledge financial support from Research University Grant Tier 1 (Project number: Q.J130000.2509.05H53), Fundamental Research Grant Scheme (Project Number: R.J130000.7809.4F282) and technical support from Research Management Centre, Universiti Teknologi Malaysia. The authors also acknowledge Solvay Specialty Polymers Italy and Johnson Matthey PLC UK for providing materials used in this work.

## References

- Ahmad, a. L., & Ramli, W. K. W. (2013). Hydrophobic PVDF membrane via two-stage soft coagulation bath system for Membrane Gas Absorption of  $CO_2$ . *Separation and Purification Technology*, 103, 230240.
- Alhakimi, G., Studnicki, L. H., & Al-ghazali, M. (2003). *Photocatalytic destruction of potassium hydrogen phthalate using  $TiO_2$  and sunlight: application for the treatment of industrial wastewater*, 154, 219228.
- Bhandari, D., Olanrewaju, K. O., Bessho, N., Breedveld, V., & Koros, W. J. (2013). Dual

- layer hollow fiber sorbents: Concept, fabrication and characterization. *Separation and Purification Technology*, 104, 6880.
- Bonyadi, S., & Chung, T. S. (2007). *Flux enhancement in membrane distillation by fabrication of dual layer hydrophilic hydrophobic hollow fiber membranes*, 306, 134146.
- Cruz, N. K. O., Semblante, G. U., Senoro, D. B., You, S. J., & Lu, S. C. (2013). Dye degradation and antifouling properties of polyvinylidene fluoride/titanium oxide membrane prepared by solgel method. *Journal of the Taiwan Institute of Chemical Engineers*.
- Damodar, R. a, You, S.-J., & Chou, H.-H. (2009). Study the self cleaning, antibacterial and photocatalytic properties of TiO<sub>2</sub> entrapped PVDF membranes. *Journal of hazardous materials*, 172(2-3), 13218.
- Damodar, R. A., You, S., & Ou, S. (2010). Coupling of membrane separation with photocatalytic slurry reactor for advanced dye wastewater treatment. *Separation and Purification Technology*, 76(1), 6471.
- Dong, C., He, G., Li, H., Zhao, R., Han, Y., & Deng, Y. (2012). Antifouling enhancement of poly(vinylidene fluoride) microfiltration membrane by adding Mg(OH)<sub>2</sub> nanoparticles. *Journal of Membrane Science*, 387-388, 4047.
- Dzinun, H., Othman, M. H. D., Ismail, a. F., Hafiz Puteh, M., Rahman, M. a., & Jaafar, J. (2015). Morphological study of co-extruded dual-layer hollow fibre membranes incorporated with different TiO<sub>2</sub> loadings. *Journal of Membrane Science*.
- Fei, D., Chung, T., Wang, R., & Liu, Y. (2002). *Fabrication of fluoropolyimide / polyethersulfone (PES) dual-layer asymmetric hollow fiber membranes for gas separation*, 198, 211223.
- Ho, D. P., Vigneswaran, S., & Ngo, H. H. (2009). Photocatalysis-membrane hybrid system for organic removal from biologically treated sewage effluent. *Separation and Purification Technology*, 68(2), 145152.
- Husain, S. (2006). *MIXED MATRIX DUAL LAYER HOLLOW FIBER MEMBRANES FOR NATURAL GAS SEPARATION*.
- Jiang, L., Chung, T., Fei, D., Cao, C., & Kulprathipanja, S. (2004). *Fabrication of Matrimid / polyethersulfone dual-layer hollow fiber membranes for gas separation*, 240, 91103.
- Li, J.-H., Shao, X.-S., Zhou, Q., Li, M.-Z., & Zhang, Q.-Q. (2013). The double effects of silver nanoparticles on the PVDF membrane: Surface hydrophilicity and antifouling performance. *Applied Surface Science*, 265, 663670.
- Madaeni, S. S., Zinadini, S., & Vatanpour, V. (2011). A new approach to improve antifouling property of PVDF membrane using in situ polymerization of PAA functionalized TiO<sub>2</sub> nanoparticles. *Journal of Membrane Science*, 380(1-2), 155162.
- Masuelli, M., Marchese, J., & Ochoa, N. a. (2009). SPC/PVDF membranes for emulsified oily wastewater treatment. *Journal of Membrane Science*, 326(2), 688693.

- Ngang, H. P., Ooi, B. S., Ahmad, A. L., & Lai, S. O. (2012). *Preparation of PVDF TiO<sub>2</sub> mixed-matrix membrane and its evaluation on dye adsorption and UV-cleaning properties*, 197, 359367.
- Nghiem, L. D., Manis, a., Soldenhoff, K., & Schfer, a. I. (2004). Estrogenic hormone removal from wastewater using NF/RO membranes. *Journal of Membrane Science*, 242(1-2), 3745.
- Ong, Y. K., & Chung, T. (2012). High performance dual-layer hollow fiber fabricated via novel immiscibility induced phase separation ( I2PS ) process for dehydration of ethanol. *Journal of Membrane Science*, 421-422, 271282.
- Rahimpour, A., Jahanshahi, M., Mollahosseini, A., & Rajaeian, B. (2012). Structural and performance properties of UV-assisted TiO<sub>2</sub> deposited nano-composite PVDF/SPES membranes. *Desalination*, 285, 3138.
- Rahimpour, A., Jahanshahi, M., Rajaeian, B., & Rahimnejad, M. (2011). TiO<sub>2</sub> entrapped nano-composite PVDF / SPES membranes: Preparation , characterization , antifouling and antibacterial properties. *Desalination*, 278(1-3), 343353.
- Razmjou, A., Mansouri, J., & Chen, V. (2011). The effects of mechanical and chemical modification of TiO<sub>2</sub> nanoparticles on the surface chemistry, structure and fouling performance of PES ultrafiltration membranes. *Journal of Membrane Science*, 378(1-2), 7384.
- Sun, S. P., Hatton, T. A., Chan, S. Y., & Chung, T.-S. (2012). Novel thin-film composite nanofiltration hollow fiber membranes with double repulsion for effective removal of emerging organic matters from water. *Journal of Membrane Science*, 401-402, 152162.
- Vatanpour, V., Siavash, S., Reza, A., Salehi, E., Zinadini, S., & Ahmadi, H. (2012). TiO<sub>2</sub> embedded mixed matrix PES nanocomposite membranes: Influence of different sizes and types of nanoparticles on antifouling and performance. *Desalination*, 292, 1929.
- Wang, P., Teoh, M. M., & Chung, T. (2011). Morphological architecture of dual-layer hollow fiber for membrane distillation with higher desalination performance. *Water Research*, 45(17), 54895500.
- Widjojo, N., Chung, T., & Kulprathipanja, S. (2008). *The fabrication of hollow fiber membranes with double-layer mixed-matrix materials for gas separation*, 325, 326335.
- Wintgens, T., Gallenkemper, M., & Melin, T. (2002). *Endocrine disrupter removal from wastewater using membrane bioreactor and nanofiltration technology*, 146, 387391.
- Yan, L., Hong, S., Li, M. L., & Li, Y. S. (2009). Application of the Al<sub>2</sub>O<sub>3</sub>PVDF nanocomposite tubular ultrafiltration (UF) membrane for oily wastewater treatment and its antifouling research. *Separation and Purification Technology*, 66(2), 347352.
- Yuliwati, E., & Ismail, a. F. (2011). Effect of additives concentration on the surface properties and performance of PVDF ultrafiltration membranes for refinery produced wastewater treatment. *Desalination*, 273(1), 226234.

## Chemical Degradation of SPEEK/CLOISITE/TAP Membrane Under Fenton Reagent Accelerated Stress Test

Muhammad Taufiq Salleh, Juhana Jaafar, Noorul Anam  
Mohd Norddin, Ahmad Fauzi Ismail, Mohd Hafidz Dzarfan  
Othman, Mukhlis Abdul Rahman, Norhaniza Yusof, Wan  
Norharyati Wan Salleh

Advanced Membrane Technology Research Centre (AMTEC)  
Universiti Teknologi Malaysia (UTM), 81310 Skudai, Johor.  
e-mail: juhana@petroleum.utm.my

### **Abstract**

*The chemical degradation of SP/CL/TAP membrane had been studied using accelerated stress test (AST) to reduce the testing time for membrane degradation. The membrane was prepared using solution intercalation method. The membrane was immersed into Fenton Reagent solution (5% H<sub>2</sub>O<sub>2</sub>, 50 ppm FeSO<sub>4</sub>) as a function of time in order to simulate the chemical radical attack on the membrane inside DMFC system. The commercial Nafion® 117 was used as reference membrane. It was found out that the SP/CL/TAP membrane weight reduced by 6% after being immersed in Fenton Reagent for 6 hours. FESEM image of the SP/CL/TAP and Nafion® showed severe development of pinholes on the surface of the membranes after 6 hours of degradation. Both of the membranes showed similar proton conductivity deterioration behaviour; SP/CL/TAP proton conductivity dropped from 5.76x10<sup>-4</sup> S/cm to 3.36x10<sup>-4</sup> S/cm, while Nafion® dropped from 7.46x10<sup>-4</sup> S/cm to 5.20x10<sup>-4</sup> S/cm under 3 hours degradation testing and remained constant towards the end of the testing. This shows that the performance of the SP/CL/TAP membrane under DMFC severe degradation environment was found comparable to the commercial Nafion® membrane. Thus, it can be concluded that the SP/CL/TAP membrane is a potential proton exchange membrane for long term usage in DMFC system.*

**Keywords :** SPEEK, composite membrane, degradation, Fenton Reagent, Nafion

## 1 INTRODUCTION

Direct methanol fuel cell (DMFC) is a very promising replacement for lithium battery due to ease of refuelling and handling, high energy density, and high efficiency. Furthermore, DMFC itself is a power generation device, thus it eliminates the need to constantly charging

from the grid to store energy and improves the mobility of mobile devices. Department of Energy (DOE), United States of America (USA) has put 5,000 hours of operating time as minimal requirement for DMFC before it can be commercialized (Xiao-Zi Yuan et al., 2011). In order to understand the degradation behaviour of DMFC, accelerated stress test (AST) had been introduced. Under AST testing, the DMFC operation will be conducted under severe operating condition, i.e. high electrical loading, extreme relative humidity (RH) changes, high radical environment, etc. Using AST test had been able to shorten the lifetime testing of DMFC and at the same time are able to understand better degradation behaviour of DMFC.

In DMFC operation, partial reduction of  $O_2$  gas at cathode side will form  $H_2O_2$ . Due to acidic condition during DMFC operation, the iron back plate have tendencies to be corroded, thus forming  $Fe^{2+}$  ion at anode side. The  $Fe^{2+}$  ion then will react with  $H_2O_2$  to form radicals which will attack the break up the membrane polymer chain, causing pinholes formation on the membrane which will degraded the DMFC performance. Equation (1), (2) and (3) show the chemical reaction for  $H_2O_2$  and radical formation inside DMFC.

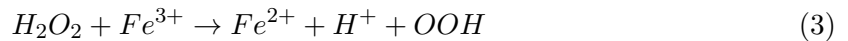
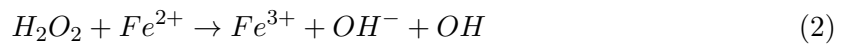

Fenton Reagent test is one of the testing under AST use to study the chemical degradation behaviour of membrane electrode assembly (MEA), one of the important component in DMFC. By adding iron salt into  $H_2O_2$  solution, it will prompt the formation of  $OH\bullet$  and  $OOH\bullet$  radicals, thus mimics the radical formation in DMFC operation. Many research had been conducted to study the chemical degradation behaviour of the membrane using Fenton Reagent test. Haolin Tang et al. (2007) found out that the their Nafion®/PTFE membrane showed lower F- formation compared to Nafion® 111 membrane after immersed in Fenton Reagent for 72 hours. F- is one of the indicator that the radicals are breaking up the PFSA polymer chain, since the PFSA membrane consists of fluorine based polymer. Wang et al. (2008) study the chemical degradation on Nafion® 111 membrane. Based on their findings, the Nafion membrane showed high formation of pinholes after 48 hours of testing. The pinholes formation was the reason for increase in  $H_2$  gas crossover and reduction of membrane mechanical strength.

Juhana Jaafar et al. (2011) developed a new novel SPEEK/Cloisite® 15A/TAP membrane for DMFC system. This new nano-composite membrane showed better proton conductivity and methanol permeability characteristics compared to Nafion® 112 membrane. Thus, this new membrane showed promising opportunities to be a viable replacement for Nafion® in DMFC applications. Since that membrane durability and lifetime is the important requirement for DMFC operation, it is crucial to conduct research to study the chemical degradation behaviour of SP/CL/TAP membrane using Fenton Reagent test.

## 2 METHODOLOGY

### 2.1 Materials

Poly (ether ether ketone) (PEEK) in powder form was obtained from Vitrex Inc., USA. Concentrated sulfuric acid ( $H_2SO_4$ ) (95.97%) purchased from QREX. Dimethylsulfoxide (DMSO) was obtained from Sigma-Aldrich as solvent for solution preparation. Cloisite 15A® was obtained from Southern Clay Products, Inc. 2,4,6-Triaminopyrimidine (TAP) in powder form was obtained from Sigma-Aldrich and was used as a compatibilizer for producing nanocomposite membranes.

### 2.2 Membrane preparation

Sulfonation reactions were conducted using  $H_2SO_4$  as the sulfonating agent. A mixture of 50 g PEEK and 1000 mL  $H_2SO_4$  was stirred at room temperature for 1 h. Then the solution was continuously stirred at  $55^\circ C$  for 3 h. The sulfonated polymer was recovered by precipitating the acid polymer solution into a large excess of ice water. The resulted SPEEK polymer was filtrated and washed thoroughly with deionized water until the pH became 6.7. Finally, the sulfonated PEEK was dried in the drying oven at  $80^\circ C$  for 24 h.

For membrane preparation, a 10 wt% of SPEEK solution was first prepared by dissolving 10 g SPEEK in 60 mL DMSO and stirred at  $60^\circ C$  for 24 h. 0.25 g of Cloisite 15A and 0.5 g of TAP was dissolved in 15 mL DMSO in 2 different container to produce 1 wt% solutions. The solutions was stirred for 24 h at  $60^\circ C$  to ensure its homogeneity before being added to the SPEEK solution. The final 90 mL mixture of SPEEK, Cloisite and TAP solutions was vigorously stirred for 24 h at  $60^\circ C$  to produce a homogeneous solution.

To produce the SP/CL/TAP membrane, the solution was casted on a glass plate with a casting knife to form a solution film. The result film then dry in a vacuum oven for 24 hours at  $80^\circ C$ , and another 6 hours at  $100^\circ C$  to remove any residual solvent completely. After that, the film is detached from the casting glass by immerse into the water. The film then undergoes another drying process for 3 days at  $80^\circ C$  in a vacuum oven. For the final process, the new form film is treated in 1 M sulphuric acid ( $H_2SO_4$ ) solution for 1 day at room temperature subsequently rinse with water several times to remove any remaining acid on the film and to assure all the sulfonate group is in H form.

### 2.3 Chemical degradation test

Fenton Reagent test had been used to study the chemical degradation behaviour of SP/CL/TAP membrane. The SP/CL/TAP and Nafion® membrane was dried for 24 hours at  $60^\circ C$  to remove remaining moisture. 5% of hydrogen peroxide ( $H_2O_2$ ) and 50 ppm iron sulphate ( $FeSO_4$ ) was used to prepare the Fenton Reagent solution. Both membrane were weigh before being immersed in Fenton Reagent solution for 6 hours. Each hour, the test will be stopped and the membranes will be taken out from the solutions and rinsed under excessive water to stop the degradation process. The degraded membranes then were dried and be taken to weight measurement and proton conductivity test. After that, the membrane were immersed in new Fenton Reagent solution and the process was repeated until 6 hours of testing ends.



## 2.4 Morphological study

The morphology of SP/CL/TAP and Nafion® membranes was investigated using a field emission scanning electron microscope (FESEM) (JSM-6701F, JEOL USA, Inc.). Specimens for the morphological analysis were prepared by freezing the dry membrane samples in liquid nitrogen and breaking them for a cross-section image analyses. Fresh cross-sectional cryogenic fractures of the membranes were vacuum sputtered with a thin layer of gold before FESEM examination.

## 2.5 Proton conductivity study

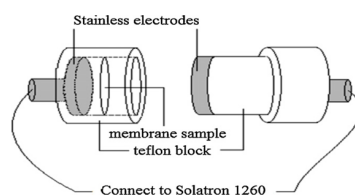

Figure 1: Schematic diagram of proton conductivity cell.

Transverse proton conductivity (PC) of the membrane samples was measured by Solatron 1260 Impedance instrument over a frequency range of 1 Hz to 107 Hz with 50 mV - 500 mV oscillating voltage. The hydrated membrane was sandwiched between two stainless steel block electrodes as shown in Fig. 1. The conductivity,  $\sigma$ , of samples in the transverse direction was calculated from the impedance data, using the relationship:

$$\sigma = \frac{d}{RS} \quad (4)$$

where  $d$  and  $S$  are the thickness and face area of the membrane sample, respectively, and  $R$  is derived from the low intersection of the high frequency semi-circle on a complex impedance plane with the  $\text{Re}(Z)$  axis. The resistance of each membrane sample was obtained by using interpolation method in Frequency Response Analyzer (FRA) software.

## 3 RESULTS AND DISCUSSION

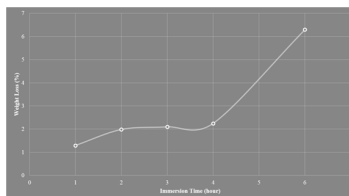

Figure 2: Weight loss of SP/CL/TAP membrane

### 3.1 Fenton Reagent test

Figure 2 showed the weight loss of SP/CL/TAP membrane after 6 hours Fenton Reagent test. The SP/CL/TAP membrane has lost its weight around 6.5% from its initial condition. The weight reduction can be related to the radicals activity in Fenton Reagent solution. The  $OH\bullet$  and  $OOH\bullet$  radicals are unstable molecules, thus this radicals will attacked SP/CL/TAP membrane polymer chain to receive the remaining missing valence to formed water. The attacked chain will break up from the membrane, thus reduced the membrane weight after being immersed in Fenton Reagent solution. Same findings also being made by Wang et al. (2008) and Tang et al. (2007), where they observed the formation of F- ion inside the Fenton Reagent solution of the test, which comes from the Nafion® polymer chain after being break up by the radicals.

### 3.2 Morphological analysis

Figure 3 showed the FESEM image of SP/CL/TAP and Nafion® membrane before and after 6 hours of Fenton Reagent test. Both membranes showed formation of pinholes and deformation of membrane surface after being exposed to Fenton Reagent after 6 hours. Same observation also being reported by Wang et al. (2008) which showed the pinholes formation and severe deformation of Nafion® membrane on its surface. This is because both membranes have undergoes chemical degradation process due to  $OH\bullet$  radical attack to the membrane polymer chain. The formation of pinholes and deformation of membrane surface on Nafion® membrane are more severe than SP/CL/TAP membrane. This might happen because of incorporation of Cloisite membrane inside SPEEK polymer chain gives the SP/CL/TAP membrane better resistant towards radical attack, thus gives SP/CL/TAP membrane better chemical degradation resistance than Nafion® membrane.

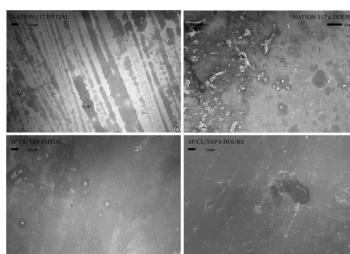

Figure 3: FESEM image for Nafion (a) before and (b) Fenton Reagent test. Image (c) and (d) is the FESEF image of SP/CL/TAP membrane before and after Fenton Reagent test, respectively.

### 3.3 Proton conductivity analysis

The SP/CL/TAP and Nafion® membrane PC reduction characterisation are shown in Figure 4. It is observed that both SP/CL/TAP and Nafion® membrane showed same degradation behaviour, with SP/CL/TAP membrane PC dropped from  $5.76 \times 10^{-4}$  S/cm to  $3.36 \times 10^{-4}$  S/cm, while Nafion® membrane PC dropped from  $7.46 \times 10^{-4}$  S/cm to  $5.20 \times 10^{-4}$  S/cm in 3 hours testing, before being constant towards the end of the 6 hours testing. The degradation behaviour can be related to the detachment of  $SO_3$  acid group and pinholes

formation on the membrane, which reduced the conductance side of the membrane. Tang et al. (2007) also added that the pinholes formation on the membrane not only reduce the conductance side of the membrane, but also allowed the reactant to cross over and reduce the mechanical strength of the membrane.

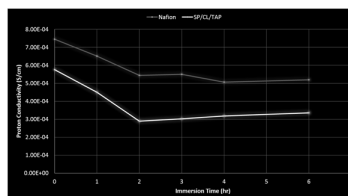

Figure 4: Degradation behaviour of proton conductivity for Nafion and SP/CL/TAP membranes under Fenton Reagent test

#### 4 CONCLUSION

From the findings, it can be shown that the new SP/CL/TAP membrane has good chemical degradation resistance under DMFC conditions. The FESEM image of SP/CL/TAP membrane shown less pinholes formation than Nafion® membrane. The membrane also did not show visible surface deformation as compared to Nafion® observation. For proton conductivity characteristics, the SP/CL/TAP membrane shown similar performance degradation behaviour as Nafion® membrane. Thus, it can be concluded that the SP/CL/TAP membrane is a potential proton exchange membrane for long term usage in DMFC system.

#### 5 ACKNOWLEDGEMENT

The authors are thankful to Universiti Teknologi Malaysia (UTM) and Ministry of Education (MOE), Malaysia for the generous financial sponsorship through R.J130000.7809.4F592 in conducting this research project.

#### References

- Fang Wang, Haolin Tang, Mu Pan, and Daoxi Li (2008), Ex situ investigation of the proton exchange membrane chemical decomposition, *International Journal of Hydrogen Energy*, 33, 2283-2288.
- Haolin Tang, Mu Pan, Fang Wang, Pei Kang Shen, and San Ping Jiang (2007), Highly Durable Proton Exchange Membranes for Low Temperature Fuel Cells, *Journal of Physical Chemistry B*, 111, 8684-8690.
- Juhana Jaafar, A.F. Ismail, T. Matsuura, and K. Nagai, (2011). Performance of SPEEK based polymer nanoclay inorganic membrane for DMFC, *Journal of Membrane Science*, 382, 202-211.
- Xiao-Zi Yuan, Hui Li, Shengsheng Zhang, Jonathan Martin, and Haijiang Wang (2011), A review of polymer electrolyte membrane fuel cell durability test protocols, *Journal of Power Sources*, 196, 9107-9116.

## The Characteristics Study of Titanium Dioxide Nanofibers Prepared by Electrospinning Method

Nor Azureen Mohamad Nor , Juhana Jaafar,  
Ahmad Fauzi Ismail, Mohd Hafiz Dzarfan Othman,  
Mukhlis A. Rahman, Wan Norharyati Wan Salleh, Norhaniza  
Yusof, Lau Woei Jye

Advanced Membrane Technology Research Centre (AMTEC)  
Universiti Teknologi Malaysia, 81310 UTM Johor Bahru, MALAYSIA  
Faculty of Petroleum and Renewable Energy Engineering  
Universiti Teknologi Malaysia  
81310 UTM Skudai, Johor Bahru, Malaysia  
e-mail: juhana@petroleum.utm.my

### **Abstract**

*Titanium dioxide nanofibers with diameter ranging to several nanometers were synthesized via electrospinning technique. The precursor solution was prepared by mixing the polyvinylpyrrolidone, PVP (MW~1,300,000) in ethanol, meanwhile titanium tetraisopropoxide, TTIP in acetic acid was slowly added into the solution under a vigorous stirring. The precursor solutions were then used in the electrospinning process under high voltage supply. As-spun nanofibers were heat-treated under different temperature 400°C, 500°C and 600°C. The TiO<sub>2</sub> nanofibers were characterized by using scanning electron microscopy (SEM), BrunauerEmmettTeller (BET) and X-ray diffraction (XRD). The results indicated that the heat treated TiO<sub>2</sub> nanofibers consist of anatase and rutile phases. As the calcination temperature increased (400–500°C), the anatase phases are greater than rutile phase and specific surface area are decreases while the calcination process influenced the nanofibers diameter.*

**Keywords :** *Titanium dioxide, nanofibers, electrospinning, calcination temperature*

## 1 INTRODUCTION

Over the past decades, nanomaterials show the potential for wide ranging industrial, biomedical and electronic applications. It has attracted the attention of many people especially researcher to further research and improve the uses of the nanostructured. Nanostructured such as nanoparticles (Rao and Geckeler, 2011), nanowires (Wu et al., 2012), nanofibers (Wang et al., 2013), and nanotubes (Long et al., 2011) only have size ranging from 1-100 nm. Nanostructured is used as a catalyst in order to improve the process efficiencies because of

the small particles will lead to a greater surface area for the reaction between pollutants and catalyst (Shen et al., 2014). Due to higher active surface area, nanomaterial is lead to its ability for reducing the toxicity of pollutants to safer level and at a very reasonable cost (Kriklavova and Lederer, 2011). Nanofibers membrane is one of the advanced technologies used because of the small pore size and has very large surface area to volume ratio (Lev et al., 2011). It also has a good flexibility of its surface function and high mechanical performance such as tensile strength (Huang et al., 2003). The excellent features of nanofibers have led to many important applications technology development.

The presence nanofibers have change the fascinating characteristics on the fibers surface such as flexibility of the surface and also providing a very large surface area to volume ratio (Fridrikh et al., 2003). There are several techniques to produce nanofibers such as melt blowing, forcespinning and electrospinning. Heated air blows were used to produce nanofibers in melt blown process (Ellison et al., 2007) while forcespinning technique using the centrifugal forces to turn the material into nanofibers (Padran et al., 2013). Electrospinning is the simplest and attractive method in order to produce fibers which is the diameters is about 10 $\mu$ m to 10nm simply by accelerating a jet of charged precursor solution in an electric field (Nor et al., 2013, Vonch et al., 2007). This paper discussed about the physical properties of the prepared TiO<sub>2</sub>nanofibers which were characterized by SEM, BET and XRD.

## 2 EXPERIMENTAL PROCEDURE

### 2.1 Precursor Solution

In this study, polyvinylpyrrolidone (MW $\sim$  1,300,000, PVP), titanium tetraisopropoxide (TTIP), ethanol and acetic acid from Sigma-Aldrich were used as the starting materials. PVP/ethanol was prepared by mixing 12wt% of PVP to ethanol and was stirred about 2 hours until dissolved. On the other side, TTIP and acetic acid was mixed using ratio of 1:2 of TTIP /acetic acid and stir for 1 hour. TTIP/acetic acid solution was then added to the PVP/ethanol solution and vigorously stirred prior to the TiO<sub>2</sub>nanofibers precursor preparation. The basic experimental procedure was discussed elsewhere in which there were some modifications on the original experimental conditions (Liu et al., 2012, Park and Wim, 2009).

### 2.2 Electrospinning

The precursor solutions were loaded into the plastic syringe with the 21-gauge needle made from stainless steel. The syringe was placed onto the syringe pump with a constant flow rate of 1.0 mL/h and the stainless steel needle was connected to the high voltage supply. The voltage supply is set at 15-20kV and a piece of flat aluminium foil was connected to the ground at 15-20cm distance from the needle tips as the nanofibers collector. The electrospinning process was carried out at room temperature. The obtained as-spun nanofibers were left in the ambient air for one day. In order to remove the polymer content, the as-spun TiO<sub>2</sub>nanofibers was undergo the heat treatment process. The calcination parameters were varied to identify the effect of different heat treatment process on the TiO<sub>2</sub>nanofibers morphology.

## 2.3 Calcination

During the calcination of the  $TiO_2$ /PVP nanofibers, the PVP which is as an organic phase was selectively burned out while the remaining  $TiO_2$  is evolved into polycrystalline. The diameter of the nanofibers will reduce due to the removal of the PVP and sintering the  $TiO_2$  phase. The calcination will take place in  $400^\circ C$  and  $500^\circ C$  for 3 hour to remove the PVP. The most important characteristics in the nanofibers such as the phase and surface roughness in which they can be controlled by adjust the temperature and the calcination time.

## 3 RESULT AND DISCUSSION

Figure 1 shows the SEM images of the  $TiO_2$  nanofibers before and after undergone heat treatment at different temperature for one hour. Fibers without the calcination process showed a smoother and homogeneous surface because it still contained the polymer binder which is PVP (Li and Xia, 2003). The average diameter of the as-spun nanofibers without calcination was approximately between 200 nm to 1 $\mu m$ . In contrast, after the heat treatment it can be seen that the nanofibers shrinking and the diameter became smaller which is the average diameter was about 100nm to 400nm. As the temperature increased, the average diameter of the calcined nanofibers became smaller because of the decomposition of the organic components that presents in the nanofibers (Hu et al., 2013, Nuansing et al., 2006).

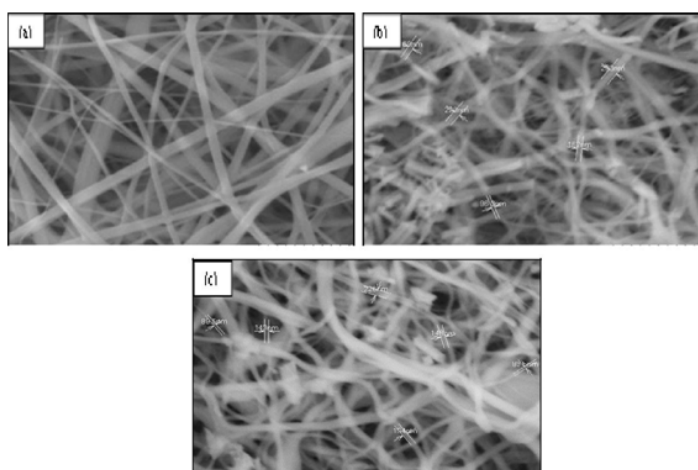

Figure 1: SEM images of  $TiO_2$  nanofibers a) before calcination and at different calcination temperature b)  $400^\circ C$  and c)  $500^\circ C$

The BrunauerEmmettTeller (BET) surface analysis of the sample were examined using nitrogen gas with the composition of 30%  $N_2$ , 70% He. The analysis were conducted for one hour at room temperature ( $24^\circ C$ ) with the outgas temperature is ( $130^\circ C$ ). The specific surface area characterized by BET as a function of calcination temperature was illustrated in Table 1. It was

found that as the calcination temperature increased, the specific surface area of the  $TiO_2$  nanofibers decreased. This was due to the increasing in the particle size of the fibers and also the degree of agglomeration occurring in the material is increase (Gaber et al., 2014).

Table 1: Single point surface area data by using nitrogen gas by BET

Sample	Calcination Temperature( $^{\circ}C$ )	Surface Area ( $m^2/g$ )
1	400	52.32
2	500	44.17
3	600	8.93

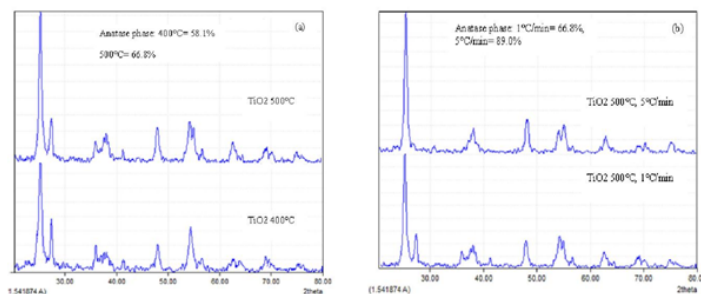

Figure 2: XRD patterns of  $TiO_2$  nanofibers at different calcination temperature a)  $T=400^{\circ}C$ ,  $500^{\circ}C$  and different heating rate b)  $T=5500^{\circ}C$  ( $1^{\circ}C/min$ ,  $5^{\circ}C/min$ )

XRD patterns of  $TiO_2$  nanofibers at different temperature and heating rate of heat treatment are shown in figure 2. From figure 2(a) and 2(b), XRD patterns exhibit strong diffraction peaks at  $25^{\circ}$ ,  $38^{\circ}$  and  $54^{\circ}$  indicating that the  $TiO_2$  nanofibers is in the anatase phase. Meanwhile, strong diffraction peaks at  $27^{\circ}$ ,  $36^{\circ}$  and  $55^{\circ}$  indicate that the  $TiO_2$  nanofibers is in the rutile phase (Thamaphat et al., 2008, Hanaor and Sorrell, 2001). Figure 2 also shows that as the calcination temperature slightly increase, the diffraction pattern peak intensity that corresponding to the anatase phase was increased. The prepared sample showing the peaks characteristics of both anatase and rutile phase of the  $TiO_2$  nanofibers. Based on figure 2(a), the temperature of the calcination increased from ( $400^{\circ}C$  to  $500^{\circ}C$ ), the percentage of the anatase phase was also increased. The percentage of the anatase phase comparisons was made among the nanofibers after heat treated at 500C with the different heating rate (see figure 2(b)), it can be seen that the anatase phase is greater with the higher heating rate. It can be concluded that heating rate of calcination process an important role in producing highly pure anatase phase of  $TiO_2$ .

#### 4 CONCLUSION

$TiO_2$  nanofibers were prepared successfully via simple and efficient electrospinning method by using PVP and TTIP as started materials and heat treated under different temperature. The experimental results showed that smoother and homogeneous surface of  $TiO_2$  nanofibers were formed before undergone the calcination process. Based on SEM images, the diameter of the nanofibers is decreasing upon heat treatment process. BET specific surface area analysis showed that the specific surface areas of the nanofibers were decreased with the increasing calcination temperature. XRD analysis have proved that both anatase and rutiles phase have

been obtained after the heat treatment.

## 5 ACKNOWLEDGEMENT

The authors are thankful to the Ministry of Science, Technology and Innovation Malaysia (MOSTI), Ministry of Education (MOE) and UniversitiTeknologi Malaysia under Science Fund Program (Project Number: R.J130000.7942.4S057). The authors also acknowledge technical and management support from Research Management Centre (RMC), UniversitiTeknologi Malaysia.

## References

- Ellison, C.J., Phatak, A., Giles, D.W., Macosko, C.W. and Bates, F.S. (2007). *Polymer* 48: 3306-3316.
- Fridrikh, S.V., Yu, J.H., Brenner, M.P. and Rutledge, G.C. (2003). *Physical Review Letters* 90:14.
- Gaber, A., Rahim, M.A.A., Latief, A.Y.A. and Salam, M.N.A. (2014). *Int. J. Electrochem. Sci.* 9: 81-95.
- Hanaor, D.A.H. and Sorrell, C.C. (2011). *J. Mater Sci.* 46: 855-874.
- Hu, M.L., Fang, M.H., Tang, C., et al. (2013). *Nanoscale Res Lett.* 8(1): 548.
- Huang, Z.M., Zhang, Y.Z., Kotaki, M. and Ramakrishna, S. (2003). *Composites Science and Technology* 63: 2223-2253.
- Kriklavova, L. and Lederer, T. (2011). Nanocon2011, 3rd International Conference, Czech Republic.
- Lev, J., Holba, M., Kalhotka, L., Szostkova, M. and Kimmer, D. (2011). Nanocon2011, 3rd International Conference, Czech Republic.
- Li, D. and Xia, Y. (2003). *Nano Letters* 3: 555-560.
- Liu, S., Liu, B., Nakata, K., Ochiai, T., Murakami, T. and Fujishima, A. (2012). *Journal of Nanomaterials*, Article ID 491927, Hindawi Publishing Corporation.
- Long, Y.Z., Li, M.M., Gu, C., et al., (2011). *Progress in Polymer Science* 36: 1415-1442.
- Nor, N.A.M., Jaafar, J., Othman, M.H.D. and Rahman, M.A. (2013). *Jurnal Teknologi.* 16: 4.
- Nuansing, W., Ninmuang, S., Jaremboon, W., Maensiri, S. and Seraphin, S. (2006). *Materials Science and Engineering B* 131: 147-155.
- Padron, S., Fuentes, A., Caruntu, D. and Lozano, K. (2013). *Journal of Applied Physics* 113, 024318.
- Park, J.Y. and Kim, S.S. (2009). *Met. Mater. Int.* 15: 95-99.



- Rao, J.P. and Geckeler, K.E. (2011). *Progress in Polymer Science* 36: 887-913.
- Shen, S., Sun, K., Zhang, H. and Ling, Y. (2014). *Advances in Condensed Matter Physics*. Article ID 902729. Hindawi Publishing Corporation.
- Thamaphat, K., Limsuwan, P. and Ngotawomchi, B. (2008). *Kasetsart J. (Nat. Sci.)* 42: 357-361.
- Vonch, J., Yarin, A. and Megaridis, C.M. (2007). *Journal of Undergraduate Research* 1, 1.
- Wang, P., Wang, Y. and Tong, L. (2013). *Light: Science & Applications* doi:10.1038/lssa.2013.58.
- Wu, H.B., Hng, H.H. and Lou, X. W. (David). (2012). *Advanced Materials* 24: 2567-2571.

# Design of Experiment (DOE) of Compressive Strength Test For Block Paving Prototype Using Thermoplastic Waste

**Dian Janari**

Department of Industrial Engineering, Faculty of Industrial Technology  
Universitas Islam Indonesia  
Yogyakarta  
Email:kerjadian@gmail.com

## ***Abstract***

*Waste is considered as consequences on humans activities, infrastructure developments, the raise of population and life style. Those are the determination factor for waste volume enlargement. Based on data of environmental status in 2012 that released by Environmental Board Yogyakarta province, industrial waste B3 in Yogyakarta province are accumulated as 200 ton/year and 15% of them in industrial plastic waste. Recycling process is important to be performed to reduce the wastes volume. Recycling is presumed as a process to turn waste into new product. One of the plastic wastes utilization is by using it as one of the mixture materials of block paving. The quality of block paving is determined by its compressive strength. Factors that influence the quality of its compressive strength are; type of cement, drying period, composition of water, cement, coarse aggregate, fine aggregate and plastic waste. Based on data analysis, several conclusions can be resumed. The Normality test resulted  $p=0,2515$  ( $p > 0,05$ ), it can be concluded as normal. Homogeneity test resulted  $p$  of 1,365 on significance level of 0,05, it can be concluded as homogenous. Best formulation for combination of optimum factor level, which is based on analysis of signal to noise ratio (SNR) and effect value on each factor is A2, B2, C1, D2, E1, F2, G1. The composition is explained as the mixture of Portland cement with 35 days drying duration, 0,5 litres water, 0,6 kg cement, 1,6 kg coarse aggregate, 1,1 kg fine aggregate and 300 gr plastic waste.*

**Keywords :** *plastic waste, signal to noise ratio (SNR), compressive strength, block paving*

## **1 INTRODUCTION**

Waste is considered as consequences on human activities, the raise of population and life style. Those are the determination factors for waste volume enlargement (Sari, Setiyawan 2011), besides, the rapid development on construction field (Soebandono, et al, 2013) resulted on the increasing of activities and improvements of building constructions that will cause the

raise of plastic waste (Putra, et al. tt). Based on data of environmental status that released by Environmental Board Yogyakarta province, in 2012 industrial waste B3 in Yogyakarta province are accumulated as 200 ton/year and 15% of them are industrial plastic waste (BLH, 2012). The ministry of Environment (KLH) assumes that everyday, Indonesian people produce 0,8 kg waste, or totally 189 thousand ton waste/day. From that calculation, 15% of them are plastic waste or equal to 28,4 thousand ton plastic waste/day (Suroño, 2013). Daily fact reveals that domestic and industrial wastes, both organic and non-organic are thrown away in the same waste container and mixed (Zubair and Haeruddin, 2002). Recycling process is very important to be performed to reduce the wastes volume. Recycling is presumed as a process to turn waste into new product (SNI-19-2454, 2002). Plastic is a well-known material that is recognized and used by all people. It strong, light, flexible, anti-corrosive, hard to break, easy to be colored, shapeable, heat isolator and electrical isolator (Suroño, 2013). Block paving is a composition of construction that built from the mixture of Portland cement or hydraulic glue (SNI-03-0691, 1996). Block paving can be constructed from needle leaf tree that is not decay, uncovered with mold, not parted or cracked (SNI ISO 5328:2013). Block paving is manufactured under two methods: traditionally and modern.

The research of Syukur Sebayang, 2011 was conducted by comparing traditional and machine block paving manufacturing. From the research, the quality specification III was resulted, the traditional manufacturing performed compressive strength of 21, 26 Mpa and 23, 07 Mpa for machine (Sebayang et al, 2011). Plastic waste is also used for vertical drainage. The research showed that soil improvement method, which was used vertical drainage that employed plastic waste as the filler, was better than vertical drainage that applied coconut fiber and sand to accelerate the lowering. It emphasized by the raise of vertical consolidation coefficient as 812, 414% if compared with consolidation coefficient on soft round without vertical drainage (Maheri, 2012). The research that conducted by Pratikno, 2010 stated that the utilization of plastic waste PET on concrete building will produce light concrete with density of 1700 kg/m<sup>3</sup>, the decreasing of concrete density will reduce the moment of inertia when the earthquake taken place (Pratikno, 2010). Bagus Soebandono, et al, 2013 observed on the combination of compressive strength behavior with tension of concrete that mixed with plastic waste HDPE. It can be concluded that the value of compressive strength will decrease as the increasing of plastic waste HDPE amount (Soebandono, et al, 2013). Yessi Rismayasari et al, 2012 stated that concrete construction, which used the waste plastic of polypropylene (pp) under variation of 0%, 2%, 4%, 6%, 8%, 10% by using Portland cement type 1, resulted density value ranged between  $(16 \pm 6) \times 10^2 \text{ kg/m}^3$  upto  $(22 \pm 4) \times 10^2 \text{ kg/m}^3$ . Compressive strength ranged between  $(16 \pm 0,1) \times 10^6 \text{ N/m}^2$  up to  $(21,8 \pm 0,2) \times 10^6 \text{ N/m}^2$  (Rismayasari, et al, 2012). The construction of rough specimen employs mix concrete or locked concrete beam such as block paving, grass block (Sebayang, 2011).

Generally, design of experiment (DOE) by using quality engineering technique is the description of product quality or production process on designated product. Quality is defined as the description of direct product characteristics such as: performance, reliability, easy to use, esthetics and others. While, strategic quality is defined as everything that able to fulfill customers expectation and necessities (meeting the needs of customers) (Gesperz V., 2001). Quality control is divided into two categories: off-line controlling and on-line controlling. Off-line controlling is divided into three stages, as follows: first stage is designing the concept, ideas and product development based on customer. Second stage is parameter

design and third stage is tolerance design. On line quality design is the activity of direct supervision for production process (Belavendram, N. 1995., Peace, G. 1993., dan Ross, P. 1998). Quality control should in line with design of experiment scheme, so the result of quality design could be well monitored (Sudjana, 1991). Design of experiment is classified into two, which are: conventional design of experiment and taguchi design of experiment. In Taguchi, orthogonal array is employed as the calculation to determine the minimum experiments to obtain maximum information (Peace, G, 1993). The Philosophy of Taguchi is to design the quality inside the product, the cost reducing should be measured in all system and the product should well designed so the product robust can be controlled (Montgomery, 1998). The purpose of this research is to design block paving prototype using aggregate thermoplastic waste and to conduct quality engineering on block paving compressive strength that uses aggregate thermoplastic waste.

## **2 RESEARCH METHODOLOGY**

### **2.1 Research Object**

The object of the research is block paving prototype that uses thermoplastic waste. It is performed in production process laboratory, Mechanical Engineering Department, Universitas Islam Indonesia. The object was measured as 200 mm x 100 mm x 60 mm, press mold technique is applied to construct product.

### **2.2 Type and Source of Data**

Primary data is field research data that obtained from previous activities. Primary data uses as respond variable is compressive strength of block paving of thermoplastic waste, while the secondary data is derived indirectly from references, research literatures that related to Taguchi, researches on product quality of chicken feather composite, journals, magazines and other potential data that support recent research.

### **2.3 Tools and Materials**

Materials that applied to support the research are described as follows:

1. Office tools, to record all stages of research literally
2. Digital camera, for taking the pictures and recording the working process
3. Pressing tools UTM with capacity of 100 ton, that is used to press the mould
4. Plastic crusher with electrical motor HP, that is used to mash the plastic
5. Block paving mould with dimension of 20 cm x 10 cm x 6 cm, that is used to shape the block paving
6. Waterpass, that is used to measure the surface flatness balance of block paving
7. Stirred tools, shovel and hoe, that are used to stir up all materials
8. Bucket and basin with 50 ltr capacity that are used as container for mixed materials

9. Rectangle rasp and half round rasp that are used to soften the surface
10. Big hammer, that is used to unleash the mould
11. Water container with dimension of 1 m x 1m x 0,5 m, that is used to examine the absorption level
12. Vernier calliper, that is used to measure the dimension of block paving

Materials that applied in this research are:

1. Plastic waste, that is used as one of the composition of block paving
2. Portland cement, that is used as the mixture reinforcement
3. Sand, that is used as fine aggregate of block paving
4. Water, that is used as homogenous blender

## **2.4 Method of Data Collection**

The data collection in research defines as the efforts to accumulate facts and information intensively that followed by data analysis and test. Study literature is data collection that conducted by searching information from references as theory background, writing systematic and framework. They are derived from previous literatures and reports to support recent research.

## **2.5 Design of Experiment**

Design of experiment defines as provision of necessary information to perform experiment. The stages are explained as follows:

1. The selection of product quality
2. Identification and selection of influenced factors toward quality characteristics
3. Determination of controlled factors and noise factor toward factor level
4. Selection of orthogonal matrices for control factor (Inner Array) and uncontrollable factor (Outer Array)
5. Determination of combination matrices (Product Array)

## **2.6 Implementation of Experiment**

This stage describes the level of experiments result collection that is resumed from parameter design. The experiments implementation is executed under following steps:

1. Preparation, it is designated to prepare the tools, materials, pressing tools, mould and work environment
2. Block paving manufacturing, by combining cement, water, sand and heated plastic waste, to be poured to the mould and pressed using hydraulic press

3. Block paving quality control, it is designated to enhance the quality of block paving, started from surface softening to identify possible crack.
4. Compressive strength test, it is conducted to calculate the block paving compressive strength. The result will be used as preliminary data for data processing using Taguchi method

## 2.7 Analysis of Experiment

On the stage of data processing, analysis of the result is conducted statistically. Analysis procedure can be explained as follows:

1. Data Normality Test, it is conducted to find out whether the observation data normally distributed or not. Chi-square calculation is formulated, as follows:

$$X^2 = \sum_k^{i-1} \left( \frac{O_i - E_i}{E_i} \right) \quad (1)$$

2. Homogeneity of Variance Test, this test is conducted to analyze the homogeneity of k (k2) of population variance that normally distributed by using Bartlett test.

$$X^2_{hitung} = (In 10) \{B - \Sigma(n_i - 1) \log s_1^2\} \quad (2)$$

$$S_i^2 = \frac{1}{n-1} \left[ \sum_t^{i-1} y_1^2 - \left( \sum_t^{i-1} (y_i)^2 / n \right) \right] \quad (3)$$

$$B = (\log s^2) \Sigma(n_i - 1) \quad (4)$$

$$s^2 = \frac{\Sigma(n_i - 1) S_i^2}{\Sigma(n_i - 1)} \quad (5)$$

3. Signal to Noise Ratio (SNR) the experiment result and each factors effect, S/N ratio is explained as logarithm of quadratic loss function that used to evaluate products quality. S/N ratio is applied to figure out which level factor effects the result of experiment. S/N ratio consists of several type of quality characteristics, as follows:

- (a) Smaller the Better (STB)

Characteristic of quality states that, the smaller value, the better quality. S/N value for this characteristic is formulated as follows:

$$S/N_{STB} = -10 \log \left[ \frac{1}{n} \sum_n^{i=n} Y_i^2 \right] \quad (6)$$

## (b) Larger-the-Better

Characteristic of quality states that the bigger the value, the better quality. S/N value for this characteristic is formulated as follows:

$$S/N_{STB} = -10 \log \left[ \frac{1}{n} \sum_{i=1}^n \frac{1}{Y_i^2} \right] \quad (7)$$

## (c) Nominal-the-Better

It is defined as characteristic of quality with determined nominal. If the value reaches closer to the determined nominal, the quality will consider as better. S/N value for this characteristic is formulated as follows:

$$S/N_{STB} = -10 \log \left[ \frac{\mu}{\sigma} \right] \quad (8)$$

$$\sigma = \frac{\sum (y_i - \bar{y})^2}{n - 1} \quad (9)$$

### 3 RESULTS AND DISCUSSION

#### 3.1 Identification and Selection of Factor

Factors that involve in this experiments are explained as follows:

1. Type of cements that used are regular Portland and mixed Portland, the levels that used are mixed level and regular level, it applied to recognize the characteristic of Portland cement on block paving prototype
2. Drying durations are 30 days level and 35 days level. If it is applied less than 30 days, the mixture will experience uneven dryness while 35 days level will resume the opposite result, which is the complete dryness
3. 0,5 lt and 0,6 lt water level will be used. If the water level sets less than 0,5 Lt, it will experience fragile condition, while, more than 0,6 Lt will provide soft state material
4. 0,5 kg and 0,6 kg of cement will be employed. If it is less than 0,5 kg, the material compound will not blend perfectly, on the other hand, if it is more than 0,6 kg, the materials blend will vulnerable.
5. 1,5 kg and 1,6 kg coarse aggregate will be utilized, if it is less than 1,5 kg, the geometric size of block paving will be small. While, if it is more than 1,6 kg, the size will be grown bigger
6. 1 kg and 1,1 kg fine aggregate will be employed, if it is less than 1 kg, the geometric size of block paving will be small. While, if it is more than 1,1 kg, the size will be grown bigger
7. 300 gr and 600 gr plastic waste will be employed, if it is used less than 300 gr, the effect of waste utilization will be small, while, if it is more than 600 gr, the usage of waste is excessive,

Table 1: Controlling Factors

No	Material	Level 1	Level 2
A	Type of Cement	Regular Portland	Mixed Portland
B	Drying Duration	30 days	35 days
C	Water	0,5 Lt	0,6 Lt
D	Cement	0,5kg	0,6kg
E	Coarse Aggregate	1,5 kg	1,6 kg
F	Fine Aggregate	1 kg	1,1 kg
G	Plastic Waste	300gr	600gr

Table 2: Examples of writing table

Trial	1	2	3	4	5	6	7	Y1	Y2	Y3	Y4
1	1	1	1	1	1	1	1	13,5	14	12,7	13,9
2	1	1	1	2	2	2	2	14	12,5	12,4	12,7
3	1	2	2	1	1	2	2	13,2	13,2	13,8	12,9
4	1	2	2	2	2	1	1	13,2	13,5	14	13,8
5	2	1	2	1	2	1	2	12,9	11,9	13,9	11,8
6	2	1	2	2	1	2	1	12,8	12,1	13,6	11,7
7	2	2	1	1	2	2	1	14,1	14,6	12,8	13,2
8	2	2	1	2	1	1	2	11,8	12,4	13,9	12,6

### 3.2 Implementation of Experiment

It holds to discover compressive strength using L8 for inner array. The result data of experiment is shown by below table:

### 3.3 Data Processing

1. Normality Test, the result of this test by using Kolmogorov-Smirnov test shows that data fit with normal distribution with  $p = 0,2515$  ( $p < 0,05$ )
2. Homogeneity Test, states that group data possesses the same variance that indicates by  $p$  equal to 1,365 on the significance level of 0,05
3. Signal to Noise Ratio (SNR) to experiments result and effect on each factor shows that the best formulation is A2,B2,C1,D2,E1,F2,G1 under following composition; mixed Portland cement, 35 days drying duration, 0,5 lt water, 0,6 kg coarse aggregate, 1,1 kg fine aggregate and 300 gr plastic waste

## 4 CONCLUSION

Based on data analysis, can be concluded that normality test  $p = 0,2515$  ( $p < 0,05$ ) has normal characteristics, homogeneity test with  $p$  equal to 1, 365 on significance level of 0,05 indicates the homogenous characteristics. Combination of optimum factors based on analysis of



Signal to Noise Ratio and effect on each factor for compressive strength is A2,B2,C1,D2,E1,F2,G1 under following composition; mixed Portland cement, 35 days drying duration, 0,5 lt water, 0,6 kg coarse aggregate, 1,1 kg fine aggregate and 300 gr plastic waste.

## References

- Assauri, S., (1985), Manajemen Produksi dan Operasi, Lembaga Pemerintah, Jakarta.
- Badan Lingkungan Hidup Yogyakarta, (2012). Laporan Standar Pelayanan Minimal Bidang Lingkungan Hidup Daerah Istimewa Yogyakarta. Dibaca Tanggal 27 Februari 2014. *Terse-dia di [www. blhdiy.go.id](http://www.blhdiy.go.id)*
- Badan Pusat Statistik (2012). Statistik ternak unggas, dilihat 23 Desember 2013, terse-dia di: [http://yogyakarta.bps.go.id/flipbook/2013/Statistik%20Daerah%20Istimewa%20Yogy akar a%202013/HTML/files/assets/basic-html/page49.html](http://yogyakarta.bps.go.id/flipbook/2013/Statistik%20Daerah%20Istimewa%20Yogyakar a%202013/HTML/files/assets/basic-html/page49.html)
- Belavendram, N. (1995). *Quality By Design*. Prentice Hall, Internasional.
- Gasperz, Vincent., (2001). *total quality management*. Gramedia Pustaka Utama. Jakarta.
- Maheri, I, A. 2012. Studi Perbandingan Pasir, Ijuk dan Limbah Plastik Sebagai Drainase Ver-tikal. *Skripsi. Fakultas Teknik. Universitas Atma Jaya . Yogyakarta.*
- Montgomery. (1998). *Pengantar Pengendalian Kualitas*. UGM Press. Yogyakarta.
- Peace, G. S. (1993). *Taguchi Methods* . Addison - Wesley Publishing Company.
- Pratikto, 2010. Beton Ringan Ber-Agregat Limbah Botol Plastik Jenis PET (poly ethyleneterephthalate). *Prosiding Seminar Nasional Teknik Sipil*. Politeknik Negeri Jakarta.
- Putra, Y, H, S,. Indah Yulian dan Yayuk Sri Rahayu. tt. *Pendampingan Kemitraan Pen-gelolaan Limbah Botol Plastik Menjadi Produk Bernilai Ekonomis Pada Masyarakat Desa Girimoyo Karangploso Malang*. Fakultas Ekonomi. UIN Maulana Malik Ibrahim. Malang.
- Rismayasari, Y., Utari, Usman Santosa (2012). Pembuatan Beton dengan Campuran Limbah Plastik dan Karakterisasinya. *Indonesian Journal of Applied Physics*. Vol.2, No.1, Hal 21-31.
- Ross, P.J.(1998). *Taguchi Techniques For Quality Engineering*. McGraw-Hill, Inc., New York.
- Sari, D,M. dan Dadang Setiyawan., (2011). Peluang Bisnis Pemanfaatan Limbah Botol Plastik Menjadi Aneka Soevenir Hajatan. *Seminar Hasil Penelitian Dan Pengabdian Masyarakat*. Universitas Bantara Sukoharjo.
- Sebayang, S., I Wayan Diana dan Alexander Purba. (2011). Perbandingan Mutu Paving block Produksi Manual Dengan Produksi Masinal. *Jurnal Rekayasa* Vol. 15 No. 2, Agustus 2011
- Soebandono, B., Asat Pujianto dan Dinar Kurniawan. (2013). Perilaku Kuat Tekan dan Kuat Tarik Beton Campuran Limbah Plastik HDPE. *Jurnal Ilmiah Semesta Teknika*. Vol. 16, No. 1, Hal 76-82, Mei 2013

- Standar Nasional Indonesia. SNI 03-0691-1996. *Bata Beton (paving block)*. Badan Standar Nasional Indonesia.
- Standar Nasional Indonesia. SNI 19-2454-2002. *Proses Daur Ulang Sampah*. Badan Standar Nasional Indonesia.
- Standar Nasional Indonesia. SNI ISO 5328:2013. *Paving Blok Kayu Solid-Paving Blok Kayu Daun Jarum- Persyaratan mutu*. Badan Standar Nasional Indonesia.
- Sudjana. (1991). *Desain dan Analisis Eksperimen*. Penerbit Tarsito : Bandung.
- Surono, U, B. (2013). Berbagai Metode Konversi Sampah Plastik Menjadi Bahan Bakar Minyak. *Jurnal Teknik*, Vol-3, No-1, hal 32-40
- Zubair, A. Haeruddin, (2012). Studi Potensi Daur Ulang Sampah di TPA Tamangapa Kota Makassar. *Prosiding Hasil Penelitian Fakultas Teknik*. Vol-6, Hal TS1-TS10, Desember 2012.